

# Studio Essentials 23.03

## User Guide

03 - 2023

# Contents

<b>1. Introduction.....</b>	<b>5</b>
1.1. About Studio.....	5
1.1.1. An overview of editions and their modules.....	6
1.2. Copyright Notice.....	6
1.2.1. Third party license information.....	8
1.3. Licenses.....	33
<b>2. Getting Started with Studio Essentials.....</b>	<b>35</b>
2.1. Tutorial: Folding a box.....	35
2.2. Tutorial: revolve a path and add labels.....	39
2.3. Tutorial: combining shapes & working with Scenes.....	42
2.3.1. Additional steps to create the complete display.....	46
2.4. eLearning.....	49
<b>3. Step 1: Getting the 3D shape.....</b>	<b>50</b>
3.1. About Structural Design files and Printable Parts.....	50
3.1.1. The Studio Toolkit Application.....	51
3.2. Create a 3D Sheet.....	70
3.3. Create a box.....	71
3.3.1. Creating a Basic Box.....	71
3.3.2. Create a box based on die lines.....	75
3.3.3. Check the die and solve inaccuracies.....	80
3.3.4. Fold ArtiosCAD file.....	85
3.3.5. Tips & Tricks: create a cutout window in a box.....	85
3.4. Create a label.....	88
3.4.1. Front, Back and Wrap Around Labels.....	89
3.4.2. Creating a Freeform Label.....	93
3.4.3. Creating a revolved shape with labels.....	95
3.4.4. Creating a label from Curves.....	107
3.5. Browse Shapes.....	109
<b>4. Step 2: Applying and adjusting artwork.....</b>	<b>111</b>
4.1. The Studio Window.....	111
4.1.1. Refreshing.....	112
4.1.2. Designer, Visualizer and Ray Tracing quality.....	113
4.1.3. Changing the Document Orientation.....	113
4.1.4. Changing the view in the 3D preview.....	114
4.1.5. Full Screen Mode.....	114
4.1.6. The Studio Window options panel.....	115
4.2. Working with Parts and Panels.....	121

4.2.1. Selecting Parts and Panels.....	121
4.2.2. About Hidden Panels.....	123
4.2.3. Zooming in on Panels in the document window.....	123
4.2.4. Turn Box.....	124
4.2.5. Bring Panel Forward and Send Panel Backward.....	125
4.2.6. Creating Copies with the Distribute command.....	125
4.3. 3D Guides.....	138
4.3.1. Creating and Editing 3D Guides.....	139
4.3.2. Numeric Positioning of 3D Guides.....	141
4.4. Conical Warp.....	141
4.4.1. To apply conical warping.....	142
4.4.2. To reverse the conical warping.....	142
<b>5. Step 3: Presenting.....</b>	<b>143</b>
5.1. Visualizer Quality.....	143
5.1.1. Refreshing.....	144
5.1.2. Inks ignored in the 3D view.....	144
5.2. Ray Tracing Quality.....	145
5.3. Scene Settings.....	148
5.3.1. Environment.....	148
5.3.2. Floor Effects.....	149
5.3.3. View.....	149
5.3.4. Scene Presets.....	150
5.4. Scenes and Multiple Documents.....	151
5.4.1. Alternative scenes.....	151
5.4.2. Back side and Double-sided Artwork.....	153
5.4.3. Collada files or ACD files with Multiple Printable Parts.....	154
5.4.4. Multi-part structures from ArtiosCAD: ACD or Collada files.....	157
5.4.5. Navigating between the different Illustrator documents.....	159
5.4.6. Different graphics on shapes of the same size.....	160
5.5. Finishing Operations.....	162
5.5.1. Finishing Operations and swatches.....	162
5.5.2. The Finishing Operations palette.....	163
5.5.3. Set the Substrate Material.....	164
5.5.4. Add a new Finishing Operation.....	165
5.5.5. Finishing Profiles.....	171
5.6. Tips&Tricks: Using a Diecut operation.....	173
5.7. Tips & Tricks: Clear substrates and White Underprint.....	173
<b>6. Step 4: Share.....</b>	<b>175</b>
6.1. Export Image.....	175
6.1.1. Export Ray Tracing Quality Image.....	177
6.2. Export Image Sequence.....	178
6.2.1. Integrate an Image Sequence in an HTML5 web page.....	179

- 6.3. Export Collada File..... 181
- 6.4. Export KeyShot..... 182
- 6.5. Export a 3D PDF or U3D File..... 183
- 6.6. Export a Binary glTF..... 185
- 6.7. Studio Viewers..... 188
  - 6.7.1. Studio Viewer for Mac OS and Windows..... 188
  - 6.7.2. Studio Viewer for Mobile Devices..... 188
- 7. FAQ..... 191**
  - 7.1. Using Studio Designer and WebCenter Connector..... 191
  - 7.2. Using Studio Designer and Esko Cloud Connector..... 191
    - 7.2.1. Render Packshots on Esko Cloud..... 192
  - 7.3. I don't have Studio Essentials - where is my documentation ?..... 193
  - 7.4. Scripting..... 194



# 1. Introduction

---

## 1.1. About Studio

---

Studio is a unique set of tools for 3D packaging design made specifically for packaging artwork professionals.

Working in 3D for packaging typically consists of 4 steps: first you create a shape or "structure". Next you apply artwork to that shape. Then you set up the 3D representation. And finally you share the result as an image, a dynamic 3D representation, etc.

To achieve this, Studio has different components. It takes you through different software applications, such as Adobe Illustrator and the Studio Toolkit.



### Step 1: Get the 3D shape

The first step is to prepare a 3D packaging shape, with a matching 2D key line template. See [Step 1: Getting the 3D shape](#) on page 50

- You can receive a 3D shape of a box created in **ArtiosCAD** using 3D Modeling or 3D Drafting
- In **Studio** in Adobe Illustrator
  - you can clean up die-drawings of boxes and fold them into a 3D shape.
  - you can create a basic box.
  - you can create round objects with one or more labels.
- In the **Studio Toolkit**
  - you can draw labels on existing shapes.
  - you can create 3D models of flexible packaging.\*
  - you can create a heat shrink sleeve around one or more shapes, and simulate the distortion.\*

### Step 2: Apply Artwork

The second step is to make sure the production artwork fits to the structure. See [Step 2: Applying and adjusting artwork](#) on page 111

- In Adobe Illustrator, ArtPro or PackEdge, you can use the **Studio** window to get a preview of the 3D object with its artwork, check every detail, and fix specific issues.
- Using the Studio tools in Adobe Illustrator, you can apply a **Conical Warp** for labels on a round shape.
- Using the Studio tools in Adobe Illustrator, you can apply **Predistortion** for artwork on Shrink Sleeves.\*

**Step 3: Presenting**

The third step is to set up the presentation of your 3D model. See [Step 3: Presenting](#) on page 143

- In the **Studio** panel, you can combine multiple documents in multiple scenes.
- With the **Finishing operations** you can simulate print substrates and a wide range of print and finishing effects.

**Step 4: Share**

The final step is to share your 3D design. See [Step 4: Share](#) on page 175

You can share your 3D design using the Studio Viewer or Webcenter, or use your 3D design in Store Visualizer.

You can export your 3D designs to share realistic virtual packaging mock-ups as static images or interactive 3D.



**Note:** Items marked with an asterisk (\*) are not available in Studio Essentials, only in Studio Advanced.

**1.1.1. An overview of editions and their modules**

**Studio** is available in two editions: **Studio Essentials** and **Studio Advanced**. However, Studio is also still offered as in earlier versions, as 6 separate modules. The table below shows the relation between the editions and the modules.

Module	Studio Essentials	Studio Advanced
Studio Designer	✓	✓
Studio Toolkit for Boxes	✓	✓
Studio Toolkit for Labels	✓	✓
Studio Toolkit for Flexibles		✓
Studio Toolkit for Shrink Sleeves		✓
Studio Visualizer for Adobe Illustrator	✓	✓

This user manual is about Studio Essentials. If you have some but not all of its modules, some of the functionality described in this manual will not be available to you. See also: [I don't have Studio Essentials - where is my documentation ?](#) on page 193

**1.2. Copyright Notice**

© Copyright 2023 Esko Software BV, Gent, Belgium

All rights reserved. This material, information and instructions for use contained herein are the property of Esko Software BV. The material, information and instructions are provided on an AS IS basis without warranty of any kind. There are no warranties granted or extended by this document. Furthermore Esko Software BV does not warrant, guarantee or make any representations regarding

the use, or the results of the use of the software or the information contained herein. Esko Software BV shall not be liable for any direct, indirect, consequential or incidental damages arising out of the use or inability to use the software or the information contained herein.

The information contained herein is subject to change without notice. Revisions may be issued from time to time to advise of such changes and/or additions.

No part of this document may be reproduced, stored in a data base or retrieval system, or published, in any form or in any way, electronically, mechanically, by print, photoprint, microfilm or any other means without prior written permission from Esko Software BV.

This document supersedes all previous dated versions.

PANTONE<sup>®</sup> Colors displayed in the software application or in the user documentation may not match PANTONE-identified standards. Consult current PANTONE Color Publications for accurate color. PANTONE<sup>®</sup> and other Pantone trademarks are the property of Pantone LLC. © Pantone LLC, 2015

Pantone is the copyright owner of color data and/or software which are licensed to Esko to distribute for use only in combination with Studio Visualizer. PANTONE Color Data and/or Software shall not be copied onto another disk or into memory unless as part of the execution of Studio Visualizer.

This software is based in part on the work of the Independent JPEG Group.

Portions of this software are copyright © 1996-2002 The FreeType Project ([www.freetype.org](http://www.freetype.org)). All rights reserved.

Portions of this software are copyright 2006 Feeling Software, copyright 2005-2006 Autodesk Media Entertainment.

Portions of this software are copyright ©1998-2003 Daniel Veillard. All rights reserved.

Portions of this software are copyright ©1999-2006 The Botan Project. All rights reserved.

Part of the software embedded in this product is gSOAP software. Portions created by gSOAP are Copyright ©2001-2004 Robert A. van Engelen, Genivia inc. All rights reserved.

Portions of this software are copyright ©1998-2008 The OpenSSL Project and ©1995-1998 Eric Young ([ey@cryptsoft.com](mailto:ey@cryptsoft.com)). All rights reserved.

This product includes software developed by the Apache Software Foundation (<http://www.apache.org/>).

Adobe, the Adobe logo, Acrobat, the Acrobat logo, Adobe Creative Suite, Illustrator, InDesign, PDF, Photoshop, PostScript, XMP and the Powered by XMP logo are either registered trademarks or trademarks of Adobe Systems Incorporated in the United States and/or other countries.

Microsoft and the Microsoft logo are registered trademarks of Microsoft Corporation in the United States and other countries.

SolidWorks is a registered trademark of SolidWorks Corporation.

Portions of this software are owned by Spatial Corp. 1986 2003. All Rights Reserved.

JDF and the JDF logo are trademarks of the CIP4 Organisation. Copyright 2001 The International Cooperation for the Integration of Processes in Prepress, Press and Postpress (CIP4). All rights reserved.

The Esko software contains the RSA Data Security, Inc. MD5 Message-Digest Algorithm.

Java and all Java-based trademarks and logos are trademarks or registered trademarks of Sun Microsystems in the U.S. and other countries.

Part of this software uses technology by Best Color Technology (EFI). EFI and Bestcolor are registered trademarks of Electronics For Imaging GmbH in the U.S. Patent and Trademark Office.

Contains PowerNest library Copyrighted and Licensed by Alma, 2005 – 2007.

Part of this software uses technology by GlobalVision. ArtProof and ScanProof are registered trademarks of GlobalVision Inc.

Part of this software uses technology by Qoppa Software. Copyright © 2002-Present. All Rights Reserved.

All other product names are trademarks or registered trademarks of their respective owners.

Correspondence regarding this publication should be forwarded to:

Esko Software BV  
 Raymonde de Larocheaan 13  
 B – 9051 Gent  
 info.eur@esko.com

### 1.2.1. Third party license information

This product includes assimp.

Open Asset Import Library (assimp)

Copyright (c) 2006-2016, assimp team  
 All rights reserved.

Redistribution and use of this software in source and binary forms, with or without modification, are permitted provided that the following conditions are met:

- \* Redistributions of source code must retain the above copyright notice, this list of conditions and the following disclaimer.
- \* Redistributions in binary form must reproduce the above copyright notice, this list of conditions and the following disclaimer in the documentation and/or other materials provided with the distribution.
- \* Neither the name of the assimp team, nor the names of its contributors may be used to endorse or promote products derived from this software without specific prior written permission of the assimp team.

THIS SOFTWARE IS PROVIDED BY THE COPYRIGHT HOLDERS AND CONTRIBUTORS "AS IS" AND ANY EXPRESS OR IMPLIED WARRANTIES, INCLUDING, BUT NOT LIMITED TO, THE IMPLIED WARRANTIES OF MERCHANTABILITY AND FITNESS FOR A PARTICULAR PURPOSE ARE DISCLAIMED. IN NO EVENT SHALL THE COPYRIGHT OWNER OR CONTRIBUTORS BE LIABLE FOR ANY DIRECT, INDIRECT, INCIDENTAL, SPECIAL, EXEMPLARY, OR CONSEQUENTIAL DAMAGES (INCLUDING, BUT NOT LIMITED TO, PROCUREMENT OF SUBSTITUTE GOODS OR SERVICES; LOSS OF USE, DATA, OR PROFITS; OR BUSINESS INTERRUPTION) HOWEVER CAUSED AND ON ANY THEORY OF LIABILITY, WHETHER IN CONTRACT, STRICT LIABILITY, OR TORT (INCLUDING NEGLIGENCE OR OTHERWISE) ARISING IN ANY WAY OUT OF THE USE OF THIS SOFTWARE, EVEN IF ADVISED OF THE POSSIBILITY OF SUCH DAMAGE.

-----  
 This product includes Poly2Tri.

All rights reserved.  
 Redistribution and use in source and binary forms, with or without modification, are permitted provided that the following conditions are met:

- \* Redistributions of source code must retain the above copyright notice,

this list of conditions and the following disclaimer.  
 \* Redistributions in binary form must reproduce the above copyright notice, this list of conditions and the following disclaimer in the documentation and/or other materials provided with the distribution.  
 \* Neither the name of Poly2Tri nor the names of its contributors may be used to endorse or promote products derived from this software without specific prior written permission.

THIS SOFTWARE IS PROVIDED BY THE COPYRIGHT HOLDERS AND CONTRIBUTORS "AS IS" AND ANY EXPRESS OR IMPLIED WARRANTIES, INCLUDING, BUT NOT LIMITED TO, THE IMPLIED WARRANTIES OF MERCHANTABILITY AND FITNESS FOR A PARTICULAR PURPOSE ARE DISCLAIMED. IN NO EVENT SHALL THE COPYRIGHT OWNER OR CONTRIBUTORS BE LIABLE FOR ANY DIRECT, INDIRECT, INCIDENTAL, SPECIAL, EXEMPLARY, OR CONSEQUENTIAL DAMAGES (INCLUDING, BUT NOT LIMITED TO, PROCUREMENT OF SUBSTITUTE GOODS OR SERVICES; LOSS OF USE, DATA, OR PROFITS; OR BUSINESS INTERRUPTION) HOWEVER CAUSED AND ON ANY THEORY OF LIABILITY, WHETHER IN CONTRACT, STRICT LIABILITY, OR TORT (INCLUDING NEGLIGENCE OR OTHERWISE) ARISING IN ANY WAY OUT OF THE USE OF THIS SOFTWARE, EVEN IF ADVISED OF THE POSSIBILITY OF SUCH DAMAGE.

-----  
 This product includes patented technology.

This product and use of this product is under license from Markzware under U.S. Patent No. 5,963,641.

-----  
 This product includes pugixml.

MIT License

Copyright (c) 2006-2022 Arseny Kapoulkine

Permission is hereby granted, free of charge, to any person obtaining a copy of this software and associated documentation files (the "Software"), to deal in the Software without restriction, including without limitation the rights to use, copy, modify, merge, publish, distribute, sublicense, and/or sell copies of the Software, and to permit persons to whom the Software is furnished to do so, subject to the following conditions:

The above copyright notice and this permission notice shall be included in all copies or substantial portions of the Software.

THE SOFTWARE IS PROVIDED "AS IS", WITHOUT WARRANTY OF ANY KIND, EXPRESS OR IMPLIED, INCLUDING BUT NOT LIMITED TO THE WARRANTIES OF MERCHANTABILITY, FITNESS FOR A PARTICULAR PURPOSE AND NONINFRINGEMENT. IN NO EVENT SHALL THE AUTHORS OR COPYRIGHT HOLDERS BE LIABLE FOR ANY CLAIM, DAMAGES OR OTHER LIABILITY, WHETHER IN AN ACTION OF CONTRACT, TORT OR OTHERWISE, ARISING FROM, OUT OF OR IN CONNECTION WITH THE SOFTWARE OR THE USE OR OTHER DEALINGS IN THE SOFTWARE.

-----  
 This product includes curl.

COPYRIGHT AND PERMISSION NOTICE

Copyright (c) 1996 - 2020, Daniel Stenberg, <daniel@haxx.se>, and many contributors, see the THANKS file.

All rights reserved.

Permission to use, copy, modify, and distribute this software for any purpose with or without fee is hereby granted, provided that the above copyright notice and this permission notice appear in all copies.

THE SOFTWARE IS PROVIDED "AS IS", WITHOUT WARRANTY OF ANY KIND, EXPRESS OR IMPLIED, INCLUDING BUT NOT LIMITED TO THE WARRANTIES OF MERCHANTABILITY, FITNESS FOR A PARTICULAR PURPOSE AND NONINFRINGEMENT OF THIRD PARTY RIGHTS. IN NO EVENT SHALL THE AUTHORS OR COPYRIGHT HOLDERS BE LIABLE FOR ANY CLAIM, DAMAGES OR OTHER LIABILITY, WHETHER IN AN ACTION OF CONTRACT, TORT OR

OTHERWISE, ARISING FROM, OUT OF OR IN CONNECTION WITH THE SOFTWARE OR THE USE OR OTHER DEALINGS IN THE SOFTWARE.

Except as contained in this notice, the name of a copyright holder shall not be used in advertising or otherwise to promote the sale, use or other dealings in this Software without prior written authorization of the copyright holder.

-----  
 This product includes Little CMS.

Little CMS  
 Copyright (c) 1998-2020 Marti Maria Saguer

Permission is hereby granted, free of charge, to any person obtaining a copy of this software and associated documentation files (the "Software"), to deal in the Software without restriction, including without limitation the rights to use, copy, modify, merge, publish, distribute, sublicense, and/or sell copies of the Software, and to permit persons to whom the Software is furnished to do so, subject to the following conditions:

The above copyright notice and this permission notice shall be included in all copies or substantial portions of the Software.

THE SOFTWARE IS PROVIDED "AS IS", WITHOUT WARRANTY OF ANY KIND, EXPRESS OR IMPLIED, INCLUDING BUT NOT LIMITED TO THE WARRANTIES OF MERCHANTABILITY, FITNESS FOR A PARTICULAR PURPOSE AND NONINFRINGEMENT. IN NO EVENT SHALL THE AUTHORS OR COPYRIGHT HOLDERS BE LIABLE FOR ANY CLAIM, DAMAGES OR OTHER LIABILITY, WHETHER IN AN ACTION OF CONTRACT, TORT OR OTHERWISE, ARISING FROM, OUT OF OR IN CONNECTION WITH THE SOFTWARE OR THE USE OR OTHER DEALINGS IN THE SOFTWARE.

-----  
 This product includes lzw-ab.

Copyright (c) David Bryant  
 All rights reserved.

Redistribution and use in source and binary forms, with or without modification, are permitted provided that the following conditions are met:

- \* Redistributions of source code must retain the above copyright notice, this list of conditions and the following disclaimer.
- \* Redistributions in binary form must reproduce the above copyright notice, this list of conditions and the following disclaimer in the documentation and/or other materials provided with the distribution.
- \* Neither the name of Conifer Software nor the names of its contributors may be used to endorse or promote products derived from this software without specific prior written permission.

THIS SOFTWARE IS PROVIDED BY THE COPYRIGHT HOLDERS AND CONTRIBUTORS "AS IS" AND ANY EXPRESS OR IMPLIED WARRANTIES, INCLUDING, BUT NOT LIMITED TO, THE IMPLIED WARRANTIES OF MERCHANTABILITY AND FITNESS FOR A PARTICULAR PURPOSE ARE DISCLAIMED. IN NO EVENT SHALL THE REGENTS OR CONTRIBUTORS BE LIABLE FOR ANY DIRECT, INDIRECT, INCIDENTAL, SPECIAL, EXEMPLARY, OR CONSEQUENTIAL DAMAGES (INCLUDING, BUT NOT LIMITED TO, PROCUREMENT OF SUBSTITUTE GOODS OR SERVICES; LOSS OF USE, DATA, OR PROFITS; OR BUSINESS INTERRUPTION) HOWEVER CAUSED AND ON ANY THEORY OF LIABILITY, WHETHER IN CONTRACT, STRICT LIABILITY, OR TORT (INCLUDING NEGLIGENCE OR OTHERWISE) ARISING IN ANY WAY OUT OF THE USE OF THIS SOFTWARE, EVEN IF ADVISED OF THE POSSIBILITY OF SUCH DAMAGE.

-----  
 This product includes OpenJPEG.

The copyright in this software is being made available under the 2-clauses BSD License, included below. This software may be subject to other third party and contributor rights, including patent rights, and no such rights are granted under this license.

Copyright (c) 2002-2014, Universite catholique de Louvain (UCL), Belgium  
 Copyright (c) 2002-2014, Professor Benoit Macq  
 Copyright (c) 2003-2014, Antonin Descampe  
 Copyright (c) 2003-2009, Francois-Olivier Devaux  
 Copyright (c) 2005, Herve Drolon, FreeImage Team

Copyright (c) 2002-2003, Yannick Verschueren  
 Copyright (c) 2001-2003, David Janssens  
 Copyright (c) 2011-2012, Centre National d'Etudes Spatiales (CNES), France  
 Copyright (c) 2012, CS Systemes d'Information, France

All rights reserved.

Redistribution and use in source and binary forms, with or without modification, are permitted provided that the following conditions are met:

1. Redistributions of source code must retain the above copyright notice, this list of conditions and the following disclaimer.
2. Redistributions in binary form must reproduce the above copyright notice, this list of conditions and the following disclaimer in the documentation and/or other materials provided with the distribution.

THIS SOFTWARE IS PROVIDED BY THE COPYRIGHT HOLDERS AND CONTRIBUTORS 'AS IS' AND ANY EXPRESS OR IMPLIED WARRANTIES, INCLUDING, BUT NOT LIMITED TO, THE IMPLIED WARRANTIES OF MERCHANTABILITY AND FITNESS FOR A PARTICULAR PURPOSE ARE DISCLAIMED. IN NO EVENT SHALL THE COPYRIGHT OWNER OR CONTRIBUTORS BE LIABLE FOR ANY DIRECT, INDIRECT, INCIDENTAL, SPECIAL, EXEMPLARY, OR CONSEQUENTIAL DAMAGES (INCLUDING, BUT NOT LIMITED TO, PROCUREMENT OF SUBSTITUTE GOODS OR SERVICES; LOSS OF USE, DATA, OR PROFITS; OR BUSINESS INTERRUPTION) HOWEVER CAUSED AND ON ANY THEORY OF LIABILITY, WHETHER IN CONTRACT, STRICT LIABILITY, OR TORT (INCLUDING NEGLIGENCE OR OTHERWISE) ARISING IN ANY WAY OUT OF THE USE OF THIS SOFTWARE, EVEN IF ADVISED OF THE POSSIBILITY OF SUCH DAMAGE.

-----  
 This product includes FreeType.

Portions of this software are copyright (C) 2014 The FreeType Project ([www.freetype.org](http://www.freetype.org)) licensed under the FreeType License. All rights reserved.

-----  
 This product includes QtCopyDialog.

Copyright (c) 2009 Nokia Corporation and/or its subsidiary(-ies). All rights reserved.

BECAUSE THE LIBRARY IS LICENSED FREE OF CHARGE, THERE IS NO WARRANTY FOR THE LIBRARY, TO THE EXTENT PERMITTED BY APPLICABLE LAW. EXCEPT WHEN OTHERWISE STATED IN WRITING THE COPYRIGHT HOLDERS AND/OR OTHER PARTIES PROVIDE THE LIBRARY "AS IS" WITHOUT WARRANTY OF ANY KIND, EITHER EXPRESSED OR IMPLIED, INCLUDING, BUT NOT LIMITED TO, THE IMPLIED WARRANTIES OF MERCHANTABILITY AND FITNESS FOR A PARTICULAR PURPOSE. THE ENTIRE RISK AS TO THE QUALITY AND PERFORMANCE OF THE LIBRARY IS WITH YOU. SHOULD THE LIBRARY PROVE DEFECTIVE, YOU ASSUME THE COST OF ALL NECESSARY SERVICING, REPAIR OR CORRECTION.

-----  
 This product includes QtMigration.

Copyright (C) 2013 Digia Plc and/or its subsidiary(-ies).

Redistribution and use in source and binary forms, with or without modification, are permitted provided that the following conditions are met:

- \* Redistributions of source code must retain the above copyright notice, this list of conditions and the following disclaimer.
- \* Redistributions in binary form must reproduce the above copyright notice, this list of conditions and the following disclaimer in the documentation and/or other materials provided with the distribution.
- \* Neither the name of Digia Plc and its Subsidiary(-ies) nor the names of its contributors may be used to endorse or promote products derived from this software without specific prior written permission.

THIS SOFTWARE IS PROVIDED BY THE COPYRIGHT HOLDERS AND CONTRIBUTORS "AS IS" AND ANY EXPRESS OR IMPLIED WARRANTIES, INCLUDING, BUT NOT LIMITED TO, THE IMPLIED WARRANTIES OF MERCHANTABILITY AND FITNESS FOR A PARTICULAR PURPOSE ARE DISCLAIMED. IN NO EVENT SHALL THE COPYRIGHT OWNER OR CONTRIBUTORS BE LIABLE FOR ANY DIRECT, INDIRECT, INCIDENTAL,

SPECIAL, EXEMPLARY, OR CONSEQUENTIAL DAMAGES (INCLUDING, BUT NOT LIMITED TO, PROCUREMENT OF SUBSTITUTE GOODS OR SERVICES; LOSS OF USE, DATA, OR PROFITS; OR BUSINESS INTERRUPTION) HOWEVER CAUSED AND ON ANY THEORY OF LIABILITY, WHETHER IN CONTRACT, STRICT LIABILITY, OR TORT (INCLUDING NEGLIGENCE OR OTHERWISE) ARISING IN ANY WAY OUT OF THE USE OF THIS SOFTWARE, EVEN IF ADVISED OF THE POSSIBILITY OF SUCH DAMAGE."

-----

This product includes QtService.

Copyright (C) 2010 Nokia Corporation and/or its subsidiary(-ies).

Redistribution and use in source and binary forms, with or without modification, are permitted provided that the following conditions are met:

- \* Redistributions of source code must retain the above copyright notice, this list of conditions and the following disclaimer.
- \* Redistributions in binary form must reproduce the above copyright notice, this list of conditions and the following disclaimer in the documentation and/or other materials provided with the distribution.
- \* Neither the name of Nokia Corporation and its Subsidiary(-ies) nor the names of its contributors may be used to endorse or promote products derived from this software without specific prior written permission.

THIS SOFTWARE IS PROVIDED BY THE COPYRIGHT HOLDERS AND CONTRIBUTORS "AS IS" AND ANY EXPRESS OR IMPLIED WARRANTIES, INCLUDING, BUT NOT LIMITED TO, THE IMPLIED WARRANTIES OF MERCHANTABILITY AND FITNESS FOR A PARTICULAR PURPOSE ARE DISCLAIMED. IN NO EVENT SHALL THE COPYRIGHT OWNER OR CONTRIBUTORS BE LIABLE FOR ANY DIRECT, INDIRECT, INCIDENTAL, SPECIAL, EXEMPLARY, OR CONSEQUENTIAL DAMAGES (INCLUDING, BUT NOT LIMITED TO, PROCUREMENT OF SUBSTITUTE GOODS OR SERVICES; LOSS OF USE, DATA, OR PROFITS; OR BUSINESS INTERRUPTION) HOWEVER CAUSED AND ON ANY THEORY OF LIABILITY, WHETHER IN CONTRACT, STRICT LIABILITY, OR TORT (INCLUDING NEGLIGENCE OR OTHERWISE) ARISING IN ANY WAY OUT OF THE USE OF THIS SOFTWARE, EVEN IF ADVISED OF THE POSSIBILITY OF SUCH DAMAGE.

-----

This product includes QtSingleApplication.

Copyright (C) 2010 Nokia Corporation and/or its subsidiary(-ies). All rights reserved.

Redistribution and use in source and binary forms, with or without modification, are permitted provided that the following conditions are met:

- \* Redistributions of source code must retain the above copyright notice, this list of conditions and the following disclaimer.
- \* Redistributions in binary form must reproduce the above copyright notice, this list of conditions and the following disclaimer in the documentation and/or other materials provided with the distribution.
- \* Neither the name of Nokia Corporation and its Subsidiary(-ies) nor the names of its contributors may be used to endorse or promote products derived from this software without specific prior written permission.

THIS SOFTWARE IS PROVIDED BY THE COPYRIGHT HOLDERS AND CONTRIBUTORS "AS IS" AND ANY EXPRESS OR IMPLIED WARRANTIES, INCLUDING, BUT NOT LIMITED TO, THE IMPLIED WARRANTIES OF MERCHANTABILITY AND FITNESS FOR A PARTICULAR PURPOSE ARE DISCLAIMED. IN NO EVENT SHALL THE COPYRIGHT OWNER OR CONTRIBUTORS BE LIABLE FOR ANY DIRECT, INDIRECT, INCIDENTAL, SPECIAL, EXEMPLARY, OR CONSEQUENTIAL DAMAGES (INCLUDING, BUT NOT LIMITED TO, PROCUREMENT OF SUBSTITUTE GOODS OR SERVICES; LOSS OF USE, DATA, OR PROFITS; OR BUSINESS INTERRUPTION) HOWEVER CAUSED AND ON ANY THEORY OF LIABILITY, WHETHER IN CONTRACT, STRICT LIABILITY, OR TORT (INCLUDING NEGLIGENCE OR OTHERWISE) ARISING IN ANY WAY OUT OF THE USE OF THIS SOFTWARE, EVEN IF ADVISED OF THE POSSIBILITY OF SUCH DAMAGE.

-----

This product includes QtSingleApplication.



Copyright (C) 2013 Digia Plc and/or its subsidiary(-ies).  
Contact: <http://www.qt-project.org/legal>

This file is part of the Qt Solutions component.

You may use this file under the terms of the BSD license as follows:

Redistribution and use in source and binary forms, with or without modification, are permitted provided that the following conditions are met:

- \* Redistributions of source code must retain the above copyright notice, this list of conditions and the following disclaimer.
- \* Redistributions in binary form must reproduce the above copyright notice, this list of conditions and the following disclaimer in the documentation and/or other materials provided with the distribution.
- \* Neither the name of Digia Plc and its Subsidiary(-ies) nor the names of its contributors may be used to endorse or promote products derived from this software without specific prior written permission.

THIS SOFTWARE IS PROVIDED BY THE COPYRIGHT HOLDERS AND CONTRIBUTORS "AS IS" AND ANY EXPRESS OR IMPLIED WARRANTIES, INCLUDING, BUT NOT LIMITED TO, THE IMPLIED WARRANTIES OF MERCHANTABILITY AND FITNESS FOR A PARTICULAR PURPOSE ARE DISCLAIMED. IN NO EVENT SHALL THE COPYRIGHT OWNER OR CONTRIBUTORS BE LIABLE FOR ANY DIRECT, INDIRECT, INCIDENTAL, SPECIAL, EXEMPLARY, OR CONSEQUENTIAL DAMAGES (INCLUDING, BUT NOT LIMITED TO, PROCUREMENT OF SUBSTITUTE GOODS OR SERVICES; LOSS OF USE, DATA, OR PROFITS; OR BUSINESS INTERRUPTION) HOWEVER CAUSED AND ON ANY THEORY OF LIABILITY, WHETHER IN CONTRACT, STRICT LIABILITY, OR TORT (INCLUDING NEGLIGENCE OR OTHERWISE) ARISING IN ANY WAY OUT OF THE USE OF THIS SOFTWARE, EVEN IF ADVISED OF THE POSSIBILITY OF SUCH DAMAGE.

-----  
This product includes range-v3.

University of Illinois/NCSA  
Open Source License

Copyright (c) 2003-2019 University of Illinois at Urbana-Champaign.  
All rights reserved.

Developed by:

LLVM Team

University of Illinois at Urbana-Champaign

<http://llvm.org>

Permission is hereby granted, free of charge, to any person obtaining a copy of this software and associated documentation files (the "Software"), to deal with the Software without restriction, including without limitation the rights to use, copy, modify, merge, publish, distribute, sublicense, and/or sell copies of the Software, and to permit persons to whom the Software is furnished to do so, subject to the following conditions:

- \* Redistributions of source code must retain the above copyright notice, this list of conditions and the following disclaimers.
- \* Redistributions in binary form must reproduce the above copyright notice, this list of conditions and the following disclaimers in the documentation and/or other materials provided with the distribution.
- \* Neither the names of the LLVM Team, University of Illinois at Urbana-Champaign, nor the names of its contributors may be used to endorse or promote products derived from this Software without specific prior written permission.

THE SOFTWARE IS PROVIDED "AS IS", WITHOUT WARRANTY OF ANY KIND, EXPRESS OR IMPLIED, INCLUDING BUT NOT LIMITED TO THE WARRANTIES OF MERCHANTABILITY, FITNESS FOR A PARTICULAR PURPOSE AND NONINFRINGEMENT. IN NO EVENT SHALL THE CONTRIBUTORS OR COPYRIGHT HOLDERS BE LIABLE FOR ANY CLAIM, DAMAGES OR OTHER LIABILITY, WHETHER IN AN ACTION OF CONTRACT, TORT OR OTHERWISE, ARISING FROM, OUT OF OR IN CONNECTION WITH THE SOFTWARE OR THE USE OR OTHER DEALINGS WITH THE

SOFTWARE.

-----  
 This product includes range-v3.

Copyright (c) 2009 Alexander Stepanov and Paul McJones

Permission to use, copy, modify, distribute and sell this software and its documentation for any purpose is hereby granted without fee, provided that the above copyright notice appear in all copies and that both that copyright notice and this permission notice appear in supporting documentation. The authors make no representations about the suitability of this software for any purpose. It is provided "as is" without express or implied warranty.

Algorithms from  
 Elements of Programming  
 by Alexander Stepanov and Paul McJones  
 Addison-Wesley Professional, 2009

-----  
 This product includes range-v3.

Copyright (c) 1994  
 Hewlett-Packard Company

Permission to use, copy, modify, distribute and sell this software and its documentation for any purpose is hereby granted without fee, provided that the above copyright notice appear in all copies and that both that copyright notice and this permission notice appear in supporting documentation. Hewlett-Packard Company makes no representations about the suitability of this software for any purpose. It is provided "as is" without express or implied warranty.

-----  
 This product includes range-v3.

Copyright (c) 1996  
 Silicon Graphics Computer Systems, Inc.

Permission to use, copy, modify, distribute and sell this software and its documentation for any purpose is hereby granted without fee, provided that the above copyright notice appear in all copies and that both that copyright notice and this permission notice appear in supporting documentation. Silicon Graphics makes no representations about the suitability of this software for any purpose. It is provided "as is" without express or implied warranty.

-----  
 This product includes QtSql.

Copyright (c) 2009 Nokia Corporation and/or its subsidiary(-ies).

BECAUSE THE LIBRARY IS LICENSED FREE OF CHARGE, THERE IS NO WARRANTY FOR THE LIBRARY, TO THE EXTENT PERMITTED BY APPLICABLE LAW. EXCEPT WHEN OTHERWISE STATED IN WRITING THE COPYRIGHT HOLDERS AND/OR OTHER PARTIES PROVIDE THE LIBRARY "AS IS" WITHOUT WARRANTY OF ANY KIND, EITHER EXPRESSED OR IMPLIED, INCLUDING, BUT NOT LIMITED TO, THE IMPLIED WARRANTIES OF MERCHANTABILITY AND FITNESS FOR A PARTICULAR PURPOSE. THE ENTIRE RISK AS TO THE QUALITY AND PERFORMANCE OF THE LIBRARY IS WITH YOU. SHOULD THE LIBRARY PROVE DEFECTIVE, YOU ASSUME THE COST OF ALL NECESSARY SERVICING, REPAIR OR CORRECTION.

-----  
 This product includes svgio.

Copyright Oleg Maximenko 2014.  
 Distributed under the Boost Software License, Version 1.0.

This product includes QtSvg.

The Qt Toolkit is Copyright (C) 2019 The Qt Company Ltd.

-----  
 This product includes ZXing C++ Library.

-----  
 NOTICES FOR TextCodec

-----  
 Part of this software uses code source from Qt under LGPL license.  
 Copyright (C) 2015 The Qt Company Ltd.

-----  
 NOTICES FOR ZXing

-----  
 Copyright 2016 ZXing authors.  
<https://github.com/zxing>

-----  
 This product includes LibTIFF.

Copyright (c) 1988-1997 Sam Leffler  
 Copyright (c) 1991-1997 Silicon Graphics, Inc.

Permission to use, copy, modify, distribute, and sell this software and its documentation for any purpose is hereby granted without fee, provided that (i) the above copyright notices and this permission notice appear in all copies of the software and related documentation, and (ii) the names of Sam Leffler and Silicon Graphics may not be used in any advertising or publicity relating to the software without the specific, prior written permission of Sam Leffler and Silicon Graphics.

THE SOFTWARE IS PROVIDED "AS-IS" AND WITHOUT WARRANTY OF ANY KIND, EXPRESS, IMPLIED OR OTHERWISE, INCLUDING WITHOUT LIMITATION, ANY WARRANTY OF MERCHANTABILITY OR FITNESS FOR A PARTICULAR PURPOSE.

IN NO EVENT SHALL SAM LEFFLER OR SILICON GRAPHICS BE LIABLE FOR ANY SPECIAL, INCIDENTAL, INDIRECT OR CONSEQUENTIAL DAMAGES OF ANY KIND, OR ANY DAMAGES WHATSOEVER RESULTING FROM LOSS OF USE, DATA OR PROFITS, WHETHER OR NOT ADVISED OF THE POSSIBILITY OF DAMAGE, AND ON ANY THEORY OF LIABILITY, ARISING OUT OF OR IN CONNECTION WITH THE USE OR PERFORMANCE OF THIS SOFTWARE.

-----  
 This product includes appleseed.  
 The MIT License (MIT)

Copyright (c) 2010-2013 Francois Beaune, Jupiter Jazz Limited  
 Copyright (c) 2014-2019 The appleseedhq Organization

Permission is hereby granted, free of charge, to any person obtaining a copy of this software and associated documentation files (the "Software"), to deal in the Software without restriction, including without limitation the rights to use, copy, modify, merge, publish, distribute, sublicense, and/or sell copies of the Software, and to permit persons to whom the Software is furnished to do so, subject to the following conditions:

The above copyright notice and this permission notice shall be included in all copies or substantial portions of the Software.

THE SOFTWARE IS PROVIDED "AS IS", WITHOUT WARRANTY OF ANY KIND, EXPRESS OR IMPLIED, INCLUDING BUT NOT LIMITED TO THE WARRANTIES OF MERCHANTABILITY, FITNESS FOR A PARTICULAR PURPOSE AND NONINFRINGEMENT. IN NO EVENT SHALL THE AUTHORS OR COPYRIGHT HOLDERS BE LIABLE FOR ANY CLAIM, DAMAGES OR OTHER LIABILITY, WHETHER IN AN ACTION OF CONTRACT, TORT OR OTHERWISE, ARISING FROM, OUT OF OR IN CONNECTION WITH THE SOFTWARE OR THE USE OR OTHER DEALINGS IN THE SOFTWARE.

-----  
 This product includes bcd.

```

Copyright (c) 2017 Malik Boughida and Tamy Boubekur. All rights reserved.

Redistribution and use in source and binary forms, with or without
modification, are permitted provided that the following conditions are met:

1. Redistributions of source code must retain the above copyright notice, this
list of conditions and the following disclaimer.

2. Redistributions in binary form must reproduce the above copyright notice,
this list of conditions and the following disclaimer in the documentation
and/or other materials provided with the distribution.

3. Neither the name of the copyright holder nor the names of its contributors
may be used to endorse or promote products derived from this software
without specific prior written permission.

THIS SOFTWARE IS PROVIDED BY THE COPYRIGHT HOLDERS AND CONTRIBUTORS "AS IS" AND
ANY EXPRESS OR IMPLIED WARRANTIES, INCLUDING, BUT NOT LIMITED TO, THE IMPLIED
WARRANTIES OF MERCHANTABILITY AND FITNESS FOR A PARTICULAR PURPOSE ARE
DISCLAIMED. IN NO EVENT SHALL THE COPYRIGHT HOLDER OR CONTRIBUTORS BE LIABLE
FOR ANY DIRECT, INDIRECT, INCIDENTAL, SPECIAL, EXEMPLARY, OR CONSEQUENTIAL
DAMAGES (INCLUDING, BUT NOT LIMITED TO, PROCUREMENT OF SUBSTITUTE GOODS OR
SERVICES; LOSS OF USE, DATA, OR PROFITS; OR BUSINESS INTERRUPTION) HOWEVER
CAUSED AND ON ANY THEORY OF LIABILITY, WHETHER IN CONTRACT, STRICT LIABILITY,
OR TORT (INCLUDING NEGLIGENCE OR OTHERWISE) ARISING IN ANY WAY OUT OF THE USE
OF THIS SOFTWARE, EVEN IF ADVISED OF THE POSSIBILITY OF SUCH DAMAGE.

You are under no obligation whatsoever to provide any bug fixes, patches, or
upgrades to the features, functionality or performance of the source code
("Enhancements") to anyone; however, if you choose to make your Enhancements
available either publicly, or directly to the authors of this software, without
imposing a separate written license agreement for such Enhancements, then you
hereby grant the following license: a non-exclusive, royalty-free perpetual
license to install, use, modify, prepare derivative works, incorporate into
other computer software, distribute, and sublicense such enhancements or
derivative works thereof, in binary and source code form.

-----

This product includes glad.

The MIT License (MIT)

Copyright (c) 2013-2018 David Herberth

Permission is hereby granted, free of charge, to any person obtaining a copy of
this software and associated documentation files (the "Software"), to deal in
the Software without restriction, including without limitation the rights to
use, copy, modify, merge, publish, distribute, sublicense, and/or sell copies of
the Software, and to permit persons to whom the Software is furnished to do so,
subject to the following conditions:

The above copyright notice and this permission notice shall be included in all
copies or substantial portions of the Software.

THE SOFTWARE IS PROVIDED "AS IS", WITHOUT WARRANTY OF ANY KIND, EXPRESS OR
IMPLIED, INCLUDING BUT NOT LIMITED TO THE WARRANTIES OF MERCHANTABILITY, FITNESS
FOR A PARTICULAR PURPOSE AND NONINFRINGEMENT. IN NO EVENT SHALL THE AUTHORS OR
COPYRIGHT HOLDERS BE LIABLE FOR ANY CLAIM, DAMAGES OR OTHER LIABILITY, WHETHER
IN AN ACTION OF CONTRACT, TORT OR OTHERWISE, ARISING FROM, OUT OF OR IN
CONNECTION WITH THE SOFTWARE OR THE USE OR OTHER DEALINGS IN THE SOFTWARE.

-----

This product includes murmurhash3.
MurmurHash3 was written by Austin Appleby, and is placed in the public domain. The author
hereby disclaims copyright to this source code.

-----

This product includes libxml2.

Copyright (C) 1998-2012 Daniel Veillard. All Rights Reserved.

Permission is hereby granted, free of charge, to any person obtaining a copy
of this software and associated documentation files (the "Software"), to deal
in the Software without restriction, including without limitation the rights
to use, copy, modify, merge, publish, distribute, sublicense, and/or sell

```

copies of the Software, and to permit persons to whom the Software is furnished to do so, subject to the following conditions:

The above copyright notice and this permission notice shall be included in all copies or substantial portions of the Software.

THE SOFTWARE IS PROVIDED "AS IS", WITHOUT WARRANTY OF ANY KIND, EXPRESS OR IMPLIED, INCLUDING BUT NOT LIMITED TO THE WARRANTIES OF MERCHANTABILITY, FITNESS FOR A PARTICULAR PURPOSE AND NONINFRINGEMENT. IN NO EVENT SHALL THE AUTHORS OR COPYRIGHT HOLDERS BE LIABLE FOR ANY CLAIM, DAMAGES OR OTHER LIABILITY, WHETHER IN AN ACTION OF CONTRACT, TORT OR OTHERWISE, ARISING FROM, OUT OF OR IN CONNECTION WITH THE SOFTWARE OR THE USE OR OTHER DEALINGS IN THE SOFTWARE.

-----  
 This product includes zlib.

(C) 1995-2022 Jean-loup Gailly and Mark Adler

This software is provided 'as-is', without any express or implied warranty. In no event will the authors be held liable for any damages arising from the use of this software.

Permission is granted to anyone to use this software for any purpose, including commercial applications, and to alter it and redistribute it freely, subject to the following restrictions:

1. The origin of this software must not be misrepresented; you must not claim that you wrote the original software. If you use this software in a product, an acknowledgment in the product documentation would be appreciated but is not required.
2. Altered source versions must be plainly marked as such, and must not be misrepresented as being the original software.
3. This notice may not be removed or altered from any source distribution.

Jean-loup Gailly                      Mark Adler  
 jloup@gzip.org                        madler@alumni.caltech.edu

-----  
 This product includes Botan.

Copyright (C) 1999-2020 The Botan Authors  
 All rights reserved.

Redistribution and use in source and binary forms, with or without modification, are permitted provided that the following conditions are met:

1. Redistributions of source code must retain the above copyright notice, this list of conditions, and the following disclaimer.
2. Redistributions in binary form must reproduce the above copyright notice, this list of conditions, and the following disclaimer in the documentation and/or other materials provided with the distribution.

THIS SOFTWARE IS PROVIDED BY THE COPYRIGHT HOLDERS AND CONTRIBUTORS "AS IS" AND ANY EXPRESS OR IMPLIED WARRANTIES, INCLUDING, BUT NOT LIMITED TO, THE IMPLIED WARRANTIES OF MERCHANTABILITY AND FITNESS FOR A PARTICULAR PURPOSE ARE DISCLAIMED. IN NO EVENT SHALL THE COPYRIGHT HOLDER OR CONTRIBUTORS BE LIABLE FOR ANY DIRECT, INDIRECT, INCIDENTAL, SPECIAL, EXEMPLARY, OR CONSEQUENTIAL DAMAGES (INCLUDING, BUT NOT LIMITED TO, PROCUREMENT OF SUBSTITUTE GOODS OR SERVICES; LOSS OF USE, DATA, OR PROFITS; OR BUSINESS INTERRUPTION) HOWEVER CAUSED AND ON ANY THEORY OF LIABILITY, WHETHER IN CONTRACT, STRICT LIABILITY, OR TORT (INCLUDING NEGLIGENCE OR OTHERWISE) ARISING IN ANY WAY OUT OF THE USE OF THIS SOFTWARE, EVEN IF ADVISED OF THE POSSIBILITY OF SUCH DAMAGE.

-----  
 This product includes GLEW: The OpenGL Extension Wrangler Library.

The OpenGL Extension Wrangler Library  
 Copyright (C) 2002-2007, Milan Ikits <milan ikits[at]ieee org>  
 Copyright (C) 2002-2007, Marcelo E. Magallon <mmagallo[at]debian org>  
 Copyright (C) 2002, Lev Povalahev  
 All rights reserved.

Redistribution and use in source and binary forms, with or without modification, are permitted provided that the following conditions are met:

- \* Redistributions of source code must retain the above copyright notice, this list of conditions and the following disclaimer.
- \* Redistributions in binary form must reproduce the above copyright notice, this list of conditions and the following disclaimer in the documentation and/or other materials provided with the distribution.
- \* The name of the author may be used to endorse or promote products derived from this software without specific prior written permission.

THIS SOFTWARE IS PROVIDED BY THE COPYRIGHT HOLDERS AND CONTRIBUTORS "AS IS" AND ANY EXPRESS OR IMPLIED WARRANTIES, INCLUDING, BUT NOT LIMITED TO, THE IMPLIED WARRANTIES OF MERCHANTABILITY AND FITNESS FOR A PARTICULAR PURPOSE ARE DISCLAIMED. IN NO EVENT SHALL THE COPYRIGHT OWNER OR CONTRIBUTORS BE LIABLE FOR ANY DIRECT, INDIRECT, INCIDENTAL, SPECIAL, EXEMPLARY, OR CONSEQUENTIAL DAMAGES (INCLUDING, BUT NOT LIMITED TO, PROCUREMENT OF SUBSTITUTE GOODS OR SERVICES; LOSS OF USE, DATA, OR PROFITS; OR BUSINESS INTERRUPTION) HOWEVER CAUSED AND ON ANY THEORY OF LIABILITY, WHETHER IN CONTRACT, STRICT LIABILITY, OR TORT (INCLUDING NEGLIGENCE OR OTHERWISE) ARISING IN ANY WAY OUT OF THE USE OF THIS SOFTWARE, EVEN IF ADVISED OF THE POSSIBILITY OF SUCH DAMAGE.

Mesa 3-D graphics library  
Version: 7.0

Copyright (C) 1999-2007 Brian Paul All Rights Reserved.

Permission is hereby granted, free of charge, to any person obtaining a copy of this software and associated documentation files (the "Software"), to deal in the Software without restriction, including without limitation the rights to use, copy, modify, merge, publish, distribute, sublicense, and/or sell copies of the Software, and to permit persons to whom the Software is furnished to do so, subject to the following conditions:

The above copyright notice and this permission notice shall be included in all copies or substantial portions of the Software.

THE SOFTWARE IS PROVIDED "AS IS", WITHOUT WARRANTY OF ANY KIND, EXPRESS OR IMPLIED, INCLUDING BUT NOT LIMITED TO THE WARRANTIES OF MERCHANTABILITY, FITNESS FOR A PARTICULAR PURPOSE AND NONINFRINGEMENT. IN NO EVENT SHALL BRIAN PAUL BE LIABLE FOR ANY CLAIM, DAMAGES OR OTHER LIABILITY, WHETHER IN AN ACTION OF CONTRACT, TORT OR OTHERWISE, ARISING FROM, OUT OF OR IN CONNECTION WITH THE SOFTWARE OR THE USE OR OTHER DEALINGS IN THE SOFTWARE.

Copyright (c) 2007 The Khronos Group Inc.

Permission is hereby granted, free of charge, to any person obtaining a copy of this software and/or associated documentation files (the "Materials"), to deal in the Materials without restriction, including without limitation the rights to use, copy, modify, merge, publish, distribute, sublicense, and/or sell copies of the Materials, and to permit persons to whom the Materials are furnished to do so, subject to the following conditions:

The above copyright notice and this permission notice shall be included in all copies or substantial portions of the Materials.

THE MATERIALS ARE PROVIDED "AS IS", WITHOUT WARRANTY OF ANY KIND, EXPRESS OR IMPLIED, INCLUDING BUT NOT LIMITED TO THE WARRANTIES OF MERCHANTABILITY, FITNESS FOR A PARTICULAR PURPOSE AND NONINFRINGEMENT. IN NO EVENT SHALL THE AUTHORS OR COPYRIGHT HOLDERS BE LIABLE FOR ANY CLAIM, DAMAGES OR OTHER LIABILITY, WHETHER IN AN ACTION OF CONTRACT, TORT OR OTHERWISE, ARISING FROM, OUT OF OR IN CONNECTION WITH THE MATERIALS OR THE USE OR OTHER DEALINGS IN THE MATERIALS.

-----  
This product includes JPEGLib.  
This software is copyright (C) 1991-2016, Thomas G. Lane, Guido Vollbeding.  
All Rights Reserved.

This software is based in part on the work of the Independent JPEG Group.  
-----

This product includes tesseract.

Copyright (C) 2016 Google, Inc. Licensed under the Apache License, Version 2.0

-----  
 This product includes robin-map.

MIT License

Copyright (c) 2017 Tessil

Permission is hereby granted, free of charge, to any person obtaining a copy of this software and associated documentation files (the "Software"), to deal in the Software without restriction, including without limitation the rights to use, copy, modify, merge, publish, distribute, sublicense, and/or sell copies of the Software, and to permit persons to whom the Software is furnished to do so, subject to the following conditions:

The above copyright notice and this permission notice shall be included in all copies or substantial portions of the Software.

THE SOFTWARE IS PROVIDED "AS IS", WITHOUT WARRANTY OF ANY KIND, EXPRESS OR IMPLIED, INCLUDING BUT NOT LIMITED TO THE WARRANTIES OF MERCHANTABILITY, FITNESS FOR A PARTICULAR PURPOSE AND NONINFRINGEMENT. IN NO EVENT SHALL THE AUTHORS OR COPYRIGHT HOLDERS BE LIABLE FOR ANY CLAIM, DAMAGES OR OTHER LIABILITY, WHETHER IN AN ACTION OF CONTRACT, TORT OR OTHERWISE, ARISING FROM, OUT OF OR IN CONNECTION WITH THE SOFTWARE OR THE USE OR OTHER DEALINGS IN THE SOFTWARE.

-----  
 This product includes LibTIFF.

Copyright (c) 1988-1997 Sam Leffler  
 Copyright (c) 1991-1997 Silicon Graphics, Inc.

Permission to use, copy, modify, distribute, and sell this software and its documentation for any purpose is hereby granted without fee, provided that (i) the above copyright notices and this permission notice appear in all copies of the software and related documentation, and (ii) the names of Sam Leffler and Silicon Graphics may not be used in any advertising or publicity relating to the software without the specific, prior written permission of Sam Leffler and Silicon Graphics.

THE SOFTWARE IS PROVIDED "AS-IS" AND WITHOUT WARRANTY OF ANY KIND, EXPRESS, IMPLIED OR OTHERWISE, INCLUDING WITHOUT LIMITATION, ANY WARRANTY OF MERCHANTABILITY OR FITNESS FOR A PARTICULAR PURPOSE.

IN NO EVENT SHALL SAM LEFFLER OR SILICON GRAPHICS BE LIABLE FOR ANY SPECIAL, INCIDENTAL, INDIRECT OR CONSEQUENTIAL DAMAGES OF ANY KIND, OR ANY DAMAGES WHATSOEVER RESULTING FROM LOSS OF USE, DATA OR PROFITS, WHETHER OR NOT ADVISED OF THE POSSIBILITY OF DAMAGE, AND ON ANY THEORY OF LIABILITY, ARISING OUT OF OR IN CONNECTION WITH THE USE OR PERFORMANCE OF THIS SOFTWARE.

-----  
 This product includes cereal.

Copyright (c) 2013-2022, Randolph Voorhies, Shane Grant  
 All rights reserved.

Redistribution and use in source and binary forms, with or without modification, are permitted provided that the following conditions are met:

- \* Redistributions of source code must retain the above copyright notice, this list of conditions and the following disclaimer.
- \* Redistributions in binary form must reproduce the above copyright notice, this list of conditions and the following disclaimer in the documentation and/or other materials provided with the distribution.
- \* Neither the name of the copyright holder nor the names of its contributors may be used to endorse or promote products derived from this software without specific prior written permission.

THIS SOFTWARE IS PROVIDED BY THE COPYRIGHT HOLDERS AND CONTRIBUTORS "AS IS" AND ANY EXPRESS OR IMPLIED WARRANTIES, INCLUDING, BUT NOT LIMITED TO, THE IMPLIED

```

WARRANTIES OF MERCHANTABILITY AND FITNESS FOR A PARTICULAR PURPOSE ARE
DISCLAIMED. IN NO EVENT SHALL THE COPYRIGHT HOLDER OR CONTRIBUTORS BE LIABLE FOR ANY
DIRECT, INDIRECT, INCIDENTAL, SPECIAL, EXEMPLARY, OR CONSEQUENTIAL DAMAGES
(INCLUDING, BUT NOT LIMITED TO, PROCUREMENT OF SUBSTITUTE GOODS OR SERVICES;
LOSS OF USE, DATA, OR PROFITS; OR BUSINESS INTERRUPTION) HOWEVER CAUSED AND
ON ANY THEORY OF LIABILITY, WHETHER IN CONTRACT, STRICT LIABILITY, OR TORT
(INCLUDING NEGLIGENCE OR OTHERWISE) ARISING IN ANY WAY OUT OF THE USE OF THIS
SOFTWARE, EVEN IF ADVISED OF THE POSSIBILITY OF SUCH DAMAGE.

-----

This product includes gSOAP.

    EXHIBIT B.

    Part of the software embedded in this product is gSOAP software.
    Portions created by gSOAP are Copyright (C) 2001-2007 Robert A. van Engelen,
    Genivia inc. All Rights Reserved.

    THE SOFTWARE IN THIS PRODUCT WAS IN PART PROVIDED BY GENIVIA INC AND ANY EXPRESS
    OR IMPLIED WARRANTIES, INCLUDING, BUT NOT LIMITED TO, THE IMPLIED WARRANTIES OF
    MERCHANTABILITY AND FITNESS FOR A PARTICULAR PURPOSE ARE DISCLAIMED. IN NO EVENT SHALL
    THE AUTHOR BE LIABLE FOR ANY DIRECT, INDIRECT, INCIDENTAL, SPECIAL, EXEMPLARY, OR
    CONSEQUENTIAL DAMAGES (INCLUDING, BUT NOT LIMITED TO, PROCUREMENT OF SUBSTITUTE GOODS
    OR SERVICES; LOSS OF USE, DATA, OR PROFITS; OR BUSINESS INTERRUPTION) HOWEVER CAUSED AND
    ON ANY THEORY OF LIABILITY, WHETHER IN CONTRACT, STRICT LIABILITY, OR TORT (INCLUDING
    NEGLIGENCE OR OTHERWISE) ARISING IN ANY WAY OUT OF THE USE OF THIS SOFTWARE, EVEN IF
    ADVISED OF THE POSSIBILITY OF SUCH DAMAGE.

-----

This product includes llvm.

    University of Illinois/NCSA
    Open Source License

    Copyright (c) 2003-2019 University of Illinois at Urbana-Champaign.
    All rights reserved.

    Developed by:

        LLVM Team

        University of Illinois at Urbana-Champaign

        http://llvm.org

    Permission is hereby granted, free of charge, to any person obtaining a copy of
    this software and associated documentation files (the "Software"), to deal with
    the Software without restriction, including without limitation the rights to
    use, copy, modify, merge, publish, distribute, sublicense, and/or sell copies
    of the Software, and to permit persons to whom the Software is furnished to do
    so, subject to the following conditions:

    * Redistributions of source code must retain the above copyright notice,
      this list of conditions and the following disclaimers.

    * Redistributions in binary form must reproduce the above copyright notice,
      this list of conditions and the following disclaimers in the
      documentation and/or other materials provided with the distribution.

    * Neither the names of the LLVM Team, University of Illinois at
      Urbana-Champaign, nor the names of its contributors may be used to
      endorse or promote products derived from this Software without specific
      prior written permission.

    THE SOFTWARE IS PROVIDED "AS IS", WITHOUT WARRANTY OF ANY KIND, EXPRESS OR
    IMPLIED, INCLUDING BUT NOT LIMITED TO THE WARRANTIES OF MERCHANTABILITY, FITNESS
    FOR A PARTICULAR PURPOSE AND NONINFRINGEMENT. IN NO EVENT SHALL THE
    CONTRIBUTORS OR COPYRIGHT HOLDERS BE LIABLE FOR ANY CLAIM, DAMAGES OR OTHER
    LIABILITY, WHETHER IN AN ACTION OF CONTRACT, TORT OR OTHERWISE, ARISING FROM,
    OUT OF OR IN CONNECTION WITH THE SOFTWARE OR THE USE OR OTHER DEALINGS WITH THE
    SOFTWARE.

-----

This product includes OpenSSL.

```



Copyright (c) 1998-2017 The OpenSSL Project. All rights reserved.

Redistribution and use in source and binary forms, with or without modification, are permitted provided that the following conditions are met:

1. Redistributions of source code must retain the above copyright notice, this list of conditions and the following disclaimer.
2. Redistributions in binary form must reproduce the above copyright notice, this list of conditions and the following disclaimer in the documentation and/or other materials provided with the distribution.
3. All advertising materials mentioning features or use of this software must display the following acknowledgment:  
"This product includes software developed by the OpenSSL Project for use in the OpenSSL Toolkit. (<http://www.openssl.org/>)"
4. The names "OpenSSL Toolkit" and "OpenSSL Project" must not be used to endorse or promote products derived from this software without prior written permission. For written permission, please contact [openssl-core@openssl.org](mailto:openssl-core@openssl.org).
5. Products derived from this software may not be called "OpenSSL" nor may "OpenSSL" appear in their names without prior written permission of the OpenSSL Project.
6. Redistributions of any form whatsoever must retain the following acknowledgment:  
"This product includes software developed by the OpenSSL Project for use in the OpenSSL Toolkit (<http://www.openssl.org/>)"

THIS SOFTWARE IS PROVIDED BY THE OPENSSL PROJECT ``AS IS'' AND ANY EXPRESSED OR IMPLIED WARRANTIES, INCLUDING, BUT NOT LIMITED TO, THE IMPLIED WARRANTIES OF MERCHANTABILITY AND FITNESS FOR A PARTICULAR PURPOSE ARE DISCLAIMED. IN NO EVENT SHALL THE OPENSSL PROJECT OR ITS CONTRIBUTORS BE LIABLE FOR ANY DIRECT, INDIRECT, INCIDENTAL, SPECIAL, EXEMPLARY, OR CONSEQUENTIAL DAMAGES (INCLUDING, BUT NOT LIMITED TO, PROCUREMENT OF SUBSTITUTE GOODS OR SERVICES; LOSS OF USE, DATA, OR PROFITS; OR BUSINESS INTERRUPTION) HOWEVER CAUSED AND ON ANY THEORY OF LIABILITY, WHETHER IN CONTRACT, STRICT LIABILITY, OR TORT (INCLUDING NEGLIGENCE OR OTHERWISE) ARISING IN ANY WAY OUT OF THE USE OF THIS SOFTWARE, EVEN IF ADVISED OF THE POSSIBILITY OF SUCH DAMAGE.

-----  
This product includes OpenSSL.

Copyright (C) 1995-1998 Eric Young ([eay@cryptsoft.com](mailto:eay@cryptsoft.com))  
All rights reserved.

Redistribution and use in source and binary forms, with or without modification, are permitted provided that the following conditions are met:

1. Redistributions of source code must retain the copyright notice, this list of conditions and the following disclaimer.
2. Redistributions in binary form must reproduce the above copyright notice, this list of conditions and the following disclaimer in the documentation and/or other materials provided with the distribution.
3. All advertising materials mentioning features or use of this software must display the following acknowledgement:  
"This product includes cryptographic software written by Eric Young ([eay@cryptsoft.com](mailto:eay@cryptsoft.com))"  
The word 'cryptographic' can be left out if the routines from the library being used are not cryptographic related :-).  
4. If you include any Windows specific code (or a derivative thereof) from the apps directory (application code) you must include an acknowledgement:  
"This product includes software written by Tim Hudson ([tjh@cryptsoft.com](mailto:tjh@cryptsoft.com))"

THIS SOFTWARE IS PROVIDED BY ERIC YOUNG ``AS IS'' AND ANY EXPRESS OR IMPLIED WARRANTIES, INCLUDING, BUT NOT LIMITED TO, THE IMPLIED WARRANTIES OF MERCHANTABILITY AND FITNESS FOR A PARTICULAR PURPOSE ARE DISCLAIMED. IN NO EVENT SHALL THE AUTHOR OR CONTRIBUTORS BE LIABLE FOR ANY DIRECT, INDIRECT, INCIDENTAL, SPECIAL, EXEMPLARY, OR CONSEQUENTIAL

DAMAGES (INCLUDING, BUT NOT LIMITED TO, PROCUREMENT OF SUBSTITUTE GOODS OR SERVICES; LOSS OF USE, DATA, OR PROFITS; OR BUSINESS INTERRUPTION) HOWEVER CAUSED AND ON ANY THEORY OF LIABILITY, WHETHER IN CONTRACT, STRICT LIABILITY, OR TORT (INCLUDING NEGLIGENCE OR OTHERWISE) ARISING IN ANY WAY OUT OF THE USE OF THIS SOFTWARE, EVEN IF ADVISED OF THE POSSIBILITY OF SUCH DAMAGE.

-----  
 This product includes OpenImageIO.

Copyright (c) 2008-present by Contributors to the OpenImageIO project.  
 All Rights Reserved.

Redistribution and use in source and binary forms, with or without modification, are permitted provided that the following conditions are met:

1. Redistributions of source code must retain the above copyright notice, this list of conditions and the following disclaimer.
2. Redistributions in binary form must reproduce the above copyright notice, this list of conditions and the following disclaimer in the documentation and/or other materials provided with the distribution.
3. Neither the name of the copyright holder nor the names of its contributors may be used to endorse or promote products derived from this software without specific prior written permission.

THIS SOFTWARE IS PROVIDED BY THE COPYRIGHT HOLDERS AND CONTRIBUTORS "AS IS" AND ANY EXPRESS OR IMPLIED WARRANTIES, INCLUDING, BUT NOT LIMITED TO, THE IMPLIED WARRANTIES OF MERCHANTABILITY AND FITNESS FOR A PARTICULAR PURPOSE ARE DISCLAIMED. IN NO EVENT SHALL THE COPYRIGHT HOLDER OR CONTRIBUTORS BE LIABLE FOR ANY DIRECT, INDIRECT, INCIDENTAL, SPECIAL, EXEMPLARY, OR CONSEQUENTIAL DAMAGES (INCLUDING, BUT NOT LIMITED TO, PROCUREMENT OF SUBSTITUTE GOODS OR SERVICES; LOSS OF USE, DATA, OR PROFITS; OR BUSINESS INTERRUPTION) HOWEVER CAUSED AND ON ANY THEORY OF LIABILITY, WHETHER IN CONTRACT, STRICT LIABILITY, OR TORT (INCLUDING NEGLIGENCE OR OTHERWISE) ARISING IN ANY WAY OUT OF THE USE OF THIS SOFTWARE, EVEN IF ADVISED OF THE POSSIBILITY OF SUCH DAMAGE.

-----  
 This product includes lzw-ab.

Copyright (c) David Bryant  
 All rights reserved.

Redistribution and use in source and binary forms, with or without modification, are permitted provided that the following conditions are met:

- \* Redistributions of source code must retain the above copyright notice, this list of conditions and the following disclaimer.
- \* Redistributions in binary form must reproduce the above copyright notice, this list of conditions and the following disclaimer in the documentation and/or other materials provided with the distribution.
- \* Neither the name of Conifer Software nor the names of its contributors may be used to endorse or promote products derived from this software without specific prior written permission.

THIS SOFTWARE IS PROVIDED BY THE COPYRIGHT HOLDERS AND CONTRIBUTORS "AS IS" AND ANY EXPRESS OR IMPLIED WARRANTIES, INCLUDING, BUT NOT LIMITED TO, THE IMPLIED WARRANTIES OF MERCHANTABILITY AND FITNESS FOR A PARTICULAR PURPOSE ARE DISCLAIMED. IN NO EVENT SHALL THE REGENTS OR CONTRIBUTORS BE LIABLE FOR ANY DIRECT, INDIRECT, INCIDENTAL, SPECIAL, EXEMPLARY, OR CONSEQUENTIAL DAMAGES (INCLUDING, BUT NOT LIMITED TO, PROCUREMENT OF SUBSTITUTE GOODS OR SERVICES; LOSS OF USE, DATA, OR PROFITS; OR BUSINESS INTERRUPTION) HOWEVER CAUSED AND ON ANY THEORY OF LIABILITY, WHETHER IN CONTRACT, STRICT LIABILITY, OR TORT (INCLUDING NEGLIGENCE OR OTHERWISE) ARISING IN ANY WAY OUT OF THE USE OF THIS SOFTWARE, EVEN IF ADVISED OF THE POSSIBILITY OF SUCH DAMAGE.

-----  
 This product includes xxHash.

xxHash Library  
 Copyright (c) 2012-2014, Yann Collet  
 All rights reserved.

```

Redistribution and use in source and binary forms, with or without modification,
are permitted provided that the following conditions are met:

* Redistributions of source code must retain the above copyright notice, this
list of conditions and the following disclaimer.

* Redistributions in binary form must reproduce the above copyright notice, this
list of conditions and the following disclaimer in the documentation and/or
other materials provided with the distribution.

THIS SOFTWARE IS PROVIDED BY THE COPYRIGHT HOLDERS AND CONTRIBUTORS "AS IS" AND
ANY EXPRESS OR IMPLIED WARRANTIES, INCLUDING, BUT NOT LIMITED TO, THE IMPLIED
WARRANTIES OF MERCHANTABILITY AND FITNESS FOR A PARTICULAR PURPOSE ARE
DISCLAIMED. IN NO EVENT SHALL THE COPYRIGHT HOLDER OR CONTRIBUTORS BE LIABLE FOR
ANY DIRECT, INDIRECT, INCIDENTAL, SPECIAL, EXEMPLARY, OR CONSEQUENTIAL DAMAGES
(INCLUDING, BUT NOT LIMITED TO, PROCUREMENT OF SUBSTITUTE GOODS OR SERVICES;
LOSS OF USE, DATA, OR PROFITS; OR BUSINESS INTERRUPTION) HOWEVER CAUSED AND ON
ANY THEORY OF LIABILITY, WHETHER IN CONTRACT, STRICT LIABILITY, OR TORT
(INCLUDING NEGLIGENCE OR OTHERWISE) ARISING IN ANY WAY OUT OF THE USE OF THIS
SOFTWARE, EVEN IF ADVISED OF THE POSSIBILITY OF SUCH DAMAGE.

-----

This product includes lz4.

    Copyright (C) 2011-present, Yann Collet.

    BSD 2-Clause License (http://www.opensource.org/licenses/bsd-license.php)

    Redistribution and use in source and binary forms, with or without
    modification, are permitted provided that the following conditions are
    met:

        * Redistributions of source code must retain the above copyright
        notice, this list of conditions and the following disclaimer.
        * Redistributions in binary form must reproduce the above
        copyright notice, this list of conditions and the following disclaimer
        in the documentation and/or other materials provided with the
        distribution.

    THIS SOFTWARE IS PROVIDED BY THE COPYRIGHT HOLDERS AND CONTRIBUTORS
    "AS IS" AND ANY EXPRESS OR IMPLIED WARRANTIES, INCLUDING, BUT NOT
    LIMITED TO, THE IMPLIED WARRANTIES OF MERCHANTABILITY AND FITNESS FOR
    A PARTICULAR PURPOSE ARE DISCLAIMED. IN NO EVENT SHALL THE COPYRIGHT
    OWNER OR CONTRIBUTORS BE LIABLE FOR ANY DIRECT, INDIRECT, INCIDENTAL,
    SPECIAL, EXEMPLARY, OR CONSEQUENTIAL DAMAGES (INCLUDING, BUT NOT
    LIMITED TO, PROCUREMENT OF SUBSTITUTE GOODS OR SERVICES; LOSS OF USE,
    DATA, OR PROFITS; OR BUSINESS INTERRUPTION) HOWEVER CAUSED AND ON ANY
    THEORY OF LIABILITY, WHETHER IN CONTRACT, STRICT LIABILITY, OR TORT
    (INCLUDING NEGLIGENCE OR OTHERWISE) ARISING IN ANY WAY OUT OF THE USE
    OF THIS SOFTWARE, EVEN IF ADVISED OF THE POSSIBILITY OF SUCH DAMAGE.

-----

This product includes ICU.

    Copyright (c) 1995-2014 International Business Machines Corporation and others
    All rights reserved.

    Permission is hereby granted, free of charge, to any person obtaining a copy of
    this software and associated documentation files (the "Software"), to deal in the
    Software without restriction, including without limitation the rights to use,
    copy, modify, merge, publish, distribute, and/or sell copies of the Software, and
    to permit persons to whom the Software is furnished to do so, provided that the
    above copyright notice(s) and this permission notice appear in all copies of the
    Software and that both the above copyright notice(s) and this permission notice
    appear in supporting documentation.

    THE SOFTWARE IS PROVIDED "AS IS", WITHOUT WARRANTY OF ANY KIND, EXPRESS OR
    IMPLIED, INCLUDING BUT NOT LIMITED TO THE WARRANTIES OF MERCHANTABILITY, FITNESS
    FOR A PARTICULAR PURPOSE AND NONINFRINGEMENT OF THIRD PARTY RIGHTS. IN NO EVENT
    SHALL THE COPYRIGHT HOLDER OR HOLDERS INCLUDED IN THIS NOTICE BE LIABLE FOR ANY
    CLAIM, OR ANY SPECIAL INDIRECT OR CONSEQUENTIAL DAMAGES, OR ANY DAMAGES
    WHATSOEVER RESULTING FROM LOSS OF USE, DATA OR PROFITS, WHETHER IN AN ACTION OF
    CONTRACT, NEGLIGENCE OR OTHER TORTIOUS ACTION, ARISING OUT OF OR IN CONNECTION
    WITH THE USE OR PERFORMANCE OF THIS SOFTWARE.

```



DAMAGES (INCLUDING, BUT NOT LIMITED TO, PROCUREMENT OF SUBSTITUTE GOODS OR SERVICES; LOSS OF USE, DATA, OR PROFITS; OR BUSINESS INTERRUPTION) HOWEVER CAUSED AND ON ANY THEORY OF LIABILITY, WHETHER IN CONTRACT, STRICT LIABILITY, OR TORT (INCLUDING NEGLIGENCE OR OTHERWISE) ARISING IN ANY WAY OUT OF THE USE OF THIS SOFTWARE, EVEN IF ADVISED OF THE POSSIBILITY OF SUCH DAMAGE.

-----  
 This product includes JBIG2Lib.

Portions of this product copyrights (C) 2002 Glyph & Cog, LLC.

-----  
 This product includes ICC Profiles.

Some ICC Profiles were created by FFEI Ltd. ([www.ffei.co.uk](http://www.ffei.co.uk)) using Fujifilm ColourKit Profiler Suite ([www.colourprofiling.com](http://www.colourprofiling.com))

-----  
 This product includes ICC Profiles.

Some ICC profiles are copyright (C) by European Color Initiative, [www.eci.org](http://www.eci.org)

-----  
 This product includes ICC Profiles.

Some ICC profiles are copyright (C) of WAN-IFRA, [www.wan-ifra.org](http://www.wan-ifra.org)

-----  
 This product includes ICC Profiles.

Some ICC profiles are copyright (C) IDEAlliance(R). G7(R), GRACol(R) and SWOP(R) are all registered trademarks of IDEAlliance(C).

-----  
 This product includes PANTONE Color Libraries.

PANTONE® and other Pantone trademarks are the property of Pantone LLC. Pantone is a wholly owned subsidiary of X-Rite, Incorporated.

-----  
 This product includes PCRE.

Copyright (c) 1997-2016 University of Cambridge  
 All rights reserved.

Copyright(c) 2010-2016 Zoltan Herczeg  
 All rights reserved.

Copyright(c) 2009-2016 Zoltan Herczeg  
 All rights reserved.

Redistribution and use in source and binary forms, with or without modification, are permitted provided that the following conditions are met:

- \* Redistributions of source code must retain the above copyright notice, this list of conditions and the following disclaimer.
- \* Redistributions in binary form must reproduce the above copyright notice, this list of conditions and the following disclaimer in the documentation and/or other materials provided with the distribution.
- \* Neither the name of the University of Cambridge nor the names of any contributors may be used to endorse or promote products derived from this software without specific prior written permission.

THIS SOFTWARE IS PROVIDED BY THE COPYRIGHT HOLDERS AND CONTRIBUTORS "AS IS" AND ANY EXPRESS OR IMPLIED WARRANTIES, INCLUDING, BUT NOT LIMITED TO, THE IMPLIED WARRANTIES OF MERCHANTABILITY AND FITNESS FOR A PARTICULAR PURPOSE ARE DISCLAIMED. IN NO EVENT SHALL THE COPYRIGHT OWNER OR CONTRIBUTORS BE LIABLE FOR ANY DIRECT, INDIRECT, INCIDENTAL, SPECIAL, EXEMPLARY, OR

CONSEQUENTIAL DAMAGES (INCLUDING, BUT NOT LIMITED TO, PROCUREMENT OF SUBSTITUTE GOODS OR SERVICES; LOSS OF USE, DATA, OR PROFITS; OR BUSINESS INTERRUPTION) HOWEVER CAUSED AND ON ANY THEORY OF LIABILITY, WHETHER IN CONTRACT, STRICT LIABILITY, OR TORT (INCLUDING NEGLIGENCE OR OTHERWISE) ARISING IN ANY WAY OUT OF THE USE OF THIS SOFTWARE, EVEN IF ADVISED OF THE POSSIBILITY OF SUCH DAMAGE.

-----  
 This product includes XercesC.

NOTICE file corresponding to section 4(d) of the Apache License, Version 2.0, in this case for the Apache Xerces distribution.

This product includes software developed by  
 The Apache Software Foundation (<http://www.apache.org/>).

Portions of this software were originally based on the following:  
 - software copyright (c) 1999, IBM Corporation., <http://www.ibm.com>.

-----  
 This product includes OpenShadingLanguage.

BSD 3-Clause License

Copyright (c) 2009-2019 Sony Pictures Imageworks Inc., et al.  
 All Rights Reserved.

Redistribution and use in source and binary forms, with or without modification, are permitted provided that the following conditions are met:

1. Redistributions of source code must retain the above copyright notice, this list of conditions and the following disclaimer.
2. Redistributions in binary form must reproduce the above copyright notice, this list of conditions and the following disclaimer in the documentation and/or other materials provided with the distribution.
3. Neither the name of the copyright holder nor the names of its contributors may be used to endorse or promote products derived from this software without specific prior written permission.

THIS SOFTWARE IS PROVIDED BY THE COPYRIGHT HOLDERS AND CONTRIBUTORS "AS IS" AND ANY EXPRESS OR IMPLIED WARRANTIES, INCLUDING, BUT NOT LIMITED TO, THE IMPLIED WARRANTIES OF MERCHANTABILITY AND FITNESS FOR A PARTICULAR PURPOSE ARE DISCLAIMED. IN NO EVENT SHALL THE COPYRIGHT HOLDER OR CONTRIBUTORS BE LIABLE FOR ANY DIRECT, INDIRECT, INCIDENTAL, SPECIAL, EXEMPLARY, OR CONSEQUENTIAL DAMAGES (INCLUDING, BUT NOT LIMITED TO, PROCUREMENT OF SUBSTITUTE GOODS OR SERVICES; LOSS OF USE, DATA, OR PROFITS; OR BUSINESS INTERRUPTION) HOWEVER CAUSED AND ON ANY THEORY OF LIABILITY, WHETHER IN CONTRACT, STRICT LIABILITY, OR TORT (INCLUDING NEGLIGENCE OR OTHERWISE) ARISING IN ANY WAY OUT OF THE USE OF THIS SOFTWARE, EVEN IF ADVISED OF THE POSSIBILITY OF SUCH DAMAGE.

-----  
 This product includes leptonica.

- Copyright (C) 2001-2016 Leptonica. All rights reserved.
- 
- Redistribution and use in source and binary forms, with or without modification, are permitted provided that the following conditions are met:
- 1. Redistributions of source code must retain the above copyright notice, this list of conditions and the following disclaimer.
- 2. Redistributions in binary form must reproduce the above copyright notice, this list of conditions and the following disclaimer in the documentation and/or other materials provided with the distribution.
- 
- THIS SOFTWARE IS PROVIDED BY THE COPYRIGHT HOLDERS AND CONTRIBUTORS ``AS IS'' AND ANY EXPRESS OR IMPLIED WARRANTIES, INCLUDING, BUT NOT LIMITED TO, THE IMPLIED WARRANTIES OF MERCHANTABILITY AND FITNESS FOR A PARTICULAR PURPOSE ARE DISCLAIMED. IN NO EVENT SHALL ANY CONTRIBUTORS BE LIABLE FOR ANY DIRECT, INDIRECT, INCIDENTAL, SPECIAL, EXEMPLARY, OR CONSEQUENTIAL DAMAGES (INCLUDING, BUT NOT LIMITED TO, PROCUREMENT OF SUBSTITUTE GOODS OR SERVICES; LOSS OF USE, DATA, OR

- PROFITS; OR BUSINESS INTERRUPTION) HOWEVER CAUSED AND ON ANY THEORY
- OF LIABILITY, WHETHER IN CONTRACT, STRICT LIABILITY, OR TORT (INCLUDING
- NEGLIGENCE OR OTHERWISE) ARISING IN ANY WAY OUT OF THE USE OF THIS
- SOFTWARE, EVEN IF ADVISED OF THE POSSIBILITY OF SUCH DAMAGE.

-----

This product includes FCollada.

Copyright 2006 Feeling Software. All rights reserved.

Copyright 2005-2006 Feeling Software and  
Copyright 2005-2006 Autodesk Media Entertainment.

Copyright (C) 1998-2003 Daniel Veillard. All Rights Reserved.

Permission is hereby granted, free of charge, to any person obtaining a copy of this software and associated documentation files (the "Software"), to deal in the Software without restriction, including without limitation the rights to use, copy, modify, merge, publish, distribute, sublicense, and/or sell copies of the Software, and to permit persons to whom the Software is furnished to do so, subject to the following conditions:

The above copyright notice and this permission notice shall be included in all copies or substantial portions of the Software.

THE SOFTWARE IS PROVIDED "AS IS", WITHOUT WARRANTY OF ANY KIND, EXPRESS OR IMPLIED, INCLUDING BUT NOT LIMITED TO THE WARRANTIES OF MERCHANTABILITY, FITNESS FOR A PARTICULAR PURPOSE AND NONINFRINGEMENT. IN NO EVENT SHALL THE AUTHORS OR COPYRIGHT HOLDERS BE LIABLE FOR ANY CLAIM, DAMAGES OR OTHER LIABILITY, WHETHER IN AN ACTION OF CONTRACT, TORT OR OTHERWISE, ARISING FROM, OUT OF OR IN CONNECTION WITH THE SOFTWARE OR THE USE OR OTHER DEALINGS IN THE SOFTWARE.

-----

This product includes OpenJDK.

The GNU General Public License (GPL)

Version 2, June 1991

Copyright (C) 1989, 1991 Free Software Foundation, Inc.  
51 Franklin Street, Fifth Floor, Boston, MA 02110-1301 USA

Everyone is permitted to copy and distribute verbatim copies of this license document, but changing it is not allowed.

Preamble

The licenses for most software are designed to take away your freedom to share and change it. By contrast, the GNU General Public License is intended to guarantee your freedom to share and change free software--to make sure the software is free for all its users. This General Public License applies to most of the Free Software Foundation's software and to any other program whose authors commit to using it. (Some other Free Software Foundation software is covered by the GNU Library General Public License instead.) You can apply it to your programs, too.

When we speak of free software, we are referring to freedom, not price. Our General Public Licenses are designed to make sure that you have the freedom to distribute copies of free software (and charge for this service if you wish), that you receive source code or can get it if you want it, that you can change the software or use pieces of it in new free programs; and that you know you can do these things.

To protect your rights, we need to make restrictions that forbid anyone to deny you these rights or to ask you to surrender the rights. These restrictions translate to certain responsibilities for you if you distribute copies of the software, or if you modify it.

For example, if you distribute copies of such a program, whether gratis or for a fee, you must give the recipients all the rights that you have. You must make sure that they, too, receive or can get the source code. And you must show them these terms so they know their rights.

We protect your rights with two steps: (1) copyright the software, and (2)

offer you this license which gives you legal permission to copy, distribute and/or modify the software.

Also, for each author's protection and ours, we want to make certain that everyone understands that there is no warranty for this free software. If the software is modified by someone else and passed on, we want its recipients to know that what they have is not the original, so that any problems introduced by others will not reflect on the original authors' reputations.

Finally, any free program is threatened constantly by software patents. We wish to avoid the danger that redistributors of a free program will individually obtain patent licenses, in effect making the program proprietary. To prevent this, we have made it clear that any patent must be licensed for everyone's free use or not licensed at all.

The precise terms and conditions for copying, distribution and modification follow.

#### TERMS AND CONDITIONS FOR COPYING, DISTRIBUTION AND MODIFICATION

0. This License applies to any program or other work which contains a notice placed by the copyright holder saying it may be distributed under the terms of this General Public License. The "Program", below, refers to any such program or work, and a "work based on the Program" means either the Program or any derivative work under copyright law: that is to say, a work containing the Program or a portion of it, either verbatim or with modifications and/or translated into another language. (Hereinafter, translation is included without limitation in the term "modification".) Each licensee is addressed as "you".

Activities other than copying, distribution and modification are not covered by this License; they are outside its scope. The act of running the Program is not restricted, and the output from the Program is covered only if its contents constitute a work based on the Program (independent of having been made by running the Program). Whether that is true depends on what the Program does.

1. You may copy and distribute verbatim copies of the Program's source code as you receive it, in any medium, provided that you conspicuously and appropriately publish on each copy an appropriate copyright notice and disclaimer of warranty; keep intact all the notices that refer to this License and to the absence of any warranty; and give any other recipients of the Program a copy of this License along with the Program.

You may charge a fee for the physical act of transferring a copy, and you may at your option offer warranty protection in exchange for a fee.

2. You may modify your copy or copies of the Program or any portion of it, thus forming a work based on the Program, and copy and distribute such modifications or work under the terms of Section 1 above, provided that you also meet all of these conditions:

- a) You must cause the modified files to carry prominent notices stating that you changed the files and the date of any change.
- b) You must cause any work that you distribute or publish, that in whole or in part contains or is derived from the Program or any part thereof, to be licensed as a whole at no charge to all third parties under the terms of this License.
- c) If the modified program normally reads commands interactively when run, you must cause it, when started running for such interactive use in the most ordinary way, to print or display an announcement including an appropriate copyright notice and a notice that there is no warranty (or else, saying that you provide a warranty) and that users may redistribute the program under these conditions, and telling the user how to view a copy of this License. (Exception: if the Program itself is interactive but does not normally print such an announcement, your work based on the Program is not required to print an announcement.)

These requirements apply to the modified work as a whole. If identifiable sections of that work are not derived from the Program, and can be reasonably considered independent and separate works in themselves, then this License, and its terms, do not apply to those sections when you distribute them as separate works. But when you distribute the same sections as part of a whole which is a work based on the Program, the distribution of the whole must be on the terms of this License, whose permissions for other licensees extend to the entire whole, and thus to each and every part regardless of who wrote it.



Thus, it is not the intent of this section to claim rights or contest your rights to work written entirely by you; rather, the intent is to exercise the right to control the distribution of derivative or collective works based on the Program.

In addition, mere aggregation of another work not based on the Program with the Program (or with a work based on the Program) on a volume of a storage or distribution medium does not bring the other work under the scope of this License.

3. You may copy and distribute the Program (or a work based on it, under Section 2) in object code or executable form under the terms of Sections 1 and 2 above provided that you also do one of the following:

- a) Accompany it with the complete corresponding machine-readable source code, which must be distributed under the terms of Sections 1 and 2 above on a medium customarily used for software interchange; or,
- b) Accompany it with a written offer, valid for at least three years, to give any third party, for a charge no more than your cost of physically performing source distribution, a complete machine-readable copy of the corresponding source code, to be distributed under the terms of Sections 1 and 2 above on a medium customarily used for software interchange; or,
- c) Accompany it with the information you received as to the offer to distribute corresponding source code. (This alternative is allowed only for noncommercial distribution and only if you received the program in object code or executable form with such an offer, in accord with Subsection b above.)

The source code for a work means the preferred form of the work for making modifications to it. For an executable work, complete source code means all the source code for all modules it contains, plus any associated interface definition files, plus the scripts used to control compilation and installation of the executable. However, as a special exception, the source code distributed need not include anything that is normally distributed (in either source or binary form) with the major components (compiler, kernel, and so on) of the operating system on which the executable runs, unless that component itself accompanies the executable.

If distribution of executable or object code is made by offering access to copy from a designated place, then offering equivalent access to copy the source code from the same place counts as distribution of the source code, even though third parties are not compelled to copy the source along with the object code.

4. You may not copy, modify, sublicense, or distribute the Program except as expressly provided under this License. Any attempt otherwise to copy, modify, sublicense or distribute the Program is void, and will automatically terminate your rights under this License. However, parties who have received copies, or rights, from you under this License will not have their licenses terminated so long as such parties remain in full compliance.

5. You are not required to accept this License, since you have not signed it. However, nothing else grants you permission to modify or distribute the Program or its derivative works. These actions are prohibited by law if you do not accept this License. Therefore, by modifying or distributing the Program (or any work based on the Program), you indicate your acceptance of this License to do so, and all its terms and conditions for copying, distributing or modifying the Program or works based on it.

6. Each time you redistribute the Program (or any work based on the Program), the recipient automatically receives a license from the original licensor to copy, distribute or modify the Program subject to these terms and conditions. You may not impose any further restrictions on the recipients' exercise of the rights granted herein. You are not responsible for enforcing compliance by third parties to this License.

7. If, as a consequence of a court judgment or allegation of patent infringement or for any other reason (not limited to patent issues), conditions are imposed on you (whether by court order, agreement or otherwise) that contradict the conditions of this License, they do not excuse you from the conditions of this License. If you cannot distribute so as to satisfy simultaneously your obligations under this License and any other pertinent obligations, then as a consequence you may not distribute the Program at all. For example, if a patent license would not permit royalty-free redistribution of the Program by all those who receive copies directly or indirectly through

you, then the only way you could satisfy both it and this License would be to refrain entirely from distribution of the Program.

If any portion of this section is held invalid or unenforceable under any particular circumstance, the balance of the section is intended to apply and the section as a whole is intended to apply in other circumstances.

It is not the purpose of this section to induce you to infringe any patents or other property right claims or to contest validity of any such claims; this section has the sole purpose of protecting the integrity of the free software distribution system, which is implemented by public license practices. Many people have made generous contributions to the wide range of software distributed through that system in reliance on consistent application of that system; it is up to the author/donor to decide if he or she is willing to distribute software through any other system and a licensee cannot impose that choice.

This section is intended to make thoroughly clear what is believed to be a consequence of the rest of this License.

8. If the distribution and/or use of the Program is restricted in certain countries either by patents or by copyrighted interfaces, the original copyright holder who places the Program under this License may add an explicit geographical distribution limitation excluding those countries, so that distribution is permitted only in or among countries not thus excluded. In such case, this License incorporates the limitation as if written in the body of this License.

9. The Free Software Foundation may publish revised and/or new versions of the General Public License from time to time. Such new versions will be similar in spirit to the present version, but may differ in detail to address new problems or concerns.

Each version is given a distinguishing version number. If the Program specifies a version number of this License which applies to it and "any later version", you have the option of following the terms and conditions either of that version or of any later version published by the Free Software Foundation. If the Program does not specify a version number of this License, you may choose any version ever published by the Free Software Foundation.

10. If you wish to incorporate parts of the Program into other free programs whose distribution conditions are different, write to the author to ask for permission. For software which is copyrighted by the Free Software Foundation, write to the Free Software Foundation; we sometimes make exceptions for this. Our decision will be guided by the two goals of preserving the free status of all derivatives of our free software and of promoting the sharing and reuse of software generally.

NO WARRANTY

11. BECAUSE THE PROGRAM IS LICENSED FREE OF CHARGE, THERE IS NO WARRANTY FOR THE PROGRAM, TO THE EXTENT PERMITTED BY APPLICABLE LAW. EXCEPT WHEN OTHERWISE STATED IN WRITING THE COPYRIGHT HOLDERS AND/OR OTHER PARTIES PROVIDE THE PROGRAM "AS IS" WITHOUT WARRANTY OF ANY KIND, EITHER EXPRESSED OR IMPLIED, INCLUDING, BUT NOT LIMITED TO, THE IMPLIED WARRANTIES OF MERCHANTABILITY AND FITNESS FOR A PARTICULAR PURPOSE. THE ENTIRE RISK AS TO THE QUALITY AND PERFORMANCE OF THE PROGRAM IS WITH YOU. SHOULD THE PROGRAM PROVE DEFECTIVE, YOU ASSUME THE COST OF ALL NECESSARY SERVICING, REPAIR OR CORRECTION.

12. IN NO EVENT UNLESS REQUIRED BY APPLICABLE LAW OR AGREED TO IN WRITING WILL ANY COPYRIGHT HOLDER, OR ANY OTHER PARTY WHO MAY MODIFY AND/OR REDISTRIBUTE THE PROGRAM AS PERMITTED ABOVE, BE LIABLE TO YOU FOR DAMAGES, INCLUDING ANY GENERAL, SPECIAL, INCIDENTAL OR CONSEQUENTIAL DAMAGES ARISING OUT OF THE USE OR INABILITY TO USE THE PROGRAM (INCLUDING BUT NOT LIMITED TO LOSS OF DATA OR DATA BEING RENDERED INACCURATE OR LOSSES SUSTAINED BY YOU OR THIRD PARTIES OR A FAILURE OF THE PROGRAM TO OPERATE WITH ANY OTHER PROGRAMS), EVEN IF SUCH HOLDER OR OTHER PARTY HAS BEEN ADVISED OF THE POSSIBILITY OF SUCH DAMAGES.

END OF TERMS AND CONDITIONS

How to Apply These Terms to Your New Programs

If you develop a new program, and you want it to be of the greatest possible use to the public, the best way to achieve this is to make it free software which everyone can redistribute and change under these terms.

To do so, attach the following notices to the program. It is safest to attach

them to the start of each source file to most effectively convey the exclusion of warranty; and each file should have at least the "copyright" line and a pointer to where the full notice is found.

One line to give the program's name and a brief idea of what it does.

Copyright (C) <year> <name of author>

This program is free software; you can redistribute it and/or modify it under the terms of the GNU General Public License as published by the Free Software Foundation; either version 2 of the License, or (at your option) any later version.

This program is distributed in the hope that it will be useful, but WITHOUT ANY WARRANTY; without even the implied warranty of MERCHANTABILITY or FITNESS FOR A PARTICULAR PURPOSE. See the GNU General Public License for more details.

You should have received a copy of the GNU General Public License along with this program; if not, write to the Free Software Foundation, Inc., 51 Franklin Street, Fifth Floor, Boston, MA 02110-1301 USA.

Also add information on how to contact you by electronic and paper mail.

If the program is interactive, make it output a short notice like this when it starts in an interactive mode:

Gnomovision version 69, Copyright (C) year name of author Gnomovision comes with ABSOLUTELY NO WARRANTY; for details type 'show w'. This is free software, and you are welcome to redistribute it under certain conditions; type 'show c' for details.

The hypothetical commands 'show w' and 'show c' should show the appropriate parts of the General Public License. Of course, the commands you use may be called something other than 'show w' and 'show c'; they could even be mouse-clicks or menu items--whatever suits your program.

You should also get your employer (if you work as a programmer) or your school, if any, to sign a "copyright disclaimer" for the program, if necessary. Here is a sample; alter the names:

Yoyodyne, Inc., hereby disclaims all copyright interest in the program 'Gnomovision' (which makes passes at compilers) written by James Hacker.

signature of Ty Coon, 1 April 1989

Ty Coon, President of Vice

This General Public License does not permit incorporating your program into proprietary programs. If your program is a subroutine library, you may consider it more useful to permit linking proprietary applications with the library. If this is what you want to do, use the GNU Library General Public License instead of this License.

#### "CLASSPATH" EXCEPTION TO THE GPL

Certain source files distributed by Oracle America and/or its affiliates are subject to the following clarification and special exception to the GPL, but only where Oracle has expressly included in the particular source file's header the words "Oracle designates this particular file as subject to the "Classpath" exception as provided by Oracle in the LICENSE file that accompanied this code."

Linking this library statically or dynamically with other modules is making a combined work based on this library. Thus, the terms and conditions of the GNU General Public License cover the whole combination.

As a special exception, the copyright holders of this library give you permission to link this library with independent modules to produce an executable, regardless of the license terms of these independent modules, and to copy and distribute the resulting executable under terms of your choice, provided that you also meet, for each linked independent module, the terms and conditions of the license of that module. An independent module is a module which is not derived from or based on this library. If you modify this library, you may extend this exception to your version of the library, but you are not obligated to do so. If you do not wish to do so, delete this exception statement from your version.

-----  
 This product includes tessdata.

Inc. Licensed under the Apache License, Version 2.0

-----

This product includes XMP Toolkit.  
 Copyright (c) 2020, Adobe  
 All rights reserved.

Redistribution and use in source and binary forms, with or without modification, are permitted provided that the following conditions are met:

1. Redistributions of source code must retain the above copyright notice, this list of conditions and the following disclaimer.
2. Redistributions in binary form must reproduce the above copyright notice, this list of conditions and the following disclaimer in the documentation and/or other materials provided with the distribution.
3. Neither the name of the copyright holder nor the names of its contributors may be used to endorse or promote products derived from this software without specific prior written permission.

THIS SOFTWARE IS PROVIDED BY THE COPYRIGHT HOLDERS AND CONTRIBUTORS "AS IS" AND ANY EXPRESS OR IMPLIED WARRANTIES, INCLUDING, BUT NOT LIMITED TO, THE IMPLIED WARRANTIES OF MERCHANTABILITY AND FITNESS FOR A PARTICULAR PURPOSE ARE DISCLAIMED. IN NO EVENT SHALL THE COPYRIGHT HOLDER OR CONTRIBUTORS BE LIABLE FOR ANY DIRECT, INDIRECT, INCIDENTAL, SPECIAL, EXEMPLARY, OR CONSEQUENTIAL DAMAGES (INCLUDING, BUT NOT LIMITED TO, PROCUREMENT OF SUBSTITUTE GOODS OR SERVICES; LOSS OF USE, DATA, OR PROFITS; OR BUSINESS INTERRUPTION) HOWEVER CAUSED AND ON ANY THEORY OF LIABILITY, WHETHER IN CONTRACT, STRICT LIABILITY, OR TORT (INCLUDING NEGLIGENCE OR OTHERWISE) ARISING IN ANY WAY OUT OF THE USE OF THIS SOFTWARE, EVEN IF ADVISED OF THE POSSIBILITY OF SUCH DAMAGE.

-----

This product includes openexr.

Copyright Contributors to the OpenEXR Project. All rights reserved.

Redistribution and use in source and binary forms, with or without modification, are permitted provided that the following conditions are met:

- \* Redistributions of source code must retain the above copyright notice, this list of conditions and the following disclaimer.
- \* Redistributions in binary form must reproduce the above copyright notice, this list of conditions and the following disclaimer in the documentation and/or other materials provided with the distribution.
- \* Neither the name of the copyright holder nor the names of its contributors may be used to endorse or promote products derived from this software without specific prior written permission.

THIS SOFTWARE IS PROVIDED BY THE COPYRIGHT HOLDERS AND CONTRIBUTORS "AS IS" AND ANY EXPRESS OR IMPLIED WARRANTIES, INCLUDING, BUT NOT LIMITED TO, THE IMPLIED WARRANTIES OF MERCHANTABILITY AND FITNESS FOR A PARTICULAR PURPOSE ARE DISCLAIMED. IN NO EVENT SHALL THE COPYRIGHT HOLDER OR CONTRIBUTORS BE LIABLE FOR ANY DIRECT, INDIRECT, INCIDENTAL, SPECIAL, EXEMPLARY, OR CONSEQUENTIAL DAMAGES (INCLUDING, BUT NOT LIMITED TO, PROCUREMENT OF SUBSTITUTE GOODS OR SERVICES; LOSS OF USE, DATA, OR PROFITS; OR BUSINESS INTERRUPTION) HOWEVER CAUSED AND ON ANY THEORY OF LIABILITY, WHETHER IN CONTRACT, STRICT LIABILITY, OR TORT (INCLUDING NEGLIGENCE OR OTHERWISE) ARISING IN ANY WAY OUT OF THE USE OF THIS SOFTWARE, EVEN IF ADVISED OF THE POSSIBILITY OF SUCH DAMAGE.

-----

This product includes Bonjour SDK.

Copyright (c) 2003-2004, Apple Computer, Inc. All rights reserved.

Redistribution and use in source and binary forms, with or without modification, are permitted provided that the following conditions are met:

1. Redistributions of source code must retain the above copyright notice, this list of conditions and the following disclaimer.
2. Redistributions in binary form must reproduce the above copyright notice, this list of conditions and the following disclaimer in the documentation and/or other materials provided with the distribution.
3. Neither the name of Apple Computer, Inc. ("Apple") nor the names of its contributors may be used to endorse or promote products derived from this software without specific prior written permission.

THIS SOFTWARE IS PROVIDED BY APPLE AND ITS CONTRIBUTORS "AS IS" AND ANY EXPRESS OR IMPLIED WARRANTIES, INCLUDING, BUT NOT LIMITED TO, THE IMPLIED WARRANTIES OF MERCHANTABILITY AND FITNESS FOR A PARTICULAR PURPOSE ARE DISCLAIMED. IN NO EVENT SHALL APPLE OR ITS CONTRIBUTORS BE LIABLE FOR ANY DIRECT, INDIRECT, INCIDENTAL, SPECIAL, EXEMPLARY, OR CONSEQUENTIAL DAMAGES (INCLUDING, BUT NOT LIMITED TO, PROCUREMENT OF SUBSTITUTE GOODS OR SERVICES; LOSS OF USE, DATA, OR PROFITS; OR BUSINESS INTERRUPTION) HOWEVER CAUSED AND ON ANY THEORY OF LIABILITY, WHETHER IN CONTRACT, STRICT LIABILITY, OR TORT (INCLUDING NEGLIGENCE OR OTHERWISE) ARISING IN ANY WAY OUT OF THE USE OF THIS SOFTWARE, EVEN IF ADVISED OF THE POSSIBILITY OF SUCH DAMAGE.

-----  
 This product includes Qt.

The software uses Qt, licensed under LGPL v3. The Qt Toolkit is Copyright (C) 2020 The Qt Company Ltd.

Portions of this software are copyright (C) 2006-2015 The FreeType Project (www.freetype.org). All rights reserved.

Copyright (C) 1991-2011, Thomas G. Lane, Guido Vollbeding.  
 This software is based in part on the work of the Independent JPEG Group.

Secure Hash Algorithm SHA-3 - brq\_endian  
 Copyright (c) 1998-2013, Brian Gladman, Worcester, UK. All rights reserved.

LICENSE TERMS

The redistribution and use of this software (with or without changes) is allowed without the payment of fees or royalties provided that:

1. source code distributions include the above copyright notice, this list of conditions and the following disclaimer;
2. binary distributions include the above copyright notice, this list of conditions and the following disclaimer in their documentation;
3. the name of the copyright holder is not used to endorse products built using this software without specific written permission.

DISCLAIMER

This software is provided 'as is' with no explicit or implied warranties in respect of its properties, including, but not limited to, correctness and/or fitness for purpose.

-----

## 1.3. Licenses

---

This software is protected against unauthorised use.

To purchase a license or a subscription, please visit <http://www.esko.com/store> or contact your Esko sales representative

### Local Licenses

For a local license or a subscription, you have to activate your product key on the machine that you run the software on. The Esko Plug-ins window is where you can activate a purchased license. Select **Help**

> **Esko > Esko Plug-ins** from the Illustrator menu. There is also a more advanced tool to manage your licenses and trials: the Esko Local License Manager. This application is installed in your Applications folder (Mac) or see **Start > Programs > Esko > Local License Manager > Manage Local Licenses...** (PC).

### **Network Licenses**

For a network license you have to activate your product key on a central machine, the license server, in the Esko Server License Manager application.

Make sure to configure the license server in Adobe Illustrator by selecting **Help > Esko > Esko Plug-ins ....** Select the Network License Setup button at the bottom of the Esko Plug-ins dialog.

## 2. Getting Started with Studio Essentials

---

### 2.1. Tutorial: Folding a box

---

In this tutorial, we will assign cut and crease properties to die lines, fold it into a box and save it as a ARD file. We will then use this ARD file on the graphic design of the box to get a 3D Pack shot as shown below.



1. If you didn't download the sample files already, you can download a ZIP containing all files from this location: <https://docs.esko.com/docs/en-us/studioessentials/16/otherdocs/StudioTutorials.zip>.
2. From the `Expert Box` folder, open the file `EXPERT_Design.ai`  
This file contains all die lines, but at this moment not recognized as such.
3. Assign the correct Crease and Cut properties to the die lines
  - a) Open **Window > Esko > Studio Toolkit for Boxes > Show Fold Window** or use the shortcut **Cmd +Alt+1**(Mac) or **Ctrl+Alt+1**(Windows).
  - b) In Illustrator's Layers menu, select all objects in the sublayer "creaselines" and click the **Crease** swatch in the **Fold** window.
  - c) In Illustrator's Layers menu, select all objects in the sublayer "cutlines" and click the **Cut** swatch in the **Fold** window.

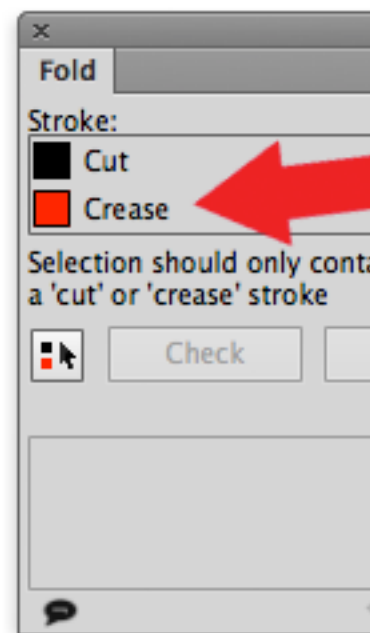
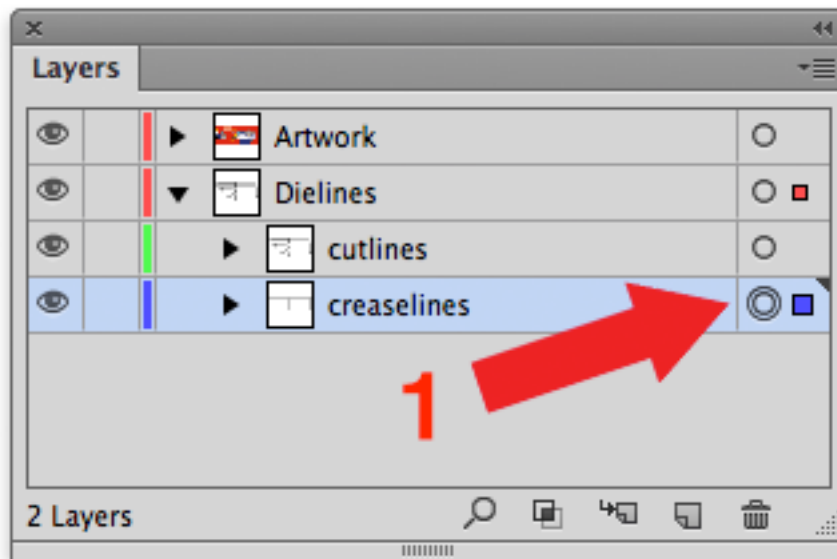

4. Click the **Select all Cuts and Creases** button , and click the **Check** button to check the die for inaccuracies.  
You will get a warning that double lines were found. Click **Yes** to let Studio fix it automatically.
5. With all Cut and Crease lines still selected, click **Fold** to open the Fold window.



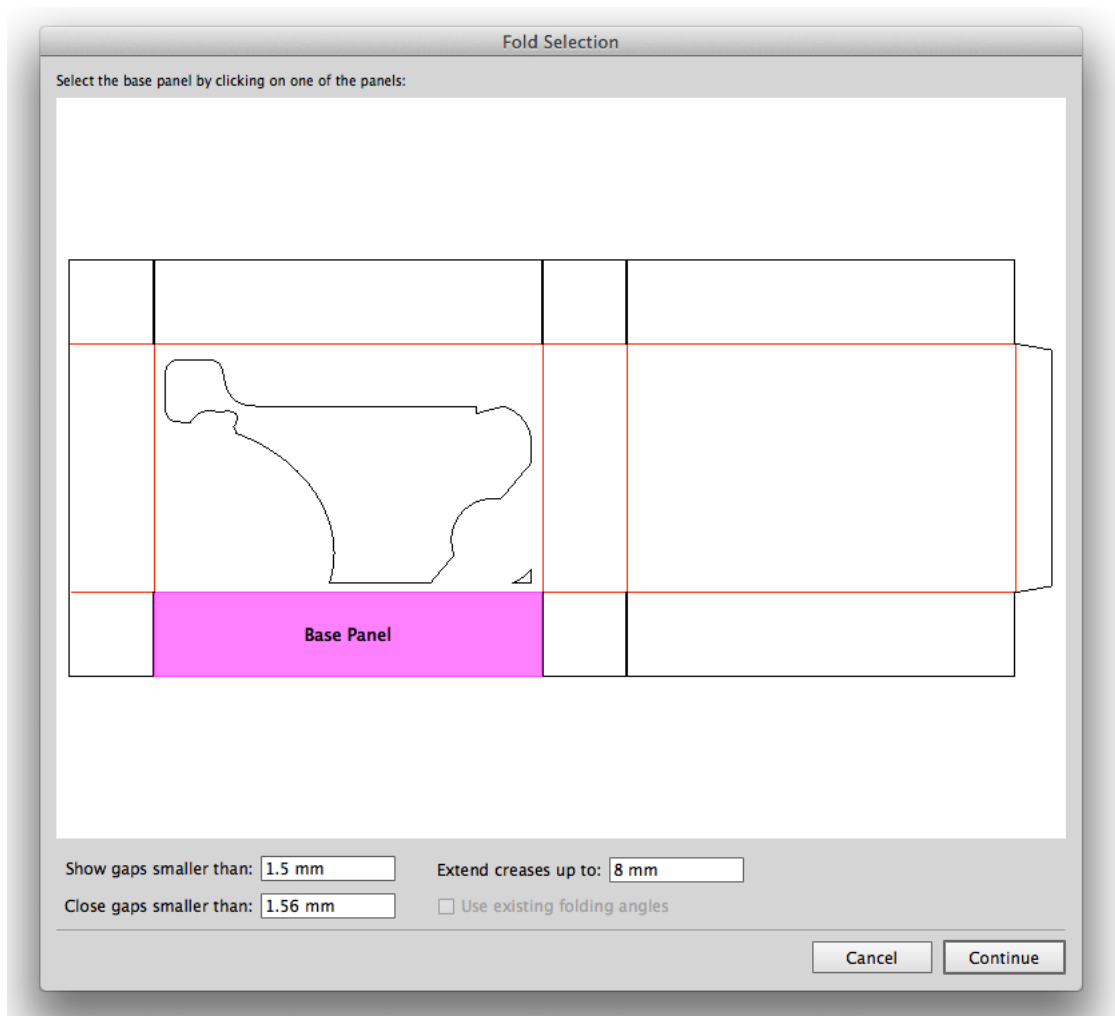

- a) Click in the bottom left panel (see image above) to set it as **Base Panel** and click **Continue**
- b) Select **E Flute** as board, and click **Continue**
- c) Click **Select All Fold Lines** and set the **Folding Angle** to 90 degrees. You now already get a 3D preview of the box.

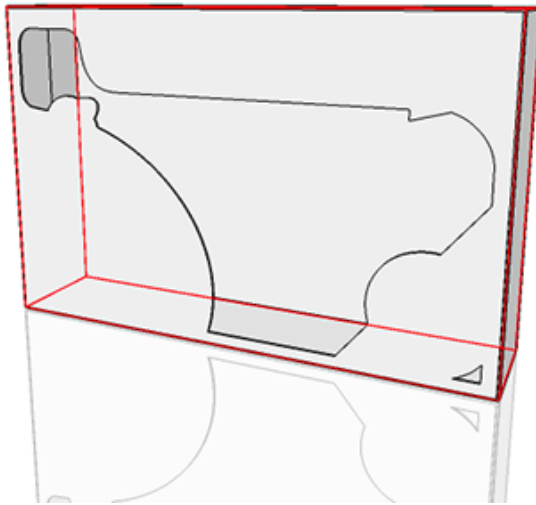

- d) Click **Save As** and save your box as an ARD file.
- e) When asked if you want to place the ARD file in the current document, click **Yes**
- 6. Open the Studio window: choose **Window > Esko > Studio Designer > Show Studio** or use the shortcut **Cmd+Alt+4** (Mac) or **Ctrl+Alt+4** (Windows).

You immediately get a 3D preview of your box. Click and drag to rotate it to inspect all sides.

- 7. We will now add two finishing operations: a liner, and a gold foil.
  - a) Open the Finishing Operations panel by choosing **Window > Esko > Studio Visualizer > Show Finishing Operations**
  - b) Click the **Add Operation** button 
  - c) Choose **Esko Standard Library > Board Liners > High gloss coated liner** and click **OK**
  - d) Select **Apply full coverage** to apply the liner on the complete design, and click **OK**
  - e) In the **Finishing Operations** palette, double-click the yellow spot color.

This yellow spot color was used by the designer to indicate where the gold foil needs to be applied. We will convert this spot color into a finishing operation.

- f) Choose **Esko Standard Library > Foils > Gold Foil Block (hot stamped)** and click **OK** twice

The Finishing Operations palette should now look like this:

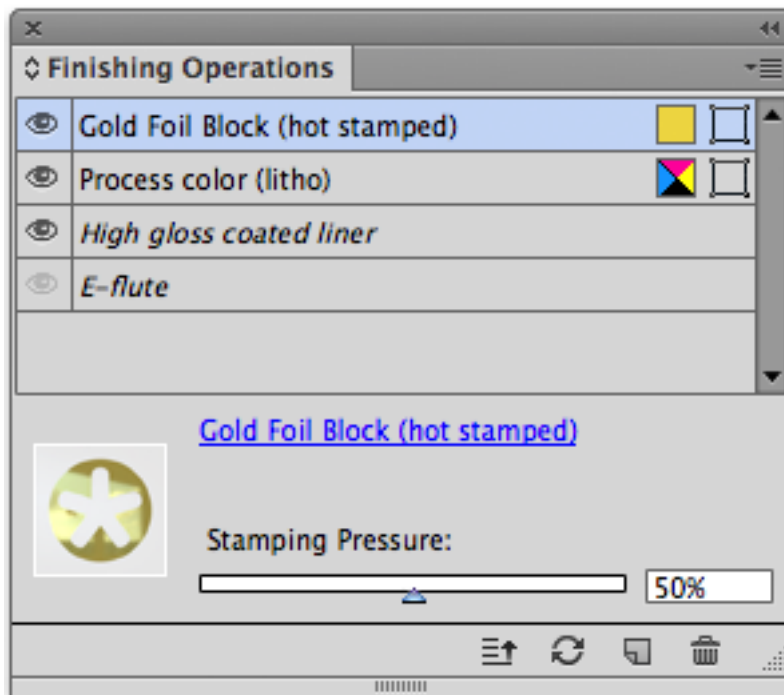

- g) In the Scene Presets in the Studio window, choose **Visualizer Office**
  - This will change the lighting environment and switch to **Visualizer Quality**. Once the Studio window is refreshed, you will get a realistic preview of the box, including the gold foil. Rotate the box to inspect it.
- 8. We will now export a TIFF packshot of the box
  - a) Rotate (by clicking and dragging) and zoom (using the Zoom slider) to position the box the way you want it.
  - b) In the Studio window flyout menu, choose **Export**
  - c) Set **File Type** to TIFF Image, and click **Save As...** to save a TIFF packshot you can share with your clients.

## 2.2. Tutorial: revolve a path and add labels

---

In this tutorial, we will create a bottle by revolving a profile path. We will add labels to it, and apply a graphic design on these labels. We will export this as a collada file to be previewed in one of the available Viewers.



1. If you didn't download the sample files already, you can download a ZIP containing all files from this location: <https://docs.esko.com/docs/en-us/studioessentials/16/otherdocs/StudioTutorials.zip>.
2. From the `SPEED Bottle` folder, open the `Bottle_Outline.ai` file  
This file contains two paths, representing the contours of a bottle and its cap.
3. Open the Studio window: choose **Window > Esko > Studio Designer > Show Studio** or use the shortcut **Cmd+Alt+4** (Mac) or **Ctrl+Alt+4** (Windows).  
Since there is no Structural Design file in this document, the Studio window is empty.
4. Select both paths, and choose **Revolve Path in Toolkit** from the fly-out menu of the Studio Window.  
The **Studio Toolkit** application will open.
5. For the **Axis**, select the leftmost option and click **OK**  
The bottle has two parts: the cap and the bottle.

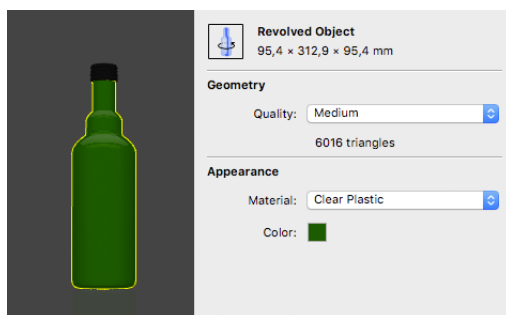

6. In the **Appearance** section, set the material and color of your bottle as you prefer. We used a black matt plastic cap and a green clear plastic bottle.
7. Add a **Front label** by selecting the bottle, clicking **Add Label** and selecting **Front Label**. Set its dimensions to 100 mm width, 115 mm height and 40 mm Base.
8. Add a **Back label** by selecting the bottle, clicking **Add Label** and selecting **Back Label**. Set its dimensions to 70 mm width, 100 mm height and 45 mm Base.
9. Save the bottle as a Collada file.

- a) Click **Save As**
- b) Choose a name and location for the file, and click **Save**
- c) Close Studio Toolkit.

10. Open the file `SpeedRound_Front.ai` from the `SPEED Bottle` folder.

11. Click **Place a Structural Design file** in the Studio Window and select the Collada file you saved. The Collada file contains two printable parts. Choose the Front Label.

You immediately get a 3D preview of your bottle. Click and drag to rotate it to inspect all sides. You can see the back label is still empty.

12. Repeat the three previous steps using the `SpeedRound_Back.ai` file, but this time select the **Back Label** printable part

You now get a 3D preview of your bottle with both labels. Click and drag to rotate it to inspect all sides. Double-click a label to select the corresponding Illustrator document.

13. In the fly-out menu of the Studio window, choose **Scene Settings**, and select the **Visualizer Light Photo Studio** Scene Preset. Click **OK**

This will change the lighting environment and switch to **Visualizer Quality**. Once the Studio window is refreshed, you will get a realistic preview of the bottle, including the transparent plastic. Rotate the bottle to inspect it.

14. We will now add a "die cut" finishing operation to apply rounded corners on the front label.

- a) Go to the `SpeedRound_Front.ai` document.
- b) In Illustrator's Layers palette, select the compound path in the "RoundedCorners" layer. Since this is a Compound path, you first have to release it by using the shortcut **Cmd+Alt+Shift+8** (Mac) or **Ctrl+Alt+Shift+8** (Windows). Only select the rectangle with rounded corners
- c) In the fly-out menu of the Studio Window, select **Send Path to Toolkit**

The bottle will be opened in Studio Toolkit, and the path will be selected as Die-cut path.

- d) In Studio Toolkit, select **File > Save**
- e) Return to Adobe Illustrator.

You will get a message that the Structural Design file was changed. Click **Update**. You will see the label with rounded corners.



15. Save the design as a Collada file to be previewed in one of the available Viewers.

- a) In the Studio window flyout menu, choose **Export**
- b) Set **File Type** to Collada File, and click **Export...** to save the file as a collada file.



**Note:** Unlike the first collada file we saved in Studio Toolkit, which contained only the structure (bottle and labels without graphics), this second collada file is just for viewing.

- 16. Open the file in the **Studio Viewer** application.

The Studio Viewer is a free application that is installed automatically when installing Studio, and can also be downloaded from the Esko website <http://www.esko.com>

You can also use the free mobile app, available from the App store or Google Play, or open the file in the WebCenter Viewer.

## 2.3. Tutorial: combining shapes & working with Scenes

In this tutorial we will create a composition of different shapes, each with their artwork. We will then use the same graphics in different scenes.

- 1. If you didn't download the sample files already, you can download a ZIP containing all files from this location: <https://docs.esko.com/docs/en-us/studioessentials/16/otherdocs/StudioTutorials.zip>.
- 2. Open **Studio Toolkit**
- 3.

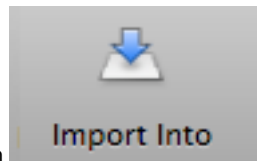

Click the **Import Into...** button and select the **Tray.ard** file from the **Color > Structure** folder. Repeat for **Pouch.zae**.

The pouch will be placed next to the tray.

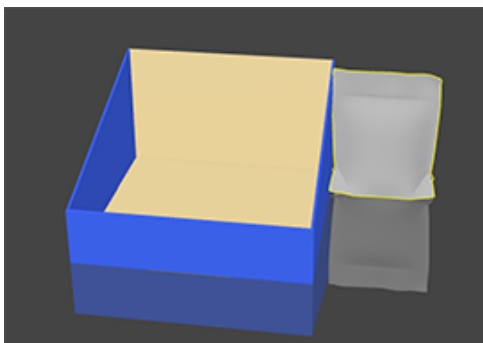

- 4. Change the view to **Top**, so you get a top view of the two objects.

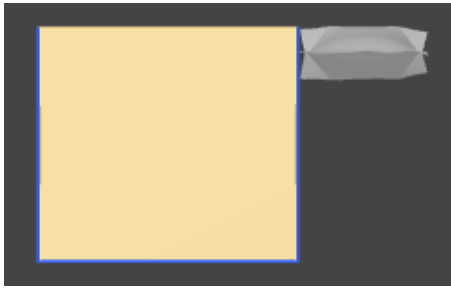

5.



Select the **Transform** tool

6. Click and drag the center point of the pouch to move it to the upper left corner of the tray.

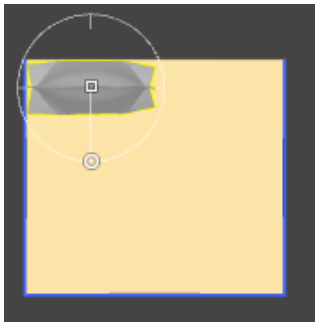

Make sure the pouch is NOT touching the back side or side panel of the tray.



**Note:** You might notice the pouch snapping to the tray when you move it too close, indicated by the tray lighting up. This "snap" function, based on the bounding box of the objects, can be very useful when aligning objects next to each other, but since we are positioning inside an object, this is not what we want. In this case, it can be easier to disable snapping, by deselecting the check box in the menu bar.

7. Switch back to **Perspective** view.

8. Select **Edit > Lift Up**. You will notice the **Distance from Floor** value changing to 1.5 mm, which is the thickness of the cartboard of the tray.

If your pouch jumps on top of the back panel of the tray, your pouch was touching the back panel. Undo the **Lift Up** using **cmd - Z** (Mac) or **Ctrl - Z** (Windows) and adjust the position of your pouch.

9.



Click the **Repeat** button and apply a repeat of 2 times along the X axis, 4 times along the Z axis.

You now have a tray with 8 pouches in it. Drag to change the camera viewpoint to inspect the tray.

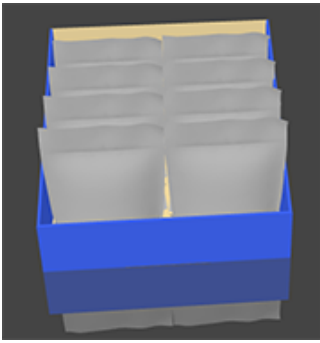

10. Select **File > Save** and enter a name for the Collada file.



**Note:** In one of the next steps, we will also use the Collada file of a more complex composition based on this tray. You can create this composition yourself by following the additional steps described in [Additional steps to create the complete display](#) on page 46

11. In Adobe Illustrator, open the `Pouch.ai` file from the `Color` folder.

12. Open the Studio window: choose **Window > Esko > Studio Designer > Show Studio** or use the shortcut **Cmd+Alt+4** (Mac) or **Ctrl+Alt+4** (Windows).

Since there is no Structural Design file in this document, the Studio window is empty.

13. Click **Place a Structural Design file** in the Studio Window and select the `Pouch.zae`.

You immediately get a 3D preview of your pouch. Click and drag to rotate it to inspect all sides.

14. Repeat the three previous steps using the `Tray.ai` file, but this time use the `Tray.ard` file

15. In the **Scene** dropdown in the **Studio** palette, select **Load Scene**, and select the file containing the tray and pouches you created earlier.

You now get a 3D preview of your tray and pouches. Click and drag to rotate it to inspect all sides.



16. You can now use the Studio window to navigate through the Adobe Illustrator documents used in the design.

- Double-click one of the parts of a pouch to select the corresponding Illustrator document, and zoom in on that specific part.



- Double-click one of the panels of the tray to select the corresponding Illustrator document, and zoom in on that specific panel.
- Hold the **Cmd** (Mac) or **Ctrl** (Windows) key and drag on an area you want to inspect. The corresponding Illustrator document will be selected, zooming in on the corresponding area in the file.

17. In the **Scene** dropdown in the **Studio** palette, select **Load Scene**, and select the `Display_Composition.zae` file from the `Color > Structure` folder. If you did the extra steps described in [Additional steps to create the complete display](#) on page 46, you can load the file you saved there instead.

You now will get a preview of the same tray and pouches in a larger, more complicated display.



You can navigate through it the same way as described above. You can add graphics to the other parts of the display, either by opening the graphics and applying the Structural Design file to it, or by double-clicking an empty part, and choose **New** to start from scratch.

18. Unlike the tray and pouches we saved earlier, this complex composition actually contains two different pouches. This will allow us to apply a different design to them.
- a) In Adobe Illustrator, open the `Pouch_alternative.ai` file from the `Color` folder.
  - b) In the **Scene** dropdown of the Studio Window (which is now empty, since no Structural Design is used in the newly opened file), reselect the `Display_Composition.zae` scene
  - c) Select one of the pouches on the left side.
  - d) In the **Front Artwork** dropdown, select **Place in Current Document**

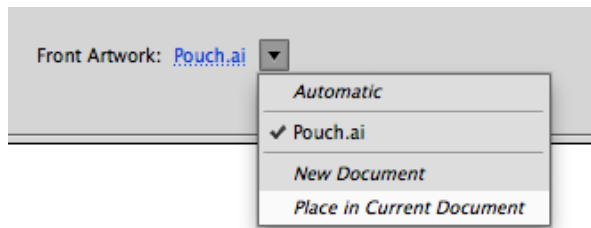

All pouches on the left hand side will now show the design of the alternative version.

You might notice the alternative pouch has a diecut operation set. Switch the **Scene Settings** to "Visualizer Office" to get a realistic preview, including the cutouts in the pouch.



### 2.3.1. Additional steps to create the complete display

After creating the tray with pouches described in [Tutorial: combining shapes & working with Scenes](#) on page 42, you can use these steps to continue and create the full display yourself.

1. If you don't have it open anymore, open the file you created earlier, containing the tray and the 8 pouches, in Studio Toolkit.

2.

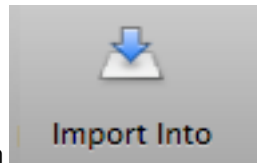

Click the **Import Into...** button and select the **Display\_Divider.ard** file from the **Color > Structure** folder.

3. With the Divider still selected, choose **Edit > Inverse Selection** to deselect the divider, and select the tray and all pouches.

4.



Select the **Transform** tool

5. Change the **Distance from Floor** value to 100 mm, which is the height of the divider

6. Click and drag the center point of the selection to position it on the divider.

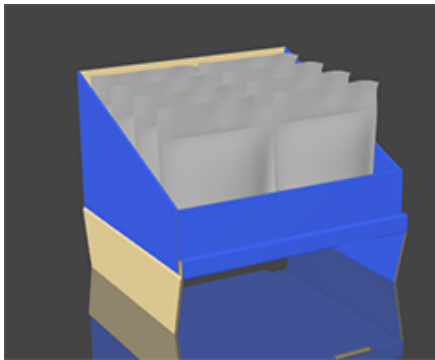

**Note:** It can be easier to align the objects by switching temporarily to Top View.

7.

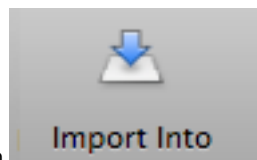

Click the **Import Into...** button and select the **Display\_Base.ard** file from the **Color > Structure** folder.

8. With the Base still selected, choose **Edit > Inverse Selection** to deselect the Base, and select the divider, tray and all pouches.

9.



Select the **Transform** tool and select  **Move** or use its shortcut **M**

This will allow moving and aligning the selection over one axis at a time.

10. First, click and drag outside of the selection to change the camera viewpoint, so you see the back side of the design.

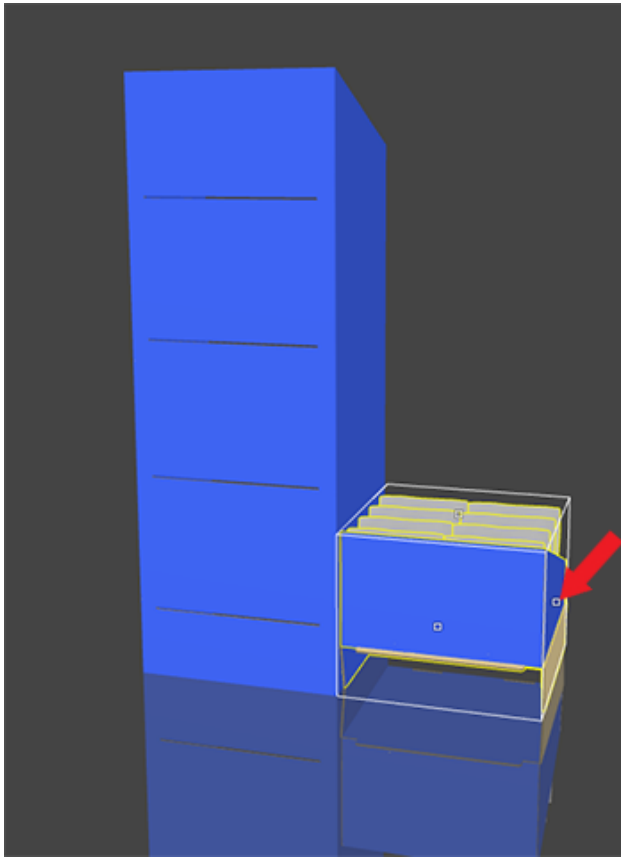

- 11.** Click and drag the handle on the right side (indicated in the image above by the red arrow) and move the divider, tray and pouches centered in the base.
- 12.** Click and drag the handle at the front of the selection to move the selection forward a bit, and use the handle at the top to move it upwards. The result should be that the cartboard extension on the divider fits neatly in the slot in the back of the base.

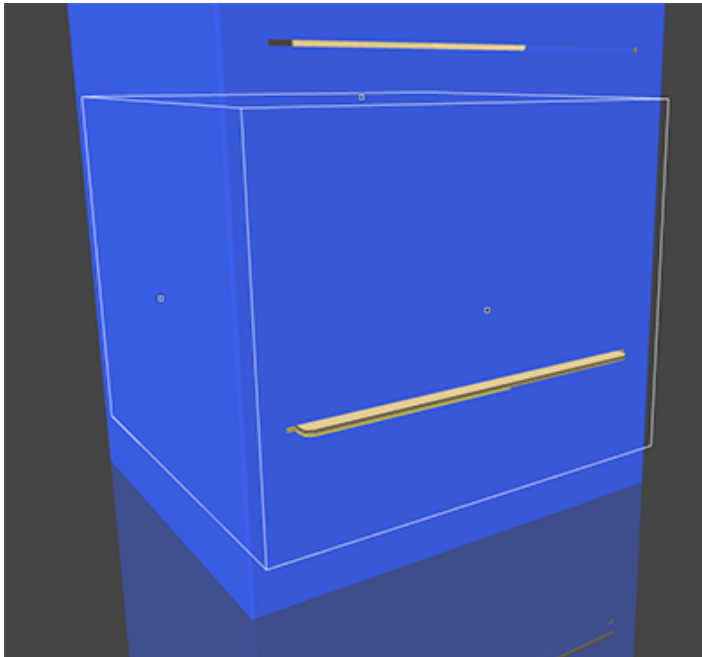

13.



Click the **Repeat** button and apply a repeat of 4 times along the Y axis.

You now have 4 sets of divider, tray and pouches on top of each other. You can however see the distance between the different sets is too big.

14. Change the **Gap** value until the dividers line up with the slots in the back of the base. The value you need is -57mm. Click **Done**

15. Choose **File > Save As** to save the complete display as a collada file.

## 2.4. eLearning

---

Next to the Tutorials and the information in this documentation, Esko also provides **eLearning** content.

To access the eLearning content, go to <https://www.esko.com/en/support/blendedlearning>

To access these courses you need to log in with your Esko ID.

## 3. Step 1: Getting the 3D shape

---

### 3.1. About Structural Design files and Printable Parts

---

The base of the 3D preview in Studio is the 3D model, saved in a **Structural Design** file. A Structural Design file should contain 2D information and 3D information.

#### Structural Design Files and Printable parts

A Structural Design file describes a 3D scene, of which at least one part can be printed: the **Printable Part**. Different types of Structural Design files can be used:

- A **3D Sheet** is a 3D representation of a simple sheet, that can be used e.g. to visualize finishing operations in Visualizer quality. See [Create a 3D Sheet](#) on page 70
- an **ARD** Structural Design file, created in ArtiosCAD or Studio Toolkit for Boxes, mainly used for boxes. For an ARD file, the entire box is one single printable part.
- .bag files created in older versions of Studio Toolkit for Flexibles. These .bag files are also one printable part.
- **Collada** files, containing one or more 3D shapes with at least one printable part (.dae or .zae files). For Collada files, a printable part is an Esko extension. A collada file can contain one or more printable parts, such as a flexible bag, one or more labels on a bottle, a shrink sleeve, .... A Collada file can also contain non-printable parts, such as the glass bottle itself. Collada files with one or more printable parts can be created in ArtiosCAD or Studio Toolkit.



**Note:** More technical information on Printable Parts in Collada files can be found in the white paper you can find in the Studio documentation: <https://www.esko.com/en/support/product?id=Studio>

- an **ACD** Canvas file, created in ArtiosCAD, also contains one or more 3D Shapes with one or more printable parts.

#### Esko Data Exchange

To bring the Structural Design and the graphic design together, a Structural Design file can be placed or opened. You can place Structural Design files in Illustrator with the **Esko Data Exchange** plug-in, which can be downloaded for free from the Esko website and which is also installed when installing Studio Essentials. With the Esko Data Exchange plug-in the 2D lines (such as cut and crease lines) can be aligned with the graphics. You can find the Esko Data Exchange documentation at <https://www.esko.com/en/Support/Product?id=Esko%20Data%20Exchange%20for%20Adobe%20Illustrator> or open it from within Illustrator, by choosing **Help > Esko > Esko Help > Esko Data Exchange**.



**Note:**

You can also load a Structural Design file as an extra scene in the Studio window. Each part of the scene can get its graphics from another illustrator document. See [Scenes and Multiple Documents](#) on page 151

### ARD Structural Design files

ARD files are the native files of ArtiosCAD, which is a professional tool to design board-based structures. An ARD file contain all the cut and crease lines, and sometimes also the folding angles that describe how the package is folded into its final shape. The Structural Design file does not contain the graphics, only the structural lines.

You can get an ARD file:

- from **ArtiosCAD**
- by creating a box in Adobe Illustrator. See [Create a box](#) on page 71

### Collada files

Collada is an open and public file format to describe 3D shapes. In case a Collada file is placed, a check is performed to see if the Collada file has a **Printable Part** defined. A printable part is an Esko extension to the Collada format.

You can get a Collada file:

- from an external 3D modelling application. You might need to add a printable part, e.g. by adding a label in Studio Toolkit. See [Obtain a 3D shape to import in Studio Toolkit](#) on page 53 and [Add a label to an existing shape](#)
- from ArtiosCAD
- by revolving a shape in Adobe Illustrator or Studio Toolkit. See [Creating a revolved shape with labels](#) on page 95
- by creating a shape in Studio Toolkit. See [The Studio Toolkit Application](#) on page 51

### ACD Structural Design files

ACD files - ArtiosCad Canvas Design Document - is a native ArtiosCAD file. A Canvas is a design workspace made of multiple separate pieces called **parts**. These parts can be ARD files that represent e.g. a display, but can also be layouts or non-production data such as a picture of the final package. In Studio, the **production** parts of an ACD file can be placed in the Illustrator document, and used as **Printable Part**. The ACD file itself can also be loaded as a scene.



**Note:** Copies of the 3D Shape in ArtiosCAD will share the same printable part. In order to apply different graphics on multiple shapes coming from the same ARD file, you should import this ARD file multiple times into the canvas file. That way, each shape will have its own printable part.

## 3.1.1. The Studio Toolkit Application

The **Studio Toolkit** application is a standalone application allowing to import, edit and create 3D objects, and save the object(s) as Collada file.

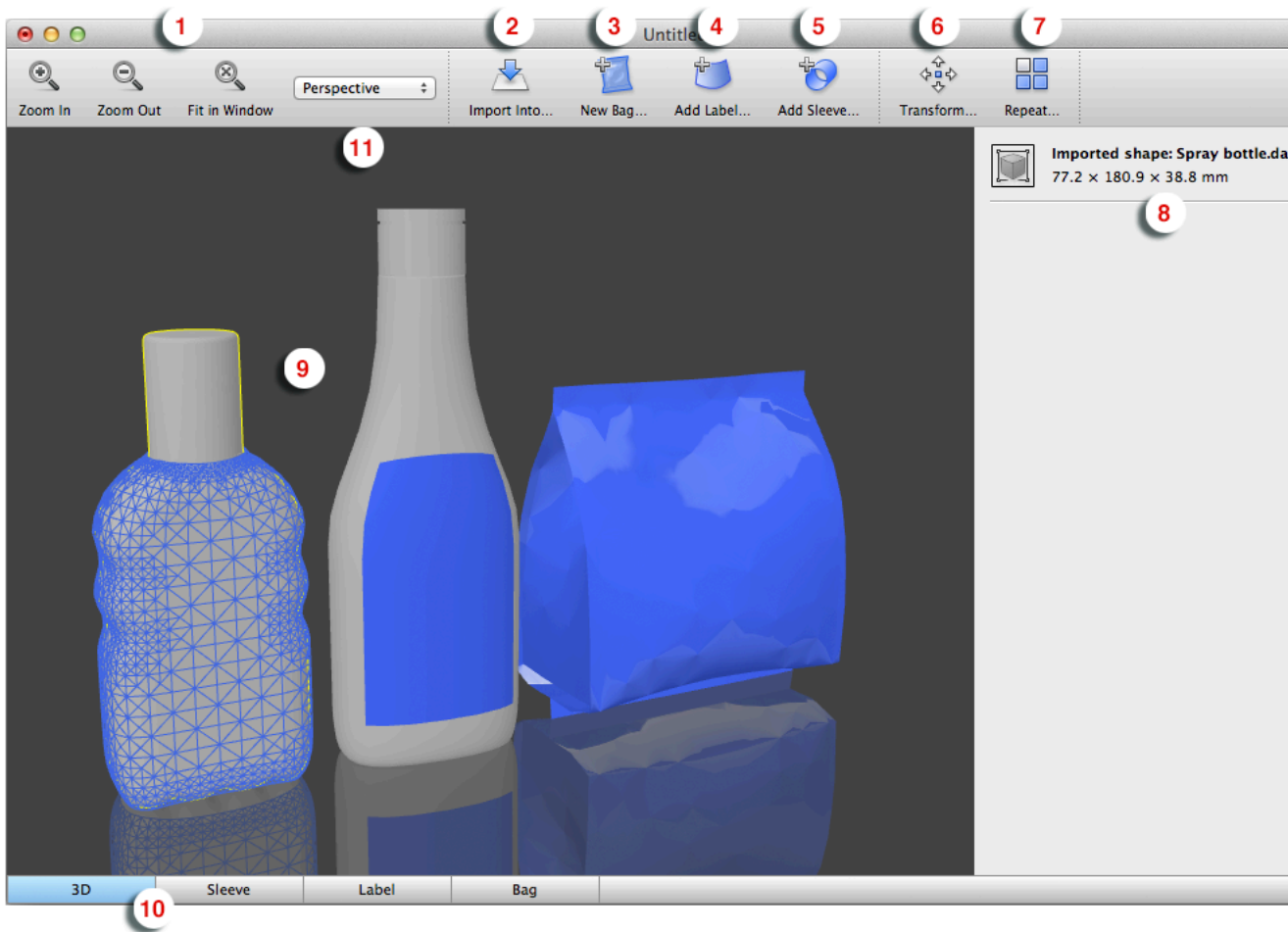

1. The **Zoom** buttons, allowing to change the zoom factor of the preview window. You can also change the camera view point: see [Changing the View](#) on page 58
2. **Import Into** allows to import 3D or image files. See [Importing Shapes, Images or Paths](#) on page 53
3. The **New Bag** tool. See [Create a flexible bag](#)
4. The **Add Sleeve** tool. See [3D workflow for Shrink Sleeve Package](#)
5. The **Add Label** tool. See [Add a label to an existing shape](#)
6. The **Transform** tool. See [Transform the selected 3D shape\(s\)](#) on page 59
7. The **Repeat** button. See [Repeat](#) on page 65
8. The **Settings** panel, allowing to change or view the parameters on the selected object
9. the **Preview** panel
10. The different **Tab**s. See [Tabs](#) on page 67
11. When performing some specific functions (such as Transform, ...), a settings bar is added underneath the Toolbar.

### Saving and opening Collada files

When saving a file from **Studio Toolkit**, the file is saved as a Collada file, containing the shape and all printable parts.



This means the file can be opened by any application that is capable of handling Collada files, such as Studio Essentials in Adobe Illustrator.

However, the Collada files saved by Studio Toolkit also contains native Studio Toolkit information, allowing to reopen the file in Studio Toolkit, maintaining its editability, the active tab, zoom and view factor, etc.



**Note:** When dropping a Collada file onto the Studio Toolkit application, Studio Toolkit will determine if it is a Collada file saved in Studio Toolkit or not. A native Studio Toolkit Collada file will be opened, a regular Collada file will be imported.

## Importing Shapes, Images or Paths

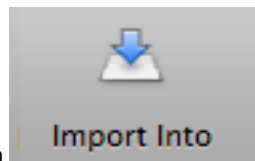

Using the **Import Into** button you can import a 3D shape into your open scene. If you already have a 3D object in your scene, the newly imported 3D shape will be placed next to it.

For more info on how to obtain a 3D file, see [Obtain a 3D shape to import in Studio Toolkit](#) on page 53

When importing a Collada file or an ArtiosCAD ARD file, any printable parts from this file will be preserved when saving to a Collada file. You can't import ArtiosCAD ACD files.



**Note:** Collada files saved by Studio Toolkit can also be opened instead of imported. In that case, the file will be reopened as it was saved, with the same active tab, zoom and view, and maintaining full editability. See [Saving and opening Collada files](#) on page 52

You can also use the **Import Into** button to import an image (JPG or PNG) in a 2D tab (e.g. the "Sleeve" tab), to get a preview of this image on the corresponding 3D object. See [Using graphic files](#) on page 54



**Note:** Studio Toolkit can not import .bag files. If you need to compose flexible bags or boxes saved as .bag files, we suggest you convert these to Collada files in Studio Designer first.

You can also import **Paths** to use as a Die Cut Path on a Front, Back or Wrap Around label, or you can use a path to create a revolved shape. See [Using a Path as a Die Cut](#) on page 91 and [Revolve a profile and Add Labels in Studio Toolkit](#) on page 107

## Obtain a 3D shape to import in Studio Toolkit

There are several ways to obtain a 3D file :

- You can get a shape on Esko's online Shapes store
- You could hire a 3D artist to make the shape with a 3D modeling tool, such as Cinema 4D, 3DS Max, Maya or Strata. If you are experienced with these tools, you could do it yourself.
- Contact the mold-designer and ask him for a digital file of the 3D shape. Studio Toolkit supports Collada, OBJ, STL, 3DS, OFF, DXF and FBX files. BLEND files lower than 2.80 are also supported.
- If you have a physical sample of the object, you can use a tabletop 3D laser scanner. See [www.nextengine.com](http://www.nextengine.com) for an example of such a scanner. This device can output .obj files.
- If the object is a round shape, you can revolve a profile to create it yourself. See [Creating a revolved shape with labels](#) on page 95
- You can import an ArtiosCAD ARD file into Studio Toolkit. ArtiosCAD ACD files are not supported.

The format needs to be Collada (.dae or .dae), ARD, OBJ, STL, 3DS, BLEND lower than 2.80, OFF, DXF or FBX.

Collada stands for COLLABorative Design Activity for establishing an interchange file format for interactive 3D applications)

These 3D files might not have a printable part at this stage, you can add that yourself in the Studio Toolkit application.



**Note:** Currently textures are discarded when importing a 3D shape.

### Using graphic files

In Studio Toolkit you can import graphic files to get a preview of the result, and to assist in positioning e.g. the overlap. You can also use it to place a technical drawing on the sleeve.

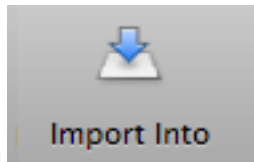

Using the **Import Into** button you can import an RGB JPEG or PNG file.

- If a 2D tab is selected, the image will be imported in that tab
- If an object is selected in the 3D tab, the image will be imported in the corresponding 2D tab, and this 2D tab will become active

By default, the image will be aligned with the bottom left corner of the image on the bottom left corner of the printable part. You can move the graphic by clicking and dragging the border. The border (left, right, top or bottom) or corner you clicked, will become magnetic, and snap to the borders and folding lines of the 2D shape, allowing easy alignment.

This magnetism is shown using a thick blue line.

The 3D tab will show a 3D representation of the file with the corresponding graphics on it.

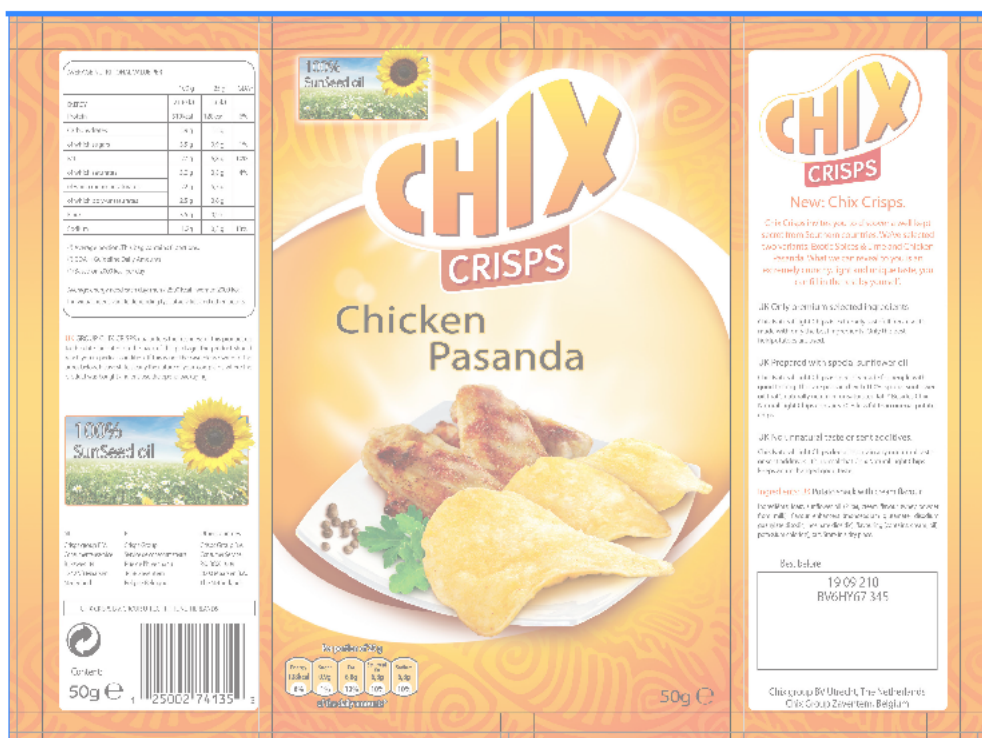

**Save Graphics Preview as PNG...**

In certain cases, you may want to apply artwork from within Adobe Illustrator onto your 3D shape in Studio Toolkit.

- If you want to get a preview of your artwork on a shape you use in a composition.
- If you want to place a technical drawing on your shape, e.g. in case of a flexible bag, to check the position of your seams

For this purpose, you can save a graphics preview file as a .png file from within the Studio window.

1. If your Structural Design file has multiple printable parts, select the printable part for which you want to export a graphics preview in the Studio window
2. In the fly-out menu of the Studio window, select **Save Graphics Preview as PNG...**
3. Select a file name and location, and click **Save**



## Paths

You can import paths created in Adobe Illustrator directly into Studio Toolkit.

1. Select the path in Adobe Illustrator
2. To view the Studio window, choose **Window > Esko > Studio Designer > Show Studio** or use the shortcut **Cmd+Alt+4** (Mac) or **Ctrl+Alt+4** (Windows).
3. From the fly-out menu in the Studio window, select **Send Path to Toolkit**.

This will create a closed path object in the 2D tab of Studio Toolkit.

Paths can be used to define the die cut shape of a **Front Label**, **Back Label** or **Wrap Around Label**. See [Using a Path as a Die Cut](#) on page 91



**Note:** You can also send a path from Adobe Illustrator to Studio Toolkit to create a revolved shape. See [Revolve a profile and Add Labels in Studio Toolkit](#) on page 107

## Preview Color

For each imported ARD file, you can define the **Preview Color**.

Simply select the part you want, and click the **Preview Color**. You can choose one of the 8 predefined colors.



This can help to distinguish between the different parts, e.g. when building a scene. See also [Combining shapes in Studio Toolkit](#) on page 156

Multiple instances of the same part will share the same preview color.



**Note:** The **Preview Color** is purely a visual aid in Studio Toolkit, and does not become part of the 3D model. The Preview Color is only visible when reopening the Collada file in Studio Toolkit.

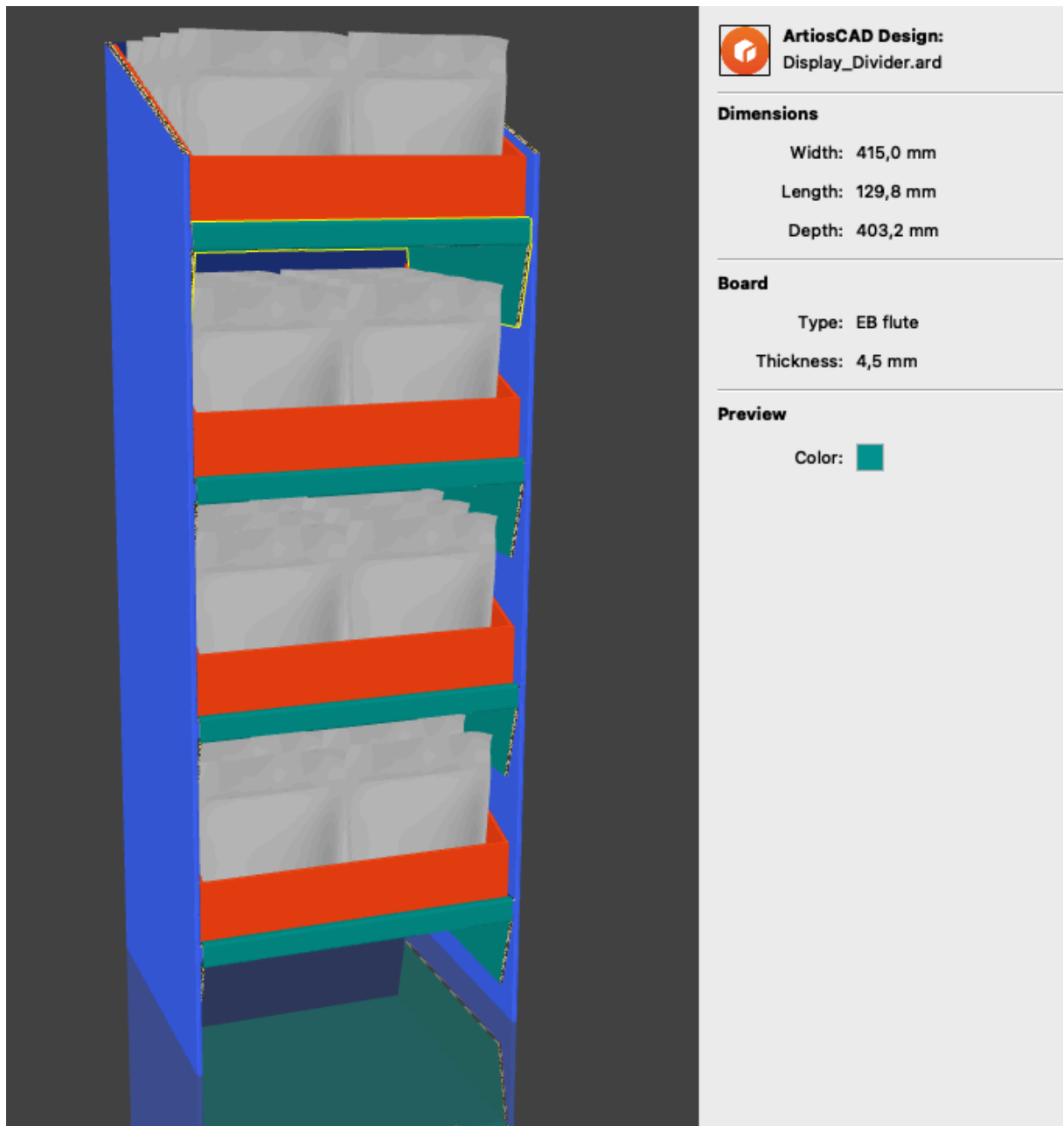

## Changing the View

You can change the view in different ways

1. Click the **Zoom In** button, use its shortcut **Cmd++** (Mac) or **Ctrl++** (Windows) or choose **View > Zoom In** to increase the zoom
2. Can click the **Zoom Out** button, use its shortcut **Cmd-** (Mac) or **Ctrl-** (Windows) or choose **View > Zoom Out** to decrease the zoom
3. Can click the **Fit in Window** button, use its shortcut **Cmd-0** (Mac) or **Ctrl-0** (Windows) or choose **View > Fit in Window** to change the zoom factor so that all objects fit in the window
4. Use the dropdown or the corresponding shortcuts to change the **View mode**

View Mode	Shortcut	Changing the camera view point & Transforming objects
Perspective	<b>1</b>	The default view mode, in which you can change the camera view point and transform objects along all 3 axis.
Front	<b>2</b>	In any of these view modes, you can only see all objects in one pane. You can also only change the camera view point or transform objects within the visible plane.  For example, it is not possible to move objects up or down when in <b>Top</b> or <b>Bottom</b> view mode
Left	<b>3</b>	
Back	<b>4</b>	
Right	<b>5</b>	
Top	<b>6</b>	
Bottom	<b>7</b>	

5. You can move and rotate the camera view point when in **Perspective** view mode
  - a) Click and drag to rotate the camera
  - b) Hold the **Shift** key and click and drag to move the camera viewpoint
  - c) If another tool is active, you can hold the **Space** key, and click and drag to rotate the camera
  - d) If another tool is active, you can hold the **Space** and **Shift** key and click and drag to move the camera viewpoint
6. You can move the camera view point when in another View mode
  - a) Click and drag to move the camera viewpoint
  - b) If another tool is active, click and drag to move the camera viewpoint
7. Select **View > Go to 2D/3D** or use the shortcut **Cmd-G** (Mac) or **Ctrl-G** (Windows) to switch between the 3D and 2D tab. If there are multiple 2D tabs, the 2D tab of the currently selected object is used if possible. Otherwise, the last selected 2D tab is shown.

### Transform the selected 3D shape(s)

When you are working in **Perspective View** (see [Changing the View](#) on page 58), you can move and rotate any object based on 3 axis.

In other View modes, the transformation tools work in 2 direction depending on the chosen view plane. For example, in **Front** view, you can move and rotate only in the front plane (X and Y axis)

Underneath, the different transformation tools are explained for the **Perspective** view.

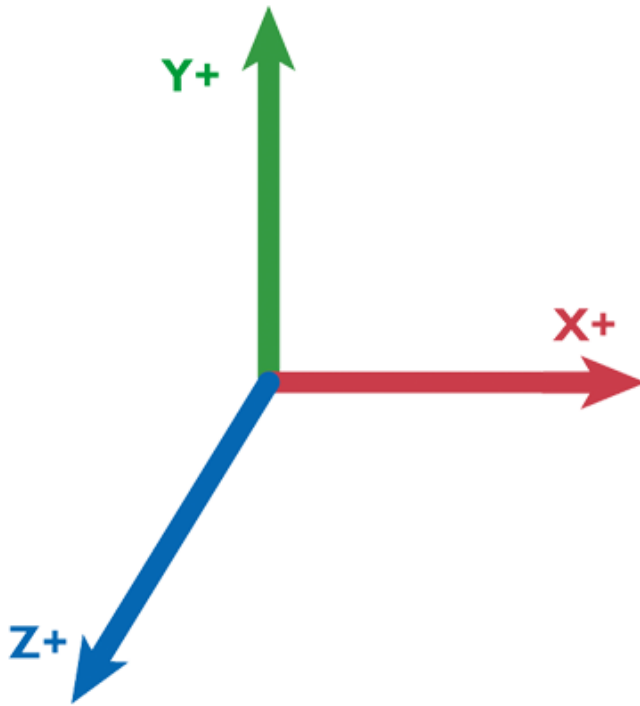

If the **Transform** tool is selected, you can select one of four modes in the settings bar:

- Select  **Simple Transform** or use its shortcut **T**

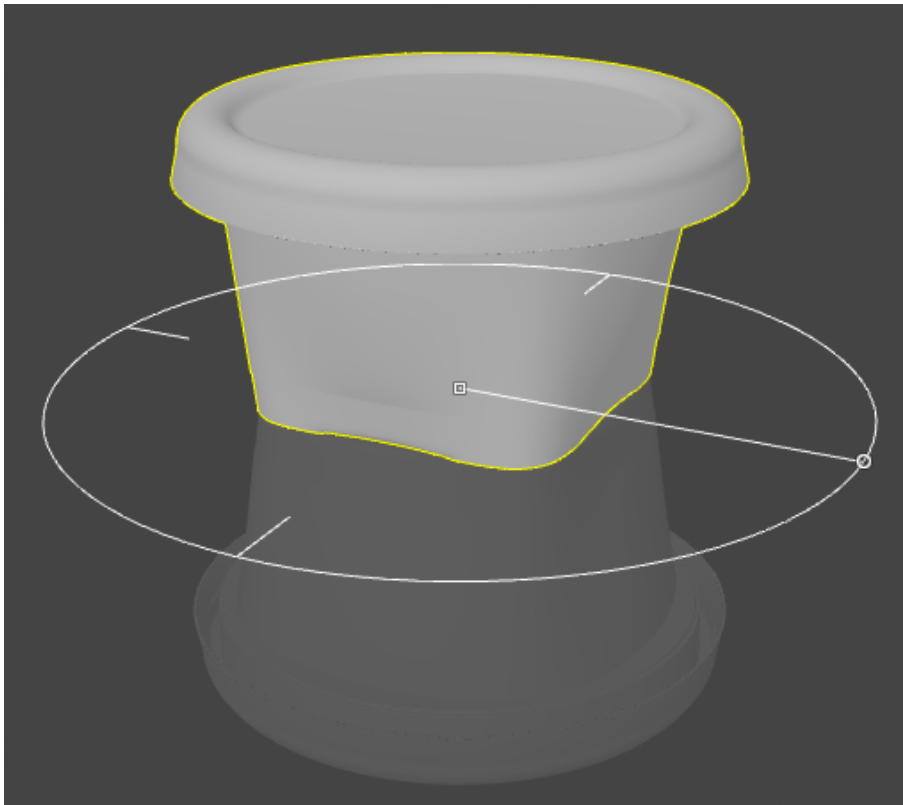



- Click and drag the center anchorpoint or change the **Offset X** and **Z** value to move the object over the X and Z axis. Holding down the shift while dragging will constrain the movement to either only along the X or Z axis.
- Click and drag the anchor point on the circle or change the **Rotation** value to rotate the object on the Y axis. Holding down the shift while dragging will constrain rotation to multiples of 45 degrees.
- Simple Move and Rotate keeps the object aligned with the floor. However, by setting the **Distance from Floor** option in the settings bar, you can also move the object over the Y axis,.
- If you enable **Snap**, the selected objects will snap to align to other objects. The object(s) your selection is snapping to will be temporarily be highlighted. Holding down the shift while dragging will constrain the snapping to either only along the X or Z axis.

Select  **Move** or use its shortcut **M**

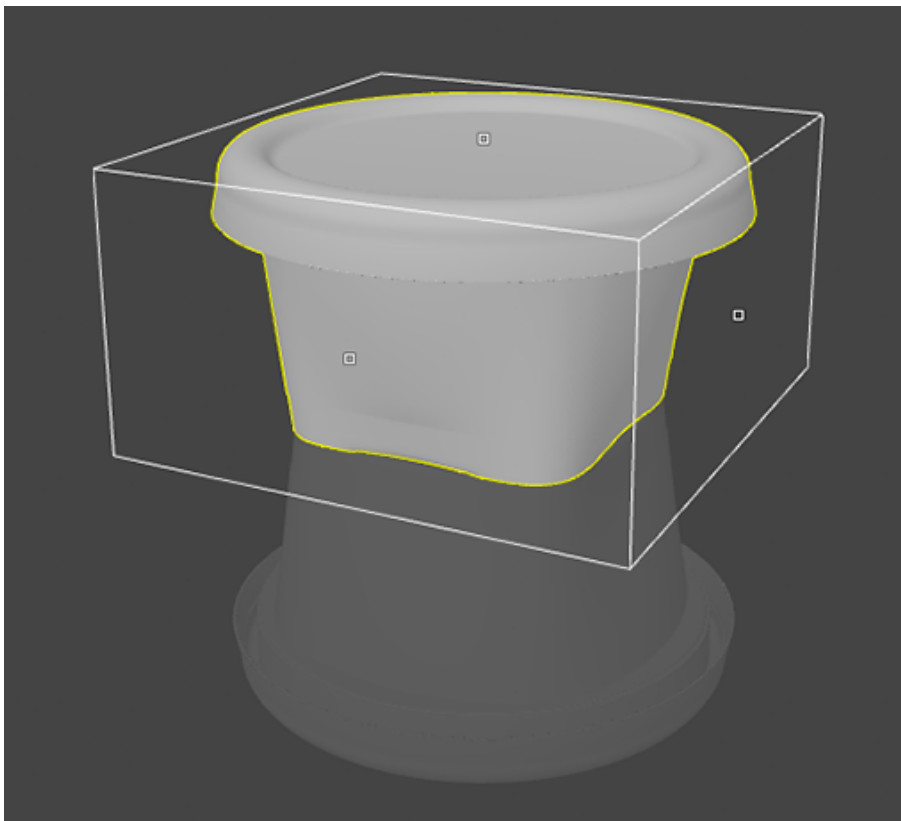

- Click and drag any of the anchorpoints or change the **Offset X, Y** or **Z** value to move the object over the X, Y and Z axis.
- If you enable **Snap**, the selected objects will snap to align to other objects. The object(s) your selection is snapping to will be temporarily be highlighted.
- When moving an object down towards the floor while snapping is enabled, the object will snap to the floor, and the bottom of the object will highlight when the distance to the floor becomes 0.

- Select  **Rotate** or use its shortcut **R**



- Click and drag any of the anchorpoints or change the **Rotate X, Y** or **Z** value to rotate the object over the X, Y and Z axis. Holding down the shift while dragging will constrain rotation to multiples of 45 degrees.



**Note:** When moving or rotating a 3D shape, the depending parts (sleeves and labels) are moved / rotated along.

- Select  **Scale** or use its shortcut **S**

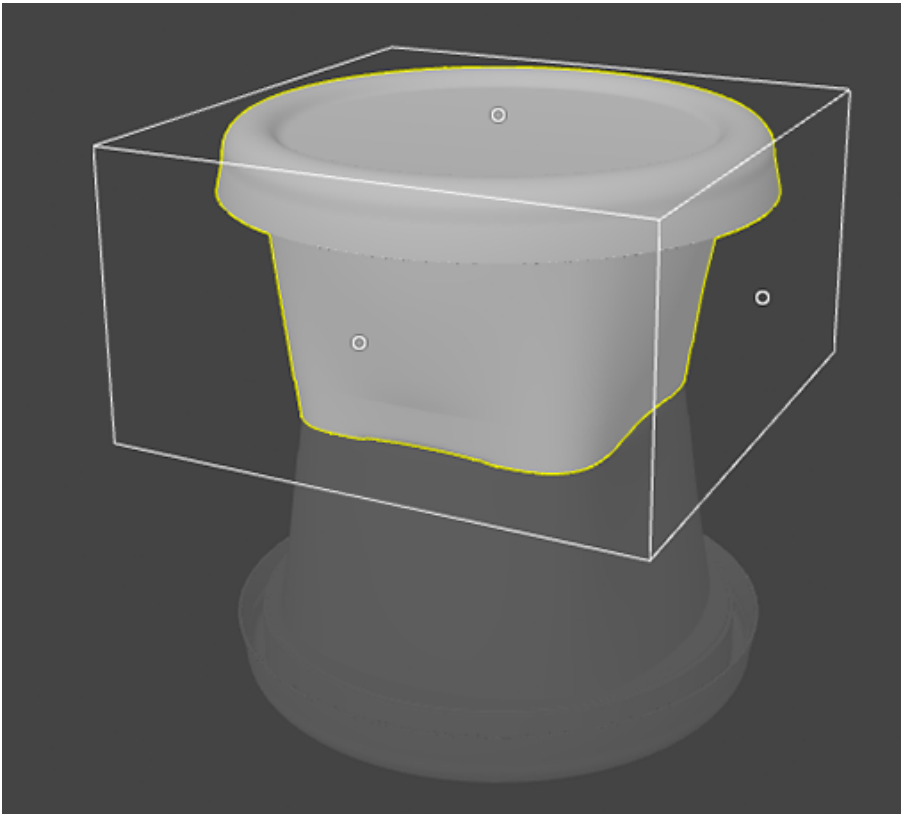

- Click and drag one of the anchor points to change the size of the object, using the opposite anchor point as center of origin. If you hold down the **Alt** key, or if you adjust the values in the Scale width, height or depth field, the scaling is done from the 3D mid point of the object.
- By default, the **Uniform** option is selected, so the object is scaled uniformly in the 3 directions. Changing the value for Scale width, height or depth will change the two other values as well.
- By deselecting **Uniform**, you can scale the object in any direction. You can restrain the scaling to uniform by holding down the **Shift** key.



**Note:** Holding down the Shift key does not give the same result as selecting the **Uniform** option again: the first will only restrain the current transformation to Uniform, while reselecting **Uniform** will adjust the complete transformation of the object to a Uniform scaling.

The **Scale** tool is only available when an imported Collada file or OBJ file is selected. It is not available for Bag files, ARD files or for objects that already have a Sleeve or a Label attached in Studio Toolkit for Shrink Sleeves or Studio Toolkit for Labels.

The scale option performs a scale of the three dimensional shape of the selected object. The uniform scale is very useful to correct an object that has suffered from an incorrect unit-conversion from a 3rd party CAD system. The non-uniform scale can be powerful to fine-tune the dimensions of an imported product so that it fits into its packaging.

The scale option is not suitable for printable parts as their size affects other aspects such as the 2D drawing and the artwork mapping. A straightforward scale of a printable object in 3D would result in unwanted side-effects.

To change the size of printable objects, you should use other tools instead:

- To scale an object with a label or a shrink sleeve, first scale the container (without the label or sleeve) and then add the label or sleeve.
- To scale a flexible bag, modify its dimensions in the details panel.
- To scale a box, tray or carton, or a shape created in a third party application, go back to the application where you created it (Toolkit for Boxes, ArtiosCAD, the third party application used to create the shape).
- For Shapes models, you can order a new (scaled) variant via Esko's 3D modeling service.

If you click and drag but not on any of the anchor points, you will change the camera position, but the object will NOT move or scale. This might be necessary to make all handles visible.

**Tip:**

After rotating or scaling, you might need to align the object with the floor again. You can do so by switching to Simple Move and Rotate, and set the **Distance from floor** to zero.

For vertical alignment, you can also use **Drop Down** and **Lift Up**. See [Drop Down and Lift Up](#) on page 64

## Nudge

When creating compositions it is sometimes much easier and faster to simply move an object into its final place by using the arrow keys. This is called nudging. Nudge works on any selected object, even without the Transform tool activated.

It is available in all 3D views.

- The arrow keys move the selected 3D objects over the distance defined in the Preferences. Holding down the Shift key multiplies the step by 10.
- In **Perspective** view, the arrow keys let you move in the horizontal floor plane. Use the option + up (Macintosh) or alt + up (Windows) or down keys to move the object up or down.
- In the axis-aligned views (Front, Left, Back,...) the arrow keys let you move in the corresponding direction on screen. In those views upwards or downwards movement is not available.

## Drop Down and Lift Up

You can use **Drop Down** and **Lift Up** to put an object on top of another object or put it on the floor.

The selected objects are moved (down or up) to the next intersection free position where the selected objects is on top of another object or on the floor.

Objects that are (partially) underneath the floor can only be moved upwards.

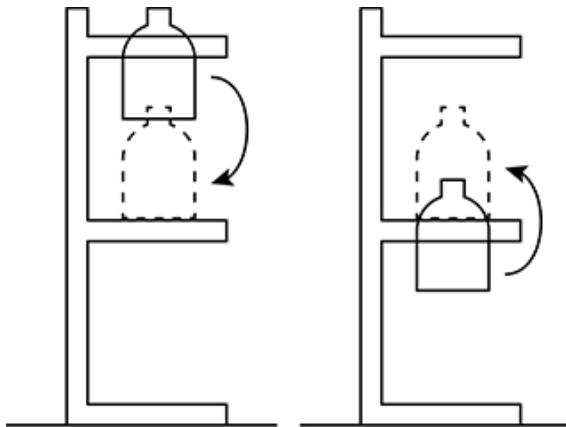

- To drop down: select **Edit > Drop Down** or use its shortcut **Cmd + Arrow Down** (Mac) or **Ctrl + Arrow Down** (Windows)
- To lift up: select **Edit > Lift Up** or use its shortcut **Cmd + Arrow Up** (Mac) or **Ctrl + Arrow Up** (Windows)

### Repeat

Using the **Repeat** button, you can create a simple repeat of the selected object(s).

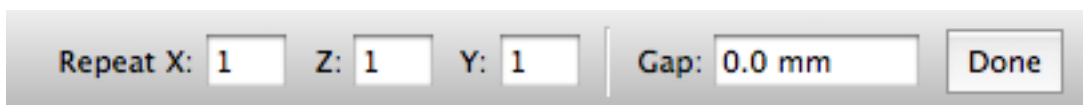

- Enter the number of repeats you want along the X, Z and Y axis
- Enter a **Gap** value to add distance in between the objects
- Click **Done**

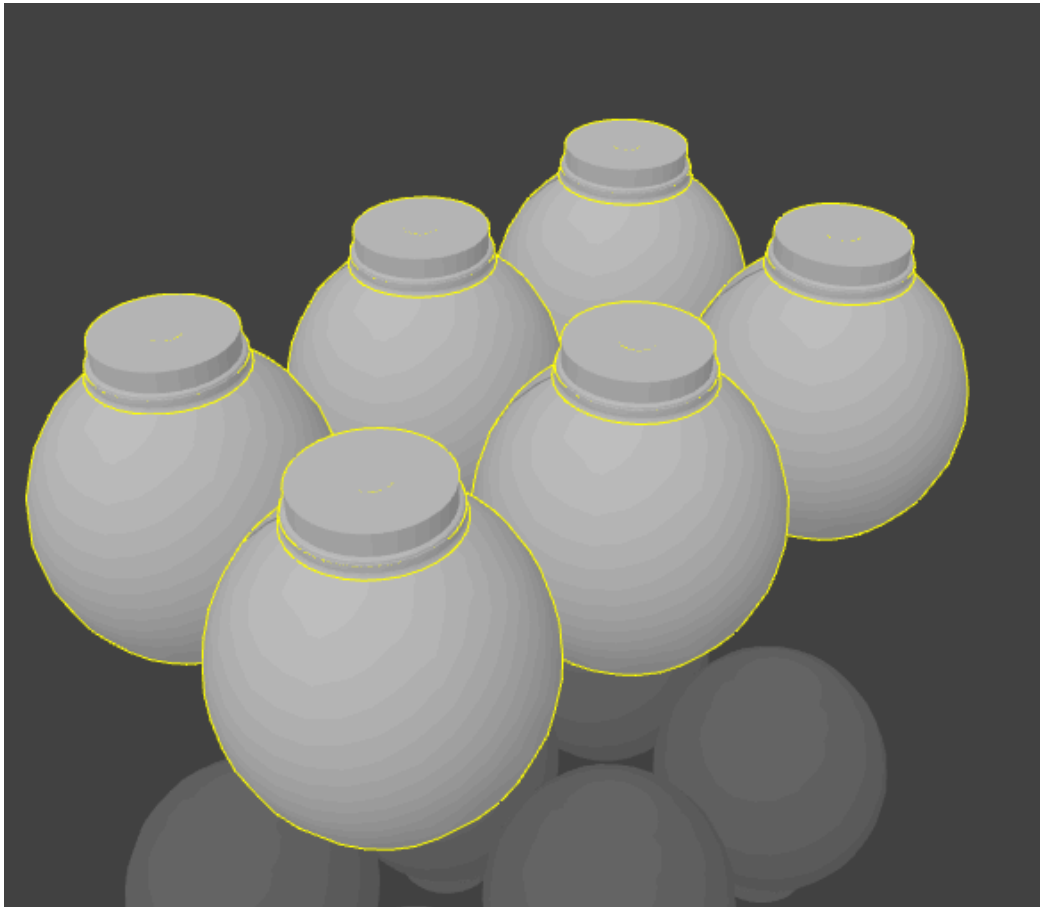

After the repeat, you will have multiple instances of a single object. This means making changes to one of the objects will also modify the others, while you can move and rotate the instances independently.

If you have one instance selected, you can use **Edit > Select all copies** to select all instances.



**Note:** All instances of the object will use the same Printable Part. This means that all instances will share the same graphics. See [Different graphics on shapes of the same size](#) on page 160

## Selecting objects

When you import or create objects in Studio Toolkit you also might need to select them. Go to the **Edit** menu to view the selection options.

There are several ways of selecting objects:

- Simply click on an object to select it.
- Hold Shift and click to select multiple objects.
- Use the Cmd-A (Mac) or Control-A (Windows) shortcut to select all the objects.
- When an object that is part of a repeat is selected, you can use **Select all copies** to select the other instances of the repeat. You can also use the Cmd+Option+A (Mac) or Control+Alt+A (Windows) shortcut.



**Tip:** By holding the option (Mac) or alt (Windows) key and clicking on one object several times, you can select objects that are behind the selected object.



**Note:** Most selection options also work in 2D view.

## Replace Imported Shape

When you select an imported shape (ArtiosCad ARD file or a Collada file), you can use the **Replace** button in the info pane on the right side to import another shape, replacing the selected one.

The newly imported shape will keep the position and preview color of the originally selected shape.

If you are replacing shapes in a structural design document that is already used in Adobe Illustrator:

- If a printable part of the structural design file is used in Adobe Illustrator, the name of the printable part should stay the same to guarantee the printable part is correctly replaced when updating the structural design file in Studio in Adobe Illustrator. You can change the name of a printable part by editing the 2D tab name in Studio Toolkit.
- If the structural design file is loaded as a scene in Studio, and you no longer see the correct artwork on the replaced printable part, you should place this new printable part in the Illustrator document with the artwork.

## Tabs

At the bottom of your Studio Toolkit window, you can see the different **Tabs**.

First is always the **3D** tab. Next to that, a 2D tab is shown for every 2D object created in Studio Toolkit: a Sleeve, a Label, a Bag, ...

Deleting an object will also delete the corresponding 2D tab. Different instances of the same object (created using **Repeat**) share the same 2D tab. In that case the 2D tab will be deleted if the last instance of the object is removed.

You can rename any 2D tab by double clicking the name and entering the new name.



**Note:** The name entered for the 2D tab will be stored as the name for the technical drawing in the collada file, and will thus be used when importing the collada file e.g. in Studio Designer.

You can switch between the 3D tab and the 2D tab of the selected object, by choosing **View > Go to 3D** or **View > Go to 2D**, or by using its shortcut Cmd-G

## Measurements

Using the **Measurements** tool in the 2D drawing of a bag, shrink sleeve or label, you can add essential **measurements** to the technical drawing.

The measurements you set up are automatically recalculated if you change the dimensions or other settings of a bag. In some cases, if the changes are too drastical, some measurements might be removed.

All measurements are saved inside the Studio Toolkit file and visible when placed in e.g. Adobe Illustrator. When placed in Adobe Illustrator, the measurements are placed in a separate sub-layer of the Structural Design file.

## Adding measurements

To add new measurements:

1. Select the 2D tab in which you want to add measurements
- 2.



Select the **New Measurement** tool

A measurement is drawn between the points of line intersections. When the **Measurement** tool is activated those points are clearly visible and light up when nearly selected.

3. Click and drag from one intersection point to another to add the measurement to your document.

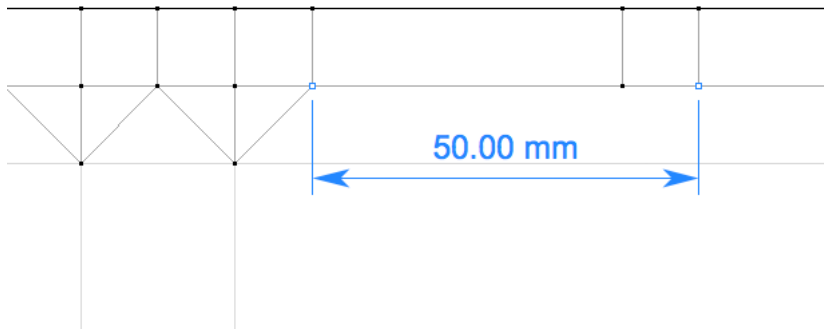

**Note:** When measuring slanted lines, you will see either the vertical or horizontal distance. See [Slant measurements](#) on page 69

### Setting up measurements

You can change the way measurements are shown on your document

1. Select the 2D tab in which you want to change the measurements
2. Select the measurement(s) you want to modify.



**Note:** You don't need to have the **New Measurements** tool active to select and modify a measurement.

The palette will show the settings of the selected measurement.



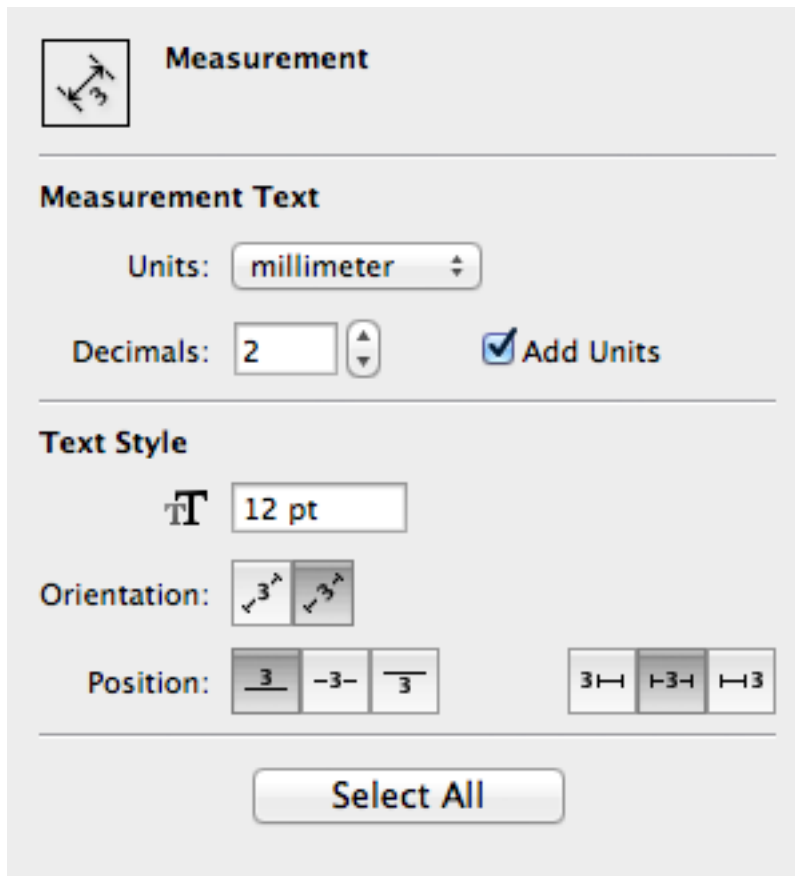

**3.** Make the changes you want

- click and drag the measurements to move them closer to or further away from the intersection points.
- for slant measurements, click and drag to rotate the measurement. See [Slant measurements](#) on page 69
- In the Measurement Text section, change the unit for the selected measurement, the number of decimals, and whether or not the units need to be shown.
- In the Text Style section you can set the text size in points. Note that the size of the arrow heads is changed accordingly.
- You can define if the text should always be horizontal, or according to the measure line. In the latter case, you can define if the text should be above, on or below the line. You can also set if the text should be positioned on the left / bottom, on the center or on the right / above.
- Click the **Select All** button to select all measurements at once. This allows to change the units, font size, ... for all measurements in one go.

**Slant measurements**

When measuring slant lines, or simply measuring between two points that are not on a vertical or horizontal line, the measurement will by default show either the vertical distance or the horizontal distance, whatever is the biggest value.

If you want to change what distance to show (either vertical, horizontal or slanted distance), you can do so by clicking and dragging the measurement to rotate it.

Below you see some different results for the same two intersection points.

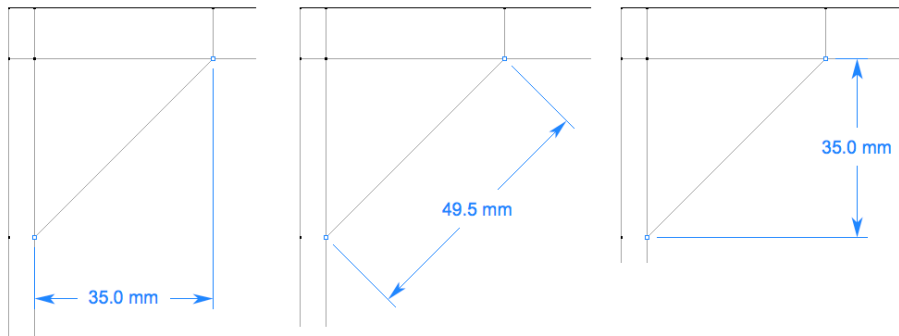

### Preferences

You can open the preferences by choosing **Studio Toolkit > Preferences...** (Mac) or **Edit > Preferences...** (Windows).

In the preferences, you can set the **Keyboard Increment** for nudging (see [Nudge](#) on page 64), the unit to be used for **Dimensions** (millimeter, centimeter or inch) and for **Volumes** (milliliter, centiliter or US fluid Ounce).

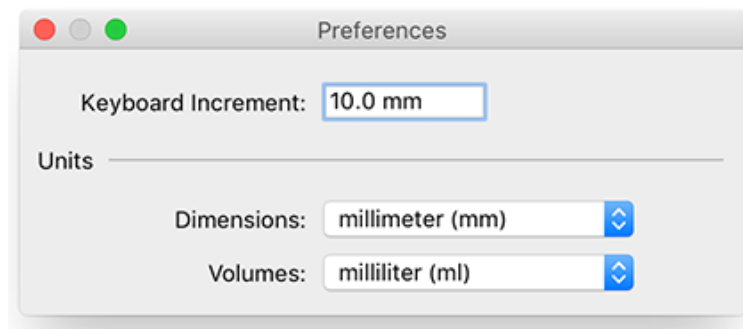

## 3.2. Create a 3D Sheet

A **3D Sheet** is a 3D representation of a simple sheet, that can be used e.g. to visualize finishing operations in Visualizer quality.

You can only create a 3D Sheet if no Structural Design file is placed in the current document.

1. To view the Studio window, choose **Window > Esko > Studio Designer > Show Studio** or use the shortcut **Cmd+Alt+4** (Mac) or **Ctrl+Alt+4** (Windows).
2. Click **Create a 3D sheet** in the Studio window, or select **3D Sheet...** in the fly-out menu of the Studio Window.

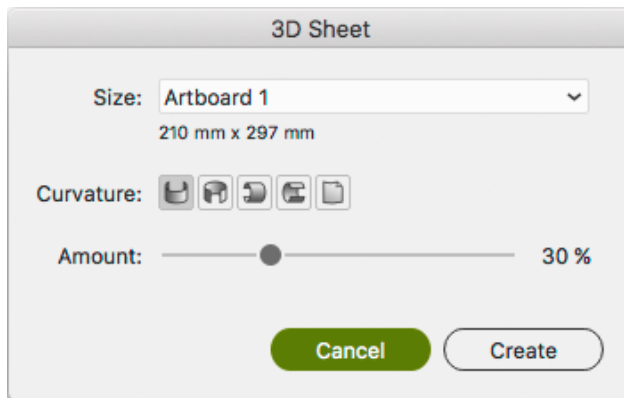

3. Select the **Size**. You can select any Artboard, or any DeskPack Page Box defined in the document.  
You can set DeskPack Page Boxes using the Trim Box and Media Box plugin, part of Esko Data Exchange and installed along with Studio: **Window > Esko > Trim Box and Media Box**
4. Set the shape of the sheet by selecting the **Curvature** and setting the **Amount**.
5. Click **Create**

You can change the settings of your 3D sheet by selecting **3D Sheet...** in the flyout menu of the Studio Window, changing the settings and clicking **Modify**

You can remove a 3D sheet by selecting **Remove** in the **Scene** dropdown. Placing a Structural Design file will also remove the 3D sheet.

### 3.3. Create a box

---

You can create a box or any other folded structure, such as a tray, in Adobe Illustrator using the Studio Essentials tools.

- You can create a basic box from scratch. See [Creating a Basic Box](#) on page 71
- You can create a box based on die lines, e.g. from an imported die shape. See [Create a box based on die lines](#) on page 75

Sometimes a die-drawing fails to fold properly because of inaccuracies in the die drawing. In that case, you can use the Studio Essentials tools to check, correct and fold a placed ARD file.

See

- [Check the die and solve inaccuracies](#) on page 80
- [Fold ArtiosCAD file](#) on page 85

#### 3.3.1. Creating a Basic Box

This tool lets you create a simple rectangular box. This can be used to start working on a design before you get the final die lines, or to create a simple box from within Illustrator.

1. Open the **Create Basic Box** dialog:
  - Choose **Window > Esko > Studio Toolkit for Boxes > Create Basic Box**

- If you have no Structural Design in your document, you can access this tool from the (empty) **Studio** window, by clicking **Create Basic Box**.

The **Create Basic Box** dialog appears.

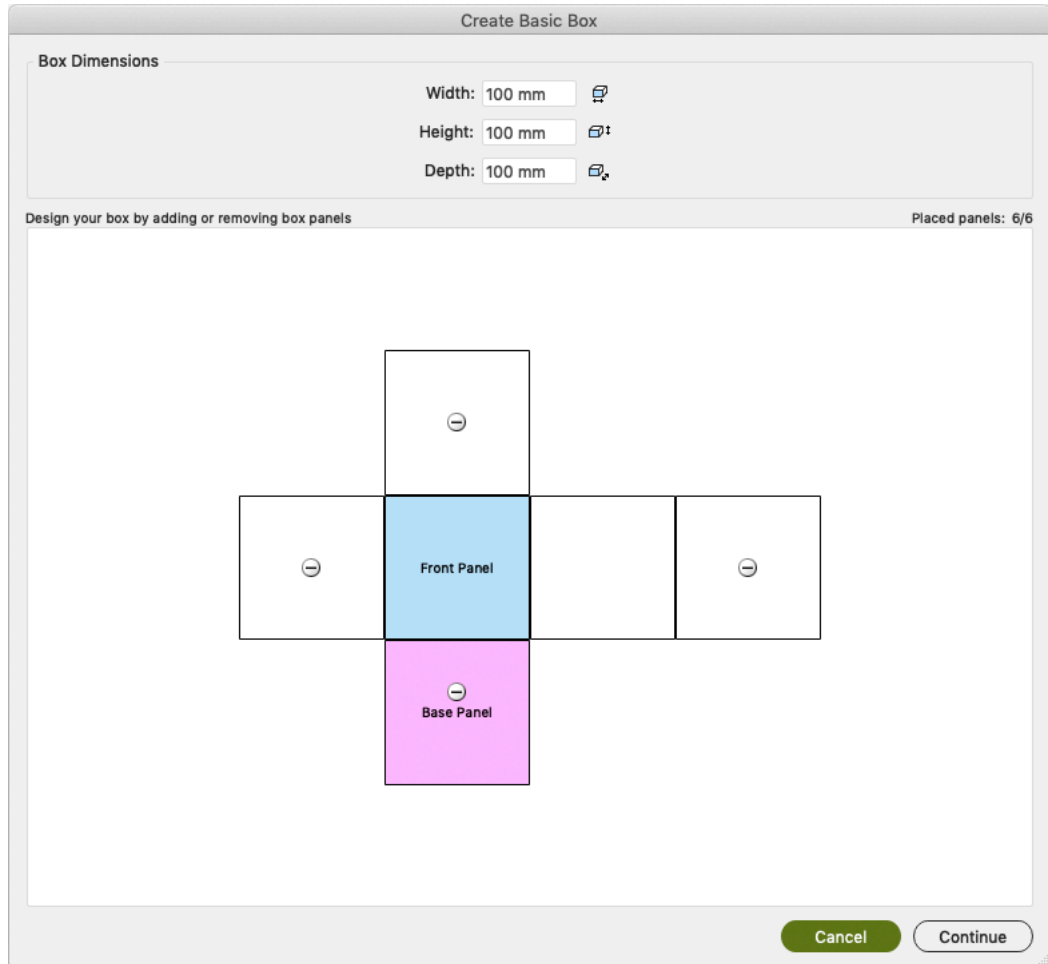

2. Fill in the **Width** , **Height** and **Depth** for the box you want to create.
3. Define the Panels. You can choose how your box is built by adding or removing panels. The box must have 6 panels to continue.
  - Remove a panel clicking the - button
  - Add a panel clicking the + button
4. Click **Continue** .

You now get a 3D preview of the closed box.

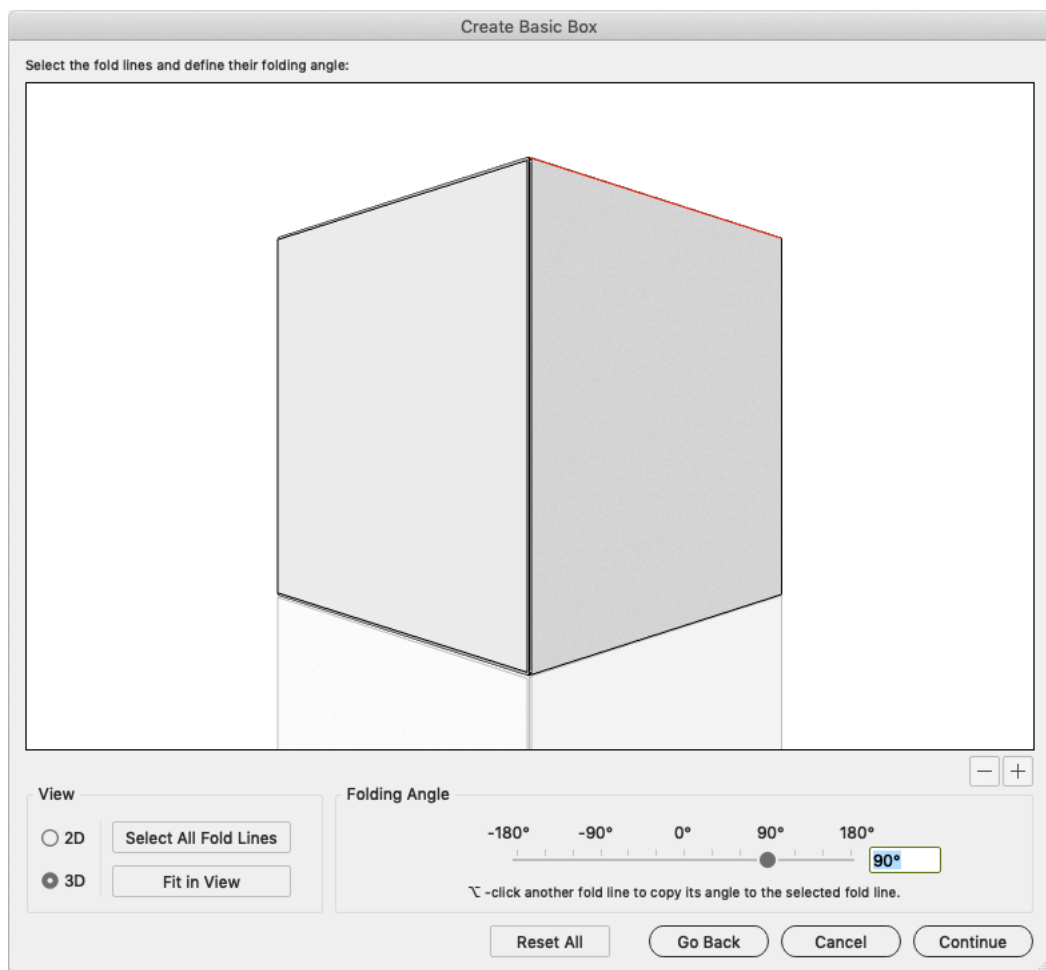

5. If you want to modify the fold angles of one or more faces, select a fold line and use the slider to change the fold angle. You can also enter a value manually, or click one of the labels above the slider.

6. Click **Continue** .

The box turns to its **Front View**.

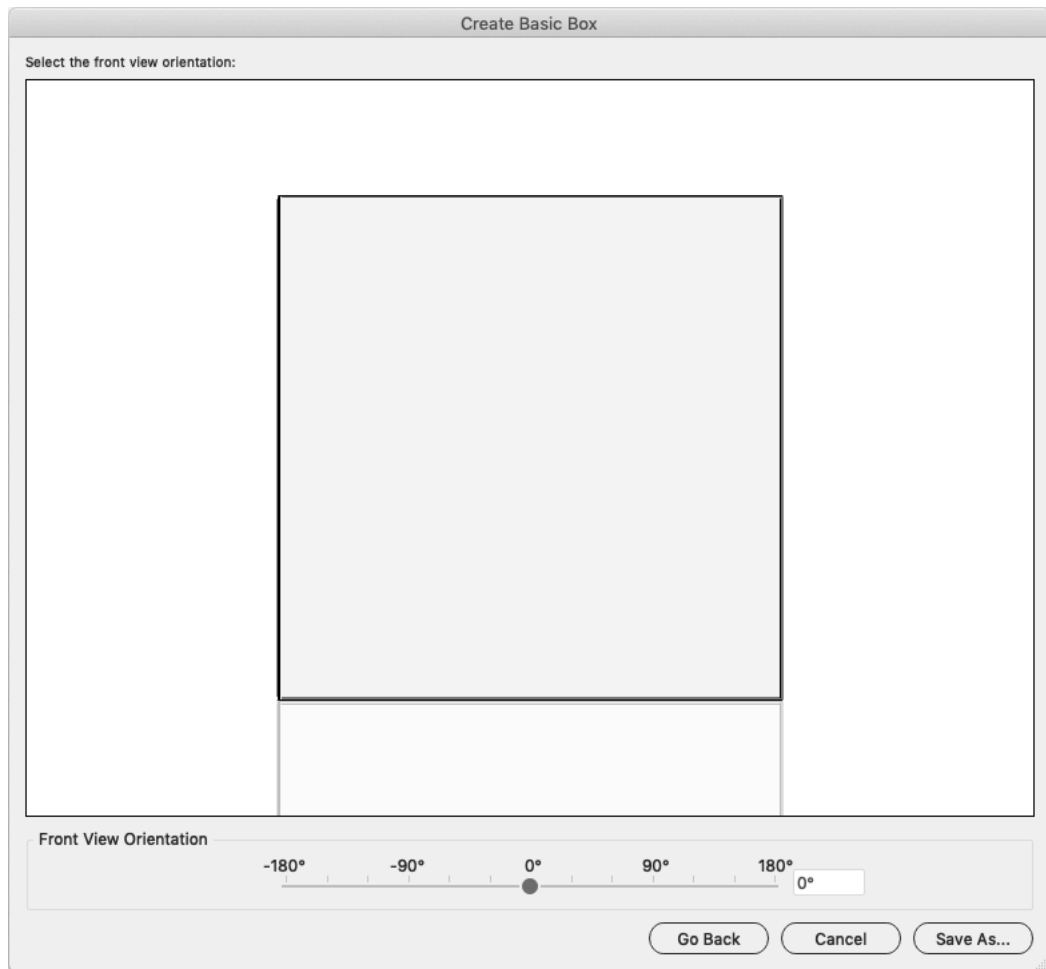

7. If you want to modify the **Front View Orientation**, you can click and drag the box interactively in the 3D view, or use the slider to change the angle. You can also enter a value manually, or click one of the labels above the slider.

The Front View Orientation is used when applying the **View Preset** "Front" in the Studio window. See [View](#) on page 149

8. Click **Save As** to save the result as an ArtiosCAD ARD file.
9. Define the name and location for the file.
10. You get the option to place the file directly in the document.  
If you click **Yes** :
  - the **Studio** window will show the folded ArtiosCAD ARD file. The new ARD file will be placed next to already placed Structural Design files.
  - the selected items will be moved to a locked layer.
11. You can also use the ArtiosCAD ARD file in Studio Toolkit.



**Note:** Keep in mind that the resulting box is not a technically accurate and produceable box.

### 3.3.2. Create a box based on die lines

You can create a box starting from a die drawing. This can be any die drawing that you imported in Illustrator.

To fold a die drawing to a folded box, you use the **Fold** window: choose **Window > Esko > Studio Toolkit for Boxes > Show Fold Window** .

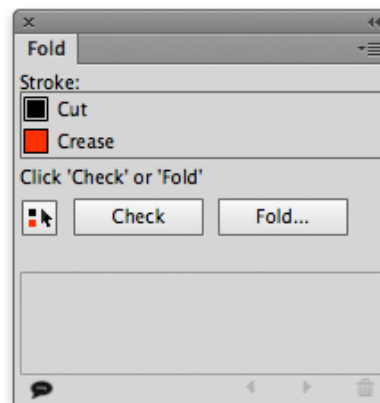

The **Fold** window assists you in all necessary steps to fold a die:

1. Assign fold and cut lines. See [Assign fold and cut lines](#) on page 76
2. Fold the design, using the **Fold** button.
3. Sometimes a die-drawing fails to fold properly because of inaccuracies in the die drawing. In that case, you need to check the die and solve any inaccuracies:
  - by going back one step and using the **Check** function and manual correction;
  - by using **Automatic Correction** in the **Fold Selection** window.
4. Select a base panel. See [Select the Base Panel](#) on page 77
5. Select a board and fill in the board thickness. See [Select the Board and Board Thickness](#) on page 78
6. Set the fold angles. See [Set the folding angles](#) on page 78
7. Set the front view. See [Set the Front View](#) on page 80
8. Click **Save As** to save the result as an ArtiosCAD ARD file.
9. Define the name and location for the file.
10. You get the option to place the file directly in the document. If you click **Yes** :
  - the **Studio** window will show the folded ArtiosCAD ARD file. The new ARD file will be placed next to already placed Structural Design files.
  - the selected items will be moved to a locked layer.
11. You can also use the ArtiosCAD ARD file in Studio Toolkit.

### Assign fold and cut lines

After importing a die drawing into Illustrator, you have to indicate which lines represent a cut and which lines represent a fold line or “crease”.

A line is indicated to be a cut line by applying the designated ink named “Cut”. A line is indicated to be a crease line by applying the designated ink named “Crease”.

- Select the proper paths, and click the **Cut** or **Crease** swatches in the **Fold** window.
- If you want a single path to be partially a cut path and partially a fold line, select the path, and select **Split Paths** from the flyout menu in the **Fold** window. This will split the selected path in different segments, so that the fold lines can be selected apart from the cut lines.
- With some die drawings it is hard to assign cut and crease strokes to the lines because the die drawing consists of rectangles on top of each other. This creates double lines. **Remove Double Lines** in the flyout menu of the **Fold** window will remove the double lines in the selection. This will take all lines in the selection into account, irrespective of the stroke color they have.

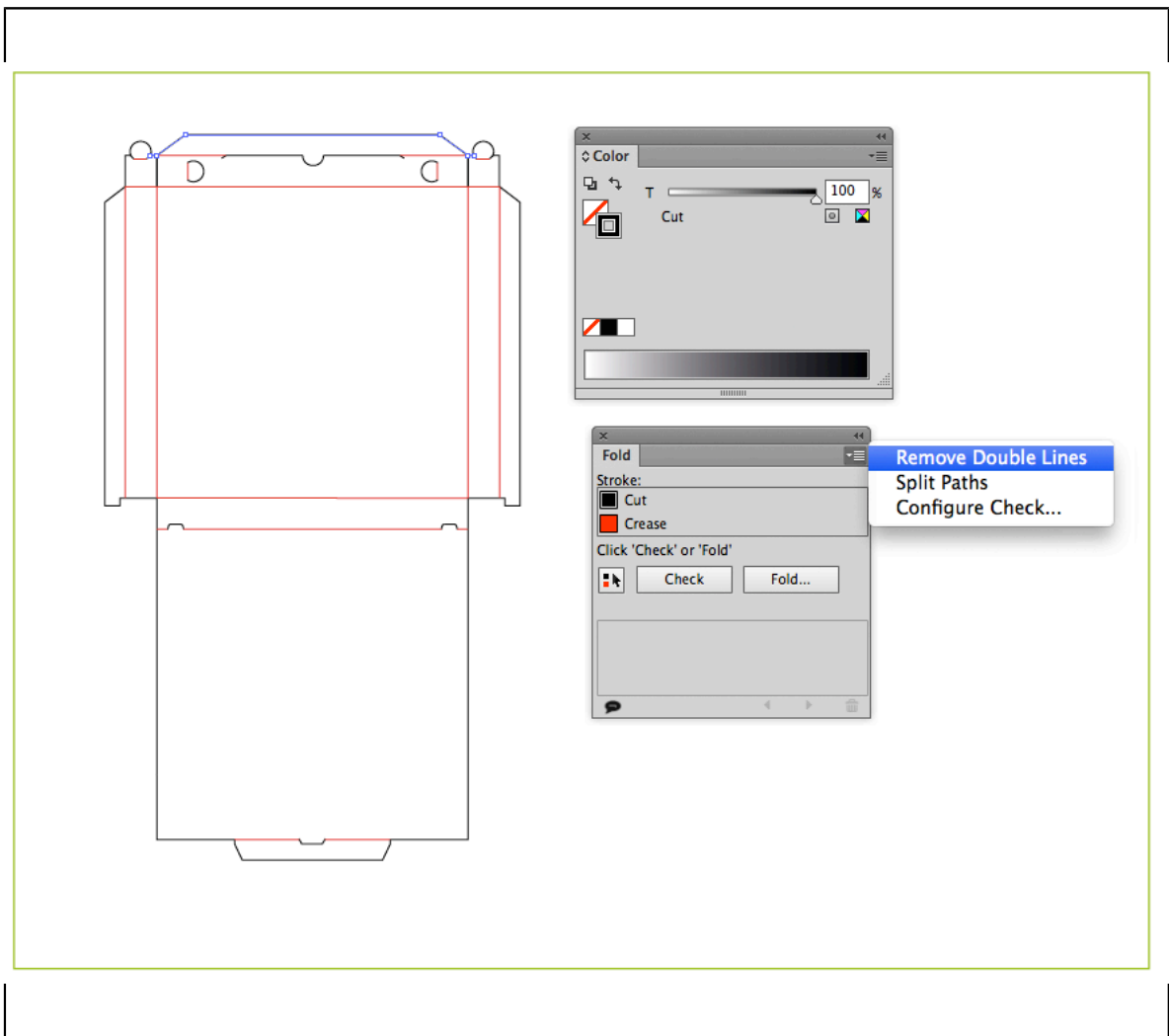



### Select the Base Panel

The Base Panel is the panel that will be facing down. All other panels are folded relative to this base panel.

1. Select all cut and crease lines by clicking the **Select All Cuts and Creases** button in the **Fold** window. 

2. Click the **Fold** button.



**Note:** If you don't see all the panels, or if you are not able to select the base panel you had in mind, there could be inaccuracies in the die. In that case you need to check the die and resolve any inaccuracies.

3. Select a Base Panel.
4. Click **Continue**.

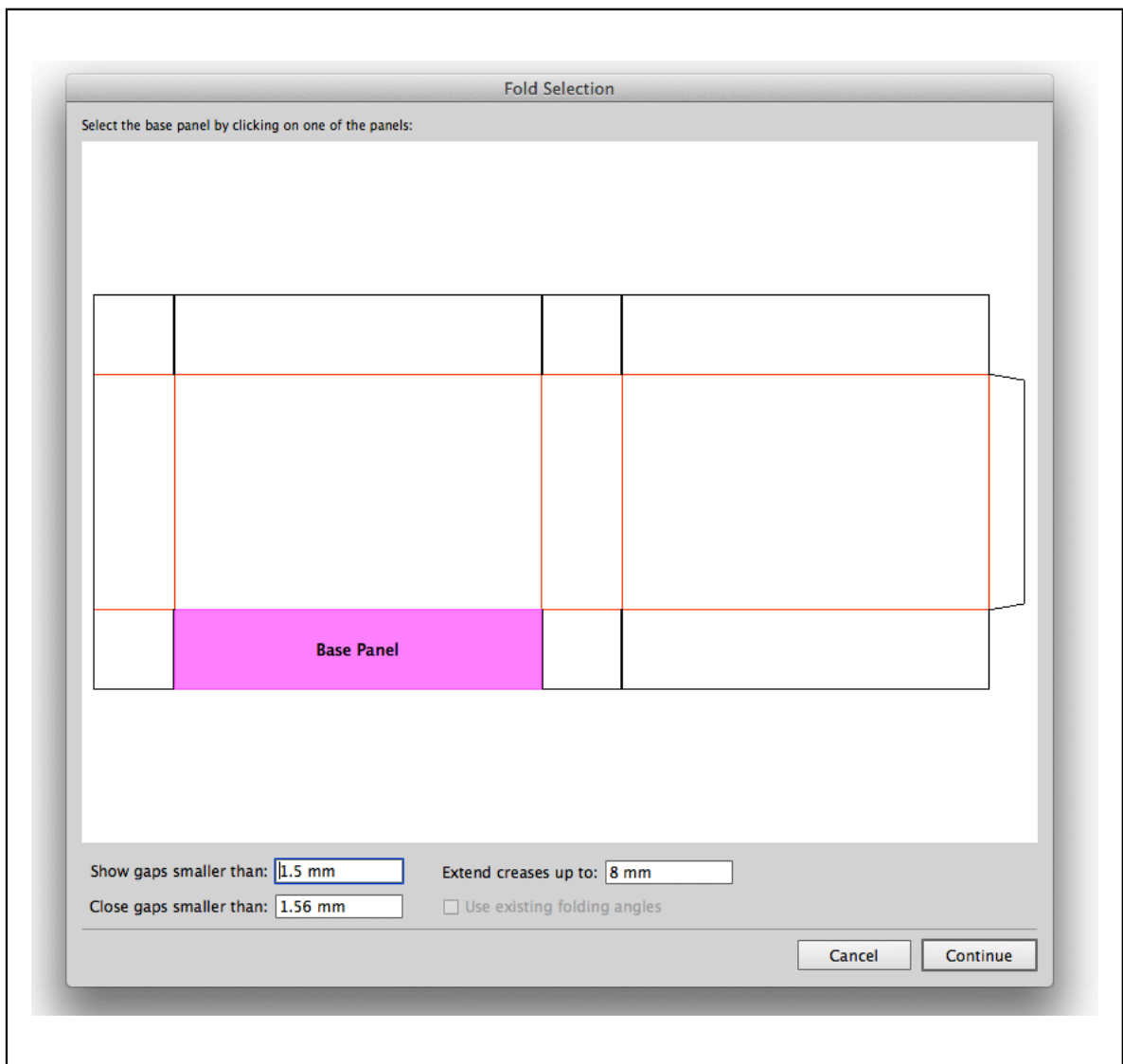

### Select the Board and Board Thickness

1. Select the correct board by choosing one of the boards and fill in the board thickness.
2. Select the **Flute direction**
3. Click **Continue** .

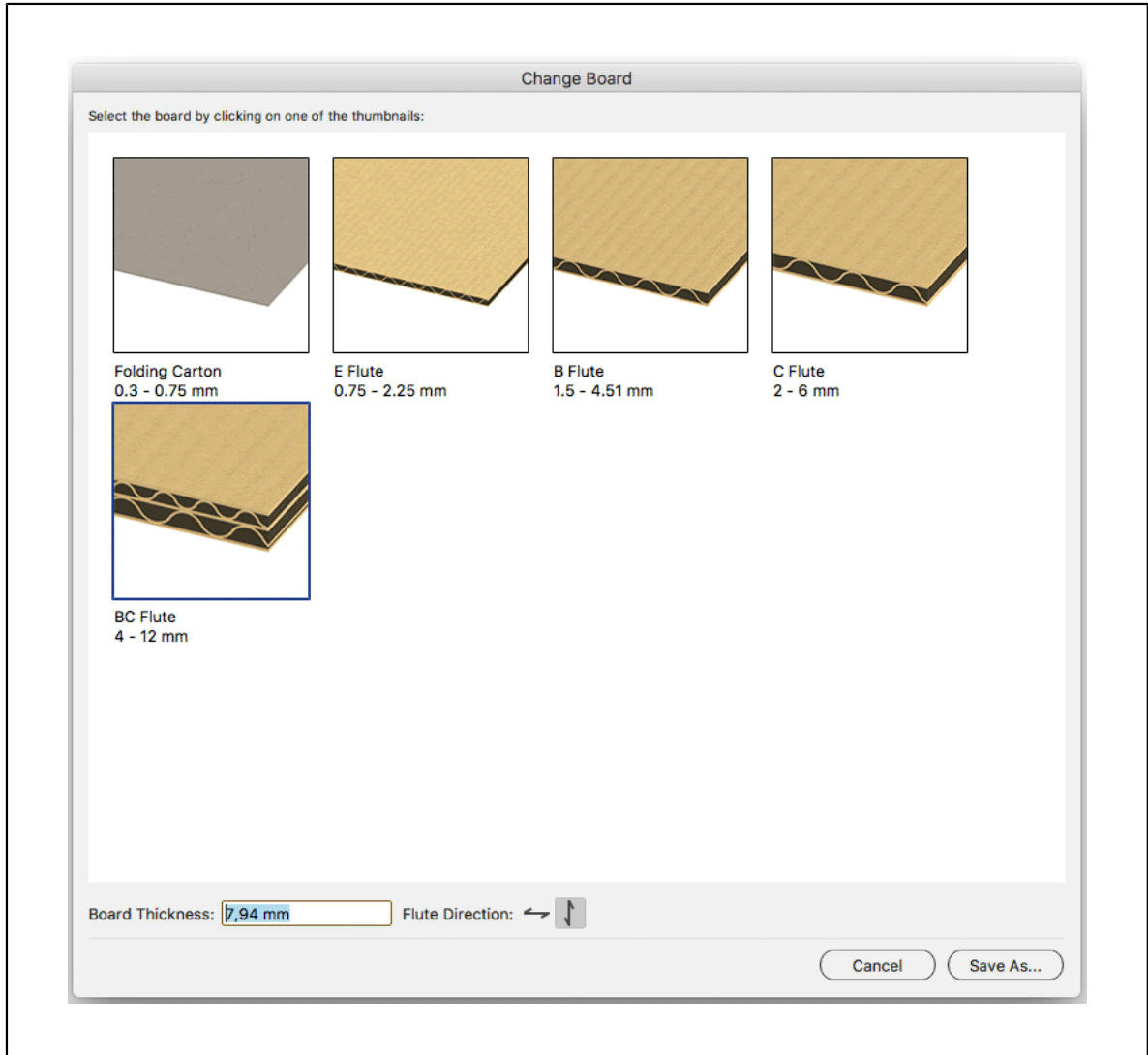

### Set the folding angles

After selecting the cut and crease lines, defining the base panel and choosing a board you will get a preview of the design in 3D, laying flat on the floor with the backside facing up. The box can be folded by defining the fold angles for all fold lines:

- Select a fold line by clicking on it, and specify the fold angle using the slider or by entering the value in the **Folding Angle** field.
- Hold down the **Shift** key to add or remove fold lines to the selection.
- Click **Select All Fold Lines** to select and change all fold lines at once.
- You can copy the Folding Angle from one fold line to another:

- a) Select the fold line you want to change
- b) Hold down the **Option** key on Mac or the **Alt** key on Windows, and click on the fold line with the folding angle you want to copy
- You can change the angle of the selected fold line(s) using the arrow keys on your keyboard:
  - a) up / down changes the value in steps of one degree.
  - b) Shift + up / down changes the value in steps of ten degrees.
- Click **Reset All** to return all folding angles back to the angles you started with.

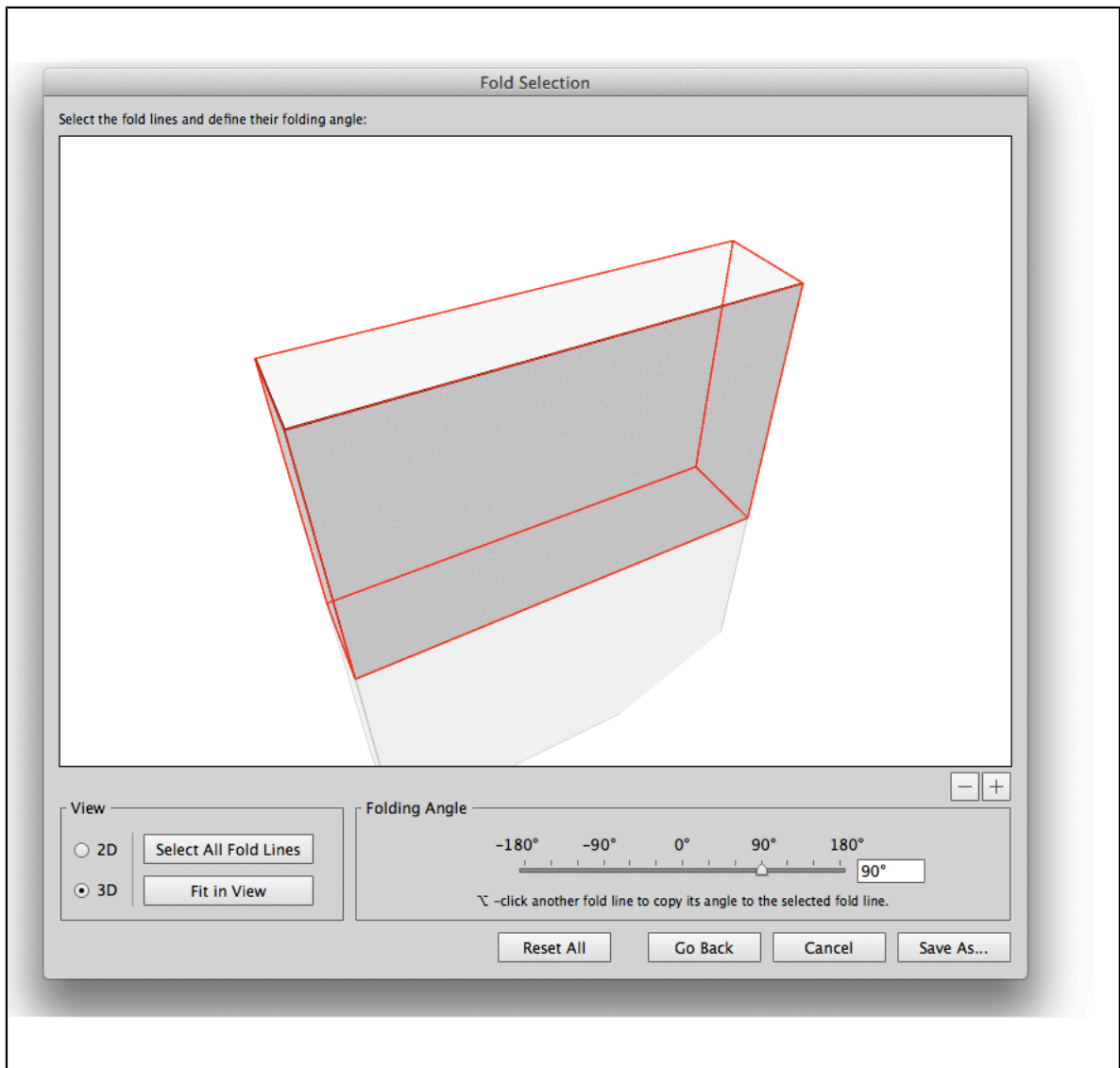

### Switching between 3D and 2D view

In some cases it can be difficult to select fold lines while being in 3D view. In that case, you can switch to 2D view to select the appropriate fold line. After selecting it, you need to switch back to 3D view to change the fold angle.

1. Select **2D** to switch to 2D view.
2. Select the fold line you need. If necessary, you can navigate in the 2D view:

Action	Mac	Windows
Zoom in	Hold down the <b>spacebar</b> and the <b>command</b> key	Hold down the <b>CTRL</b> key and click
Zoom out	Hold down the <b>spacebar</b> , the <b>command</b> and the <b>Option</b> key, and click	Hold down the <b>CTRL</b> and the <b>ALT</b> key and click
Pan	Hold down the <b>spacebar</b> and click and drag	Hold down the <b>CTRL</b> and the <b>SHIFT</b> key and click and drag

View the entire box Click **Fit in Window**

3. Select **3D** to switch back to 3D view.
4. Set the fold angle for the selected folding line.

### Set the Front View

After folding the box, the wizard will turn to the **Front View** of the box.

If you want to modify the **Front View Orientation**, you can click and drag the box interactively in the 3D view, or use the slider to change the angle. You can also enter a value manually, or click one of the labels above the slider.

The Front View Orientation is used when applying the **View Preset** "Front" in the Studio window. See [View](#) on page 149

### 3.3.3. Check the die and solve inaccuracies

When you import a die drawing in Illustrator and define its cut and crease lines, some inaccuracies in the die lines may prevent you from generating a correct and clean fold.

For this reason, Studio Essentials offers a number of tools to check and correct the most common inaccuracies.

#### Checking the die

If the die drawing contains inaccuracies, these can become obvious when creating the fold:



- Panels may be missing;
- An error may appear, stating that some cut lines do not make an outline;
- Inaccuracies may be found and indicated in the **Fold Selection** window;
- ...

A more efficient way to check for inaccuracies and their location is to run a Check.

1. Select all cut and crease lines by clicking the **Select All Cuts and Creases** button in the **Fold** window. 
2. Click the **Check** button. The die lines will be checked for double lines and for gaps.

For every inaccuracy that was found, a marker is placed on top of your document.

If double lines were found, you get the option to clean them up automatically.

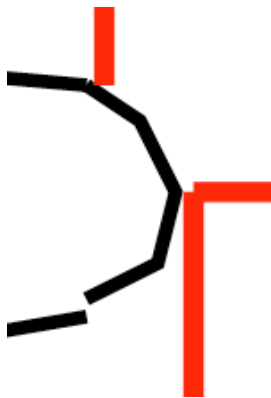
Marker	Type of inaccuracy	Possible corrections
	<b>Double Line</b> marker. Double lines occur when two lines fall exactly on top of each other e.g. when the die drawing was created with rectangles against each other	<ul style="list-style-type: none"> <li>Delete lines manually</li> <li>Use the <b>Remove Double Lines</b> function</li> <li>Clean up double lines automatically after a <b>Check</b></li> </ul>
	<b>Gaps</b> marker. Gaps occur if two lines don't meet exactly as they should. 	<ul style="list-style-type: none"> <li>Manually, using Illustrator path tools</li> <li>Manually, using the <b>Trim and Extend</b> tool</li> <li>Using the Automatic Correction values in the <b>Fold Selection</b> window</li> </ul>

3. Click the entry in the **Marked Inaccuracies** list to zoom in on the first occurrence.

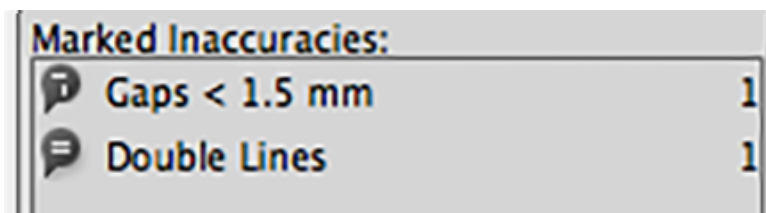

4. Use the **step buttons** in the **Fold** window to step through the markers.



- You can hide and show the markers using the **Show Markers** button in the left bottom corner of the **Fold** window.



- You can remove all markers by clicking the trash can icon at the bottom right of the **Fold** window.

### Configure Check

The Configure Check dialog can be opened by selecting **Configure Check** in the flyout menu of the **Fold** window, by clicking the flyout button.

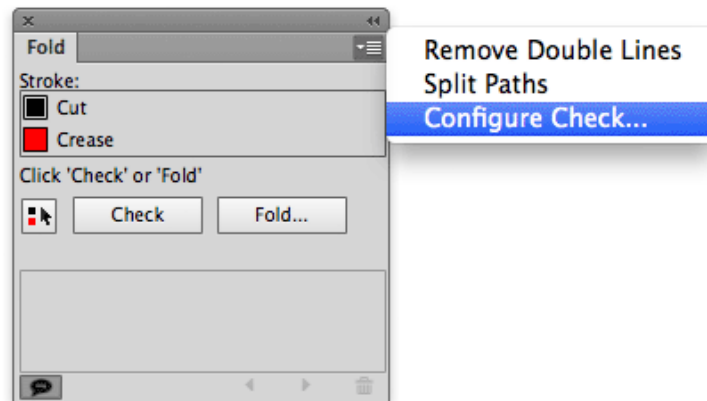

In the Configure Check dialog, you can define the **Show Gaps Smaller Than** value. Gaps larger than the **Show Gaps Smaller Than** value will not be treated as Gaps, and will thus not be shown.

### Remove Double Lines

**Remove Double Lines** in the flyout menu of the **Fold** window will remove the double lines in the selection. This will take all lines in the selection into account, irrespective of the stroke color they have. The **Remove Double Lines** function can be applied before or after assigning the **Cut** or **Crease** swatch.

1. Make the selection in which you want double lines to be removed.
2. If the **Fold** window is not open yet, select **Window > Esko > Studio Toolkit for Boxes > Show Fold Window** .
3. Select **Remove Double Lines** from the flyout menu of the **Fold** window, by clicking the flyout button.

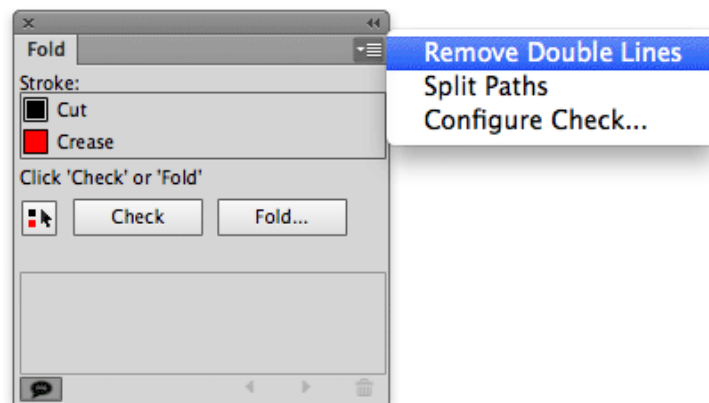

All double lines in the selection will be removed.



**Note:** Keep in mind that the **Remove Double Lines** function removes the bottom most line, regardless of what line it is. If you have already indicated which lines are cut lines and which are crease lines, make sure that only the appropriate lines are removed by moving them to the back of the canvas.



**Note:** Accepting to remove double lines automatically after running a Check works in the same way, but only affects cut and crease lines.

## Remove gaps using the Trim and Extend tool

The **Trim and Extend** tool can be used to correct gaps in the die drawing. These gaps can be found manually or by using the **Check** function.

1. Click the **Trim and Extend** tool in the toolbox.



2. Click and drag the end point you want to change.
  - Release to trim or extend the line up to the point where you release the mouse.
  - Release near or on another line to snap the end point to the intersection of both lines.

## Inaccuracies when folding the selection

When creating a fold using the Fold function in the Fold window, the die drawing is checked. Inaccuracies can be presented in different ways:

- If the cut lines are not closed to an outline, a warning message is shown. The gaps must be fixed in order to make a fold.
- Gaps can be indicated by red and green circles in the **Fold Selection** window.

- Green circles indicate gaps that will be solved with the **Automatic Correction** values in the **Fold Selection** window.
- Red circles indicate gaps that need to be solved manually.

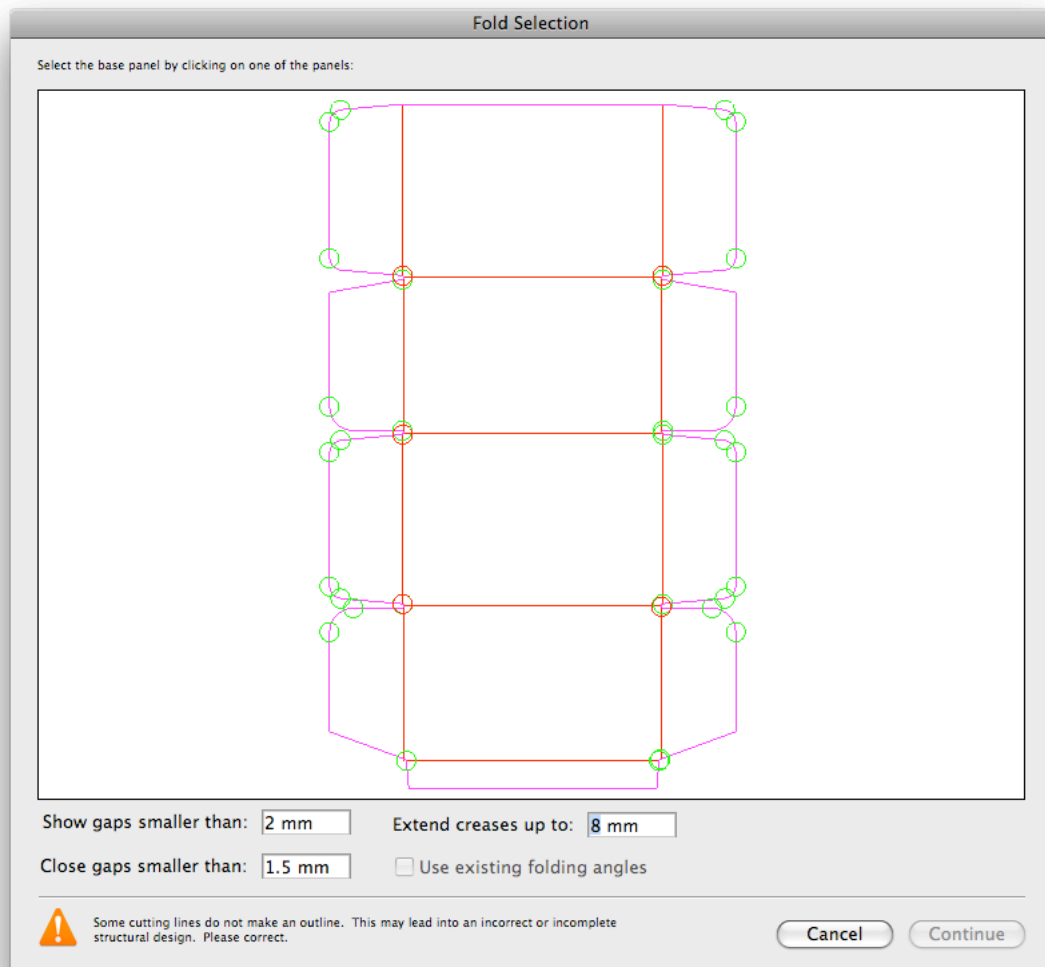

### Automatic Correction

The settings at the bottom of the Fold Selection window define what gaps are shown, and how they can be corrected automatically.

#### Show Gaps Smaller Than

In the **Fold Selection** window, you can define the **Show Gaps Smaller Than** value. Gaps larger than the **Show Gaps Smaller Than** value will not be treated as Gaps, and will thus not be shown.



**Note:** This is the same setting as the **Show Gaps Smaller Than** value in the **Configure Check**. Changing the value in the **Fold Selection** window changes it in the **Configure Check** as well, and vice versa.



### Close Gaps Smaller Than

In the **Fold Selection** window, you can define the **Close Gaps Smaller Than** value.

All gaps smaller than or equal than this value will be closed automatically. By incrementing this value, more gaps will turn green, and the fold tool will try to close them automatically. Be aware that the larger this value becomes, the more risky the outcome will be.



**Note:** The **Close Gaps Smaller Than** value can not be higher than the **Show Gaps Smaller Than** value. Setting it to a higher value will change the **Show Gaps Smaller Than** value to the same value.

### Extend Creases Up To

Gaps between Crease lines and Cut lines are common in a lot of die drawings. The **Extend Creases Up To** makes sure that these gaps are closed by extending the fold lines up to the value entered.

## 3.3.4. Fold ArtiosCAD file

Using **Fold ArtiosCAD File...** you can change the folding angles of an already folded box.



**Note:** If a placed ARD file does not contain folding angles, the plug-in cannot know how the box has to be folded. In that case 90-degree foldings are assumed on all folding lines. If the resulting shape is not the intended one, the proper folding angles need to be added to the ARD file, for example using ArtiosCAD or the **Fold ArtiosCAD File...** function described here.

1. Open the Fold Selection window:
  - Select **Window > Esko > Studio Toolkit for Boxes > Fold ArtiosCAD File...**
  - If you have the **Studio** window, you can select **Fold ArtiosCAD File...** in the flyout menu.
2. Change the fold angles as explained earlier. See [Set the folding angles](#) on page 78
3. Set the front view. See [Set the Front View](#) on page 80
4. Click **Save As** to save the result as an ArtiosCAD ARD file.
5. Define the name and location for the file.
6. You get the option to place the file directly in the document. If you click **Yes** :
  - the **Studio** window will show the folded ArtiosCAD ARD file. The new ARD file will be placed next to already placed Structural Design files.
  - the selected items will be moved to a locked layer.
7. You can also use the ArtiosCAD ARD file in Studio Toolkit.

## 3.3.5. Tips & Tricks: create a cutout window in a box

If you want to create a cutout window in an existing ARD box, you can create the shape and add it to the ARD file.

1. Open or place an ARD file.

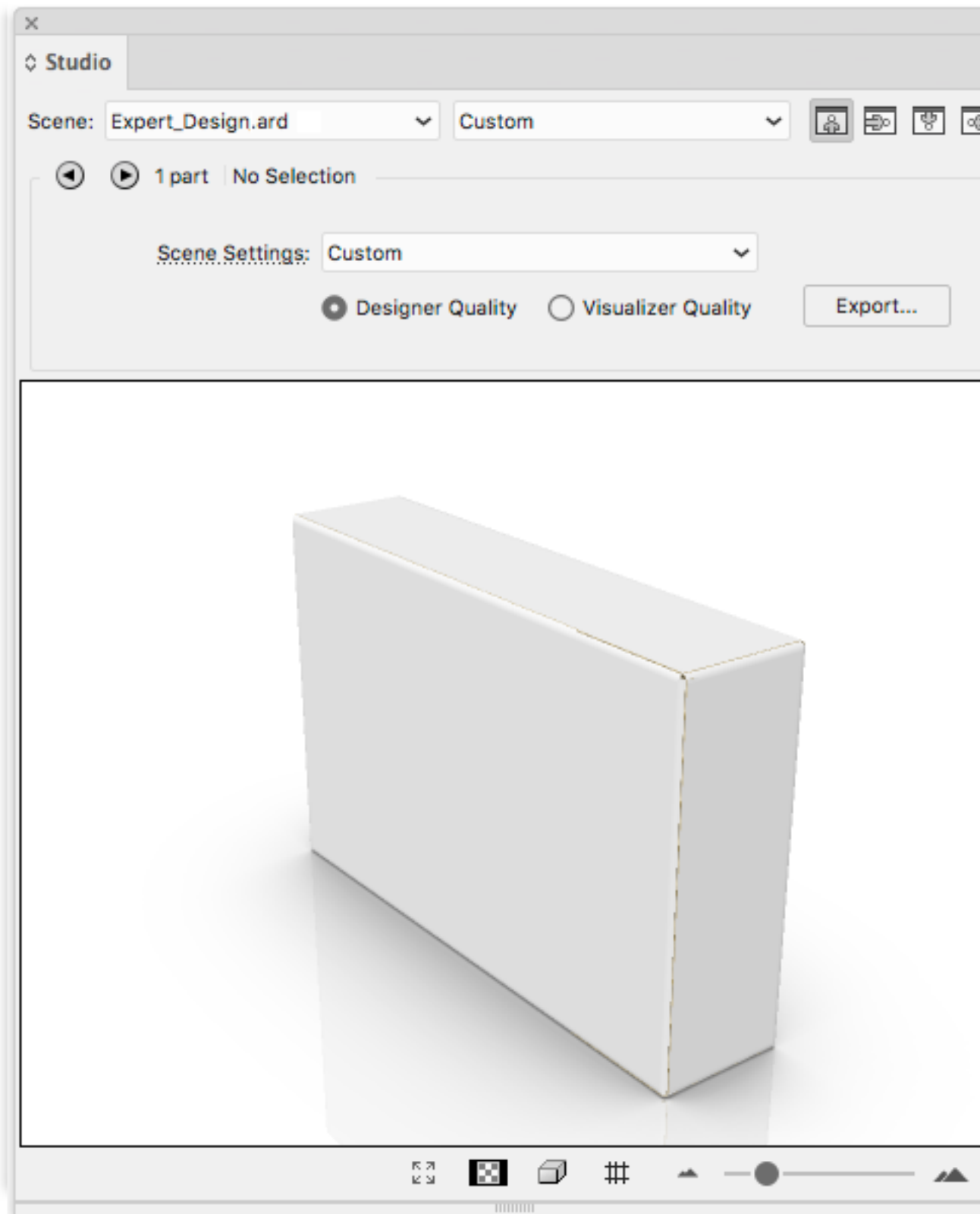

2. Create and select the cutout shape that you want to add to the ArtiosCAD file.

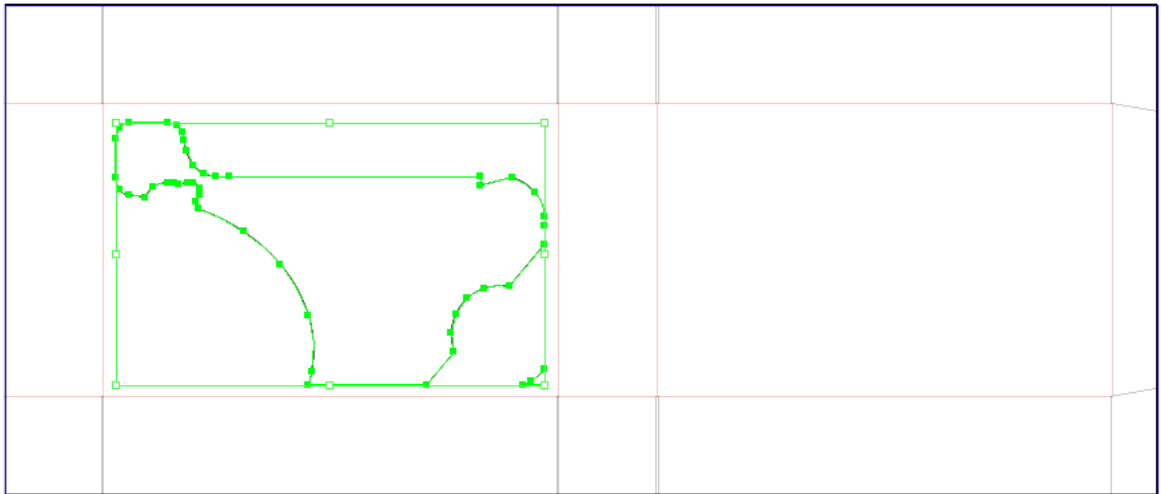

3. Choose **File > Structural Design > Export Selected Objects to ArtiosCAD File**.

The **Export Selected Objects to ArtiosCAD File** appears.

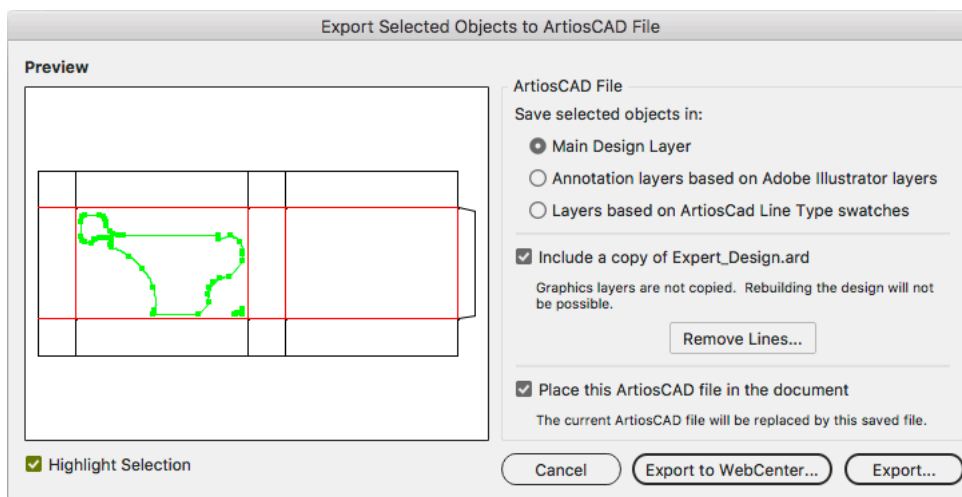

4. Select the following options

- Save the selected objects in the Main Design Layer.
- Include a copy of the original ARD file.
- Place this ArtiosCAD file in the document.

5. Click **Save As...**

The selected objects are saved in the **Main Design Layer**. They get the cut line type (which is the default if you did not specify a swatch with as name an ArtiosCAD line type). Apart from the selected objects, the original ARD file is copied in the resulting ARD file and the resulting ARD file is immediately placed in the Illustrator document.

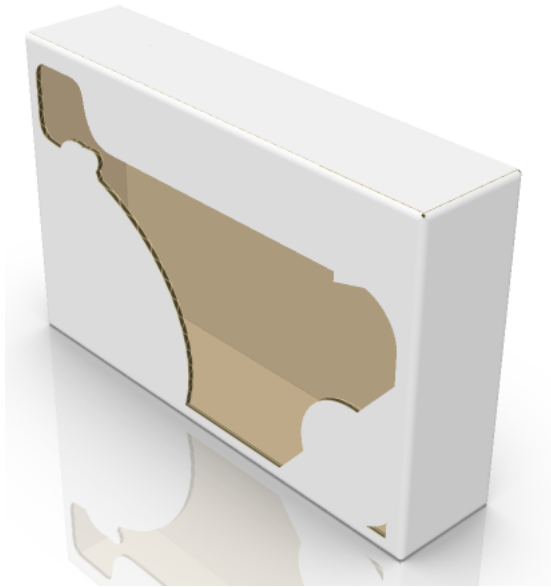

### 3.4. Create a label

There are three different ways to create labels in Studio.

	Where	Extra functionality
1. Front, Back and Wrap Around	Studio Toolkit	<ul style="list-style-type: none"> <li>• Die Cut path</li> <li>• Labels can be edited</li> </ul>
2. Freeform Label	Studio Toolkit	<ul style="list-style-type: none"> <li>• Labels can be edited</li> </ul>
3. Revolved shape	Adobe Illustrator	<ul style="list-style-type: none"> <li>• Conical Warping</li> </ul>

#### 1. Front, Back and Wrap Around Labels

If you have an existing 3D object (e.g. a collada file of a bottle, can, jar, ...) you can import it in Studio Toolkit (see [Importing Shapes, Images or Paths](#) on page 53) and add a cylindrical or conical label. See [Front, Back and Wrap Around Labels](#) on page 89

The result will be a Collada file that you can use in Studio Essentials in Adobe Illustrator. It will contain a Printable Part for every label.

If you are working with a Front, Back or Wrap Around label, you can use a Die Cut path to refine the die cut shape of the label. See [Using a Path as a Die Cut](#) on page 91



**Note:** Conical warping is not available on these labels. If you have a Studio Toolkit for Shrink Sleeves license, you can however use **Predistort**.

## 2. Freeform Labels

If you have an existing 3D object (e.g. a collada file of a bottle, can, jar, ...) you can import it in Studio Toolkit (see [Importing Shapes, Images or Paths](#) on page 53) and brush a bespoke **Freeform Label** anywhere on the container. See [Creating a Freeform Label](#) on page 93

The result will be a Collada file that you can use in Studio Essentials in Adobe Illustrator. It will contain a Printable Part for every label.

## 3. Revolved Shape

If you don't have an existing 3D shape, you can create a round shape by revolving a profile path. See [Creating a revolved shape with labels](#) on page 95

During this procedure you can immediately add a Front, Back, Top, Bottom or Roll around label.

When working on one of these labels, you can apply **Conical warping**. See [Conical Warp](#) on page 141



**Note:** You can also use the **Revolve** function to create the shape (e.g. of a bottle), save this shape as a collada file, open it in Studio Toolkit and apply a **Front, Back and Wrap Around Labels** or **Freeform Label**.

### 3.4.1. Front, Back and Wrap Around Labels

Front Labels, Back Labels and Wrap Around Labels are three similar types of labels that can easily be created and controlled in Studio Toolkit.

1. Import the shape into Studio Toolkit. See [Importing Shapes, Images or Paths](#) on page 53
2. Select the shape on which you want to add the label
- 3.



Click the **Add Label** button **Add Label** and select **Front Label, Back Label** or **Wrap Around Label**.

A default Front Label, Back Label or Wrap Around Label is created.

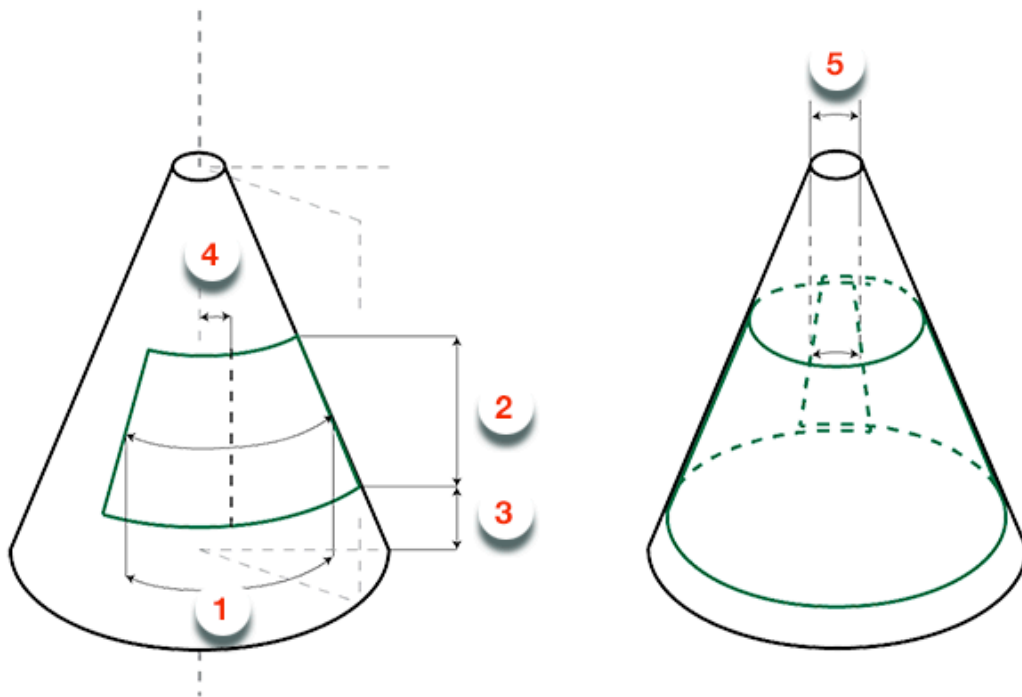

4. You can set the **Dimensions** and **Position**, either numerically in the **Settings** panel on the right, or manually by dragging the handles on the label.
- For a Front Label And Back Label, you can set the **Width** (1) and **Height** (2). For a Wrap Around Label, you can set the **Overlap** (5), **Overlap direction** and **Height** (2). The actual width is defined by the size of the shape and the positioning of the label.
  - Set the **Base** (3) to define the distance between the bottom of the object and the bottom of the label
  - Set the **Off-Center** (4) to shift the label from the center of the shape, either the front (for Front and Wrap Around labels) or back (for Back labels) center
  - Drag one of the four handles on the label edges (in 3D view) to resize the label. Hold the Alt key to keep the label centered.
  - Drag the handle in the middle of the label to move it. Hold the Shift key to only move it vertically or horizontally.
5. Using the **Visualization offset** you can change the distance between the label and the shape in the 3D preview without changing the 2D technical drawing. For shapes that are not perfectly cylindrical or conical, this can avoid flickering or intersections between the label and the shape.
6. Set the shape of the label to **Cylindrical** or **Conical**
- For Conical labels, the horizontal sizes Width (1) and Overlap (5) are measured half way the height of the label.
- The Height (2) of a label is measured vertically in 3D, so for conical labels, the actual height is slightly bigger.
7. If necessary, repeat the previous steps to add another label
- A 2D tab will be added for every label you create.

The result will be a Collada file that you can use in Studio Essentials in Adobe Illustrator. It will contain a Printable Part for every label.

You can use a Die Cut path to refine the die cut shape of the label. See [Using a Path as a Die Cut](#) on page 91

## Using a Path as a Die Cut

If you create a Front, Back or Wrap Around label, the shape of your label will always be rectangular. You can however use a **Die Cut Path** to cut away parts of the label.

A Die Cut path can only be used on a Front Label, Back Label or Wrap Around Label. Other object types are not supported. The Die Cut path should overlap with the object in the 2D tab, and the **Cut along this path** option should be enabled.

- If you want to start from a Label in Studio Toolkit:
  - a) Add a Front, Back or Wrap around label in Studio Toolkit. See [Front, Back and Wrap Around Labels](#) on page 89
  - b) Set the label size and position, so that the label is large enough to completely include the die cut.
  - c) Save as a collada file. See [Saving and opening Collada files](#) on page 52
  - d) In Adobe Illustrator, use **File > Structural Design > Place File** and select the Collada file you saved. If necessary, select the correct printable part, e.g. "Front Label".
  - e) Create the Die Cut path in Adobe Illustrator, using the label shape as a visual guide.
  - f) Select the path.
  - g) From the fly-out menu in the Studio window, select **Send Path to Toolkit**.  
The path becomes available in the 2D tab in Studio Toolkit, and is automatically set as Die Cut path.
- If you want to start from an existing path in Adobe Illustrator:
  - a) In Studio Toolkit, open the document in Studio Toolkit you want to add the Die Cut to.
  - b) In Adobe Illustrator, select the path you want to use.
  - c) From the fly-out menu in the Studio window, select **Send Path to Toolkit**.  
The path becomes available in the 2D tab in Studio Toolkit, and is automatically set as Die Cut path.
  - d) Add a Front, Back or Wrap around label in Studio Toolkit. See [Front, Back and Wrap Around Labels](#) on page 89
  - e) Set the label size and position, so that the label is large enough to completely include the die cut.
- After these steps, you have a shape with a Label and a Die Cut path, which you can save as a collada file and use in Adobe Illustrator to apply graphics on.

In Adobe Illustrator:

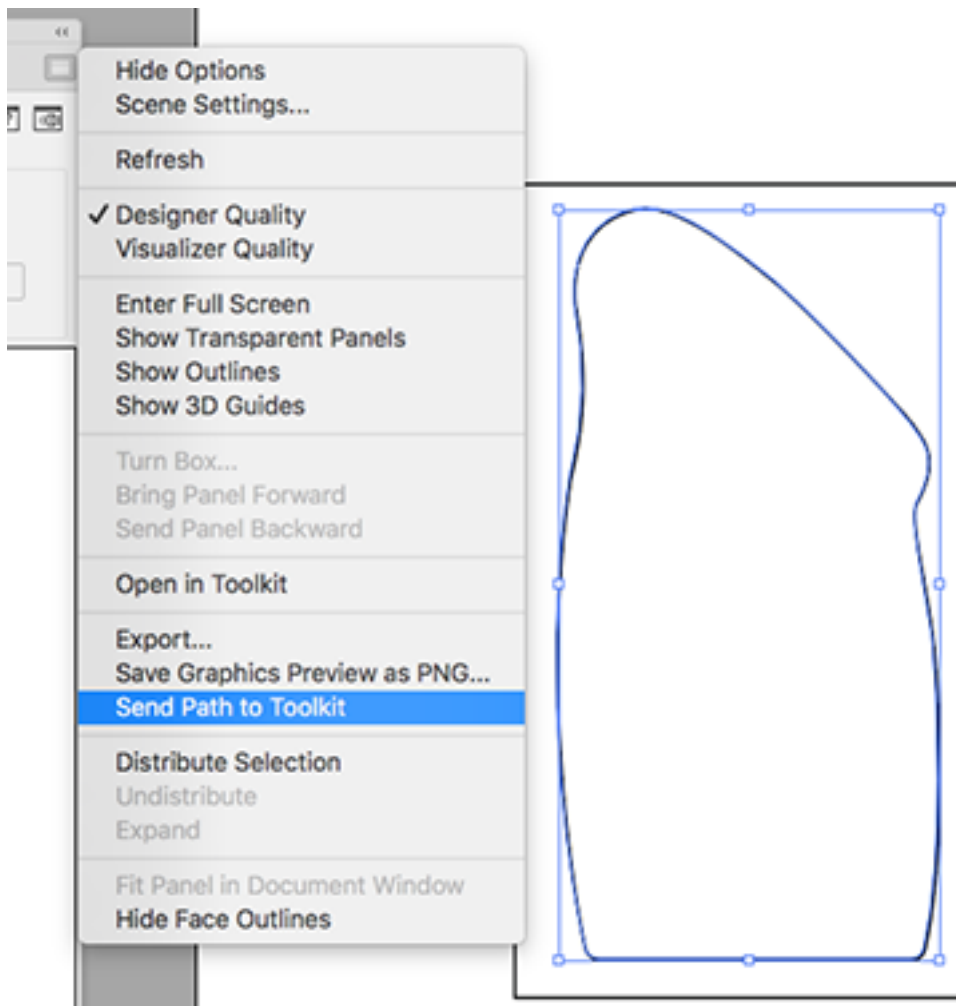

In Studio Toolkit, both 2D view (left) and 3D view (right):

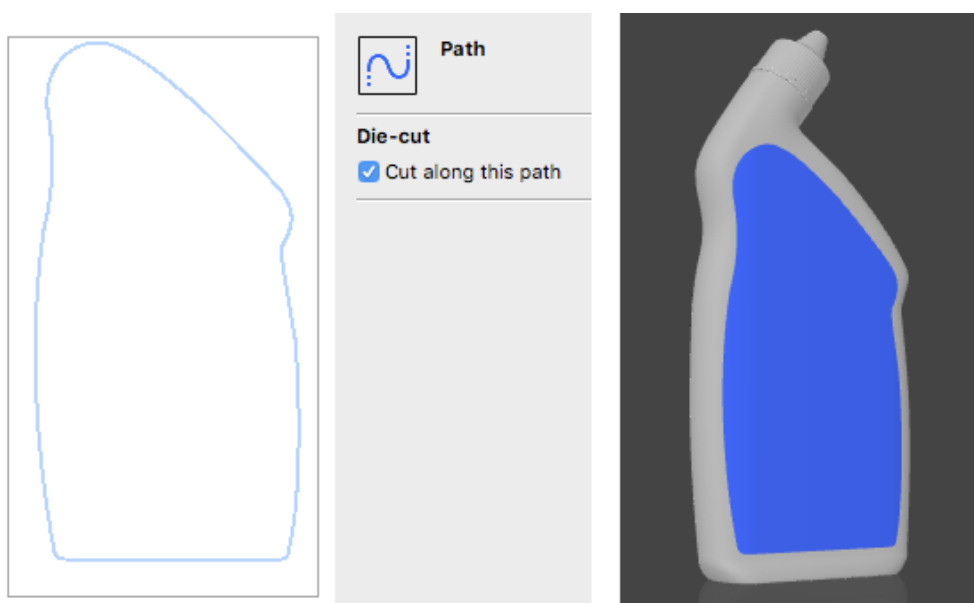



### 3.4.2. Creating a Freeform Label

Using the **Freeform Label**, you can "brush" a label on an existing shape (collada file, obj, ...).

1. Import the shape into Studio Toolkit. See [Importing Shapes, Images or Paths](#) on page 53
2. Select the shape on which you want to add the label

3.



Click the **Add Label** button and select **Freeform Label**.  
The shape will be represented with all the triangles that it consists of.

4. Draw your label.

- If you click and drag from inside the label, or if no label exists yet, your cursor will be yellow, and

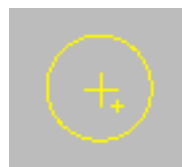

anything you brush will **add** the triangles to the label.

- If you click and drag from outside the label, your cursor will be blue, and anything you brush will



**remove** it from the label.

- Using the slider at the top of the window, you can define the **Brush size**. You can also change the brush size using the shortcuts [ and ].



**Note:** The label you draw can NOT contain any holes. You won't be able to add or remove areas that would result in a hole in the label.

5. To stop drawing the label, click the **Done** button at the top of the window. You can also click the **Add Label** button again, or click the **Modify Area** button in the pane on the right.



**Note:** After clicking **Done**, it is advisable to check the **Maximum Distortion**. See [Distortion](#) on page 94



**Tip:**

- If you received a curve representing the shape of the label (i.e. a die-cut in Illustrator), you can save this as a .PNG or .JPG file, and import it onto the 2D view of the label to check if the brushed area has the right size and shape. See [Using graphic files](#) on page 54
- If the edges of your label are too rough, and you have Studio Visualizer, you can select a slightly oversized area and use the **Die Cut** operation in Studio Visualizer to trim away the unwanted parts. Alternatively, you can consider using a Front, Back or Wrap Around label in combination with a Die Cut path. See [Front, Back and Wrap Around Labels](#) on page 89 and [Using a Path as a Die Cut](#) on page 91

6. If necessary, repeat the previous steps to add another label

A 2D tab will be added for every label you create.

The result will be a Collada file that you can use in Studio Essentials in Adobe Illustrator. It will contain a Printable Part for every label.

### Modifying a Freeform Label

To modify a label you drew earlier:

1. Select the label
2. In the pane at the right, click the **Modify Area** button.



**Note:** If you would click the **Add Label** button, you would create a new label instead.

3. Modify the area by adding or removing to the label.

### Distortion

If a label is selected in Studio Toolkit (i.e. not while you are drawing it, but after you clicked **Done**), the pane at the right will show the **Maximum distortion**.

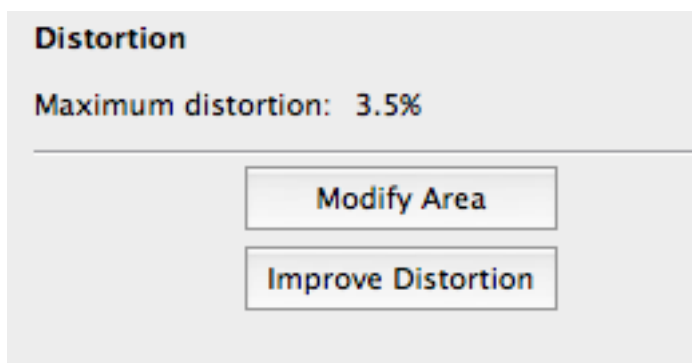

In Studio Toolkit, you can draw a (virtual) label on any surface. However, a real adhesive label (pressure-sensitive label) can not be applied to just any area of a container. It depends on the curving: on surfaces with too much curving, a real label would either have a stretch or wrinkle to fit the shape.

This is shown in the **Maximum distortion** value. A high value means that the virtual label is stretched or wrinkled.

If the distortion is higher than 3% and if you need accurate artwork placement, we suggest you try the **Improve Distortion** function.

By clicking the **Improve Distortion** button, you can try to change the way the 3D label is unfolded. The process tries to lower the Maximum distortion by distributing the distortion over the complete label. The improvement will continue until you click the **Done** button, or until a message "Reached the optimal distortion" is given.

If after **Improve Distortion** you still have a distortion value that is too high, you have probably selected an area that is not suited for a label.



**Note:** Modifying the area will reset the improvement.

### Tips&Tricks: trim a Freeform label

By drawing a label on a 3D shape, it is rarely possible to draw the exact shape of label you want to add.

As your printable part is the only place you can place artwork, the label drawn should be bigger than the label you want to place on your shape.

In Adobe Illustrator, you can then use a **Die Cut operation** to trim away the excess material in the 3d Preview.

For more information on Die Cut operations, see [Tips&Tricks: Using a Diecut operation](#) on page 173

The example underneath shows the shape with the label drawn in Studio Toolkit (1), the Studio preview in Designer quality without die cutting (2) and in Visualizer quality using the Die Cut operation (3).



Alternatively, you can consider using a Front, Back or Wrap Around label in combination with a Die Cut path. See [Front, Back and Wrap Around Labels](#) on page 89 and [Using a Path as a Die Cut](#) on page 91

### 3.4.3. Creating a revolved shape with labels

In Studio Essentials, you can create a shape (e.g. bottles) based on a profile path, and add labels to it.

There are two ways to create a revolved shape:

- Revolve the shape and add labels in Adobe Illustrator. See [Revolve a profile and Add Labels in Adobe Illustrator](#) on page 99
- Revolve the shape in Studio Toolkit, and add labels using the Studio Toolkit functionality. See [Revolve a profile and Add Labels in Studio Toolkit](#) on page 107

The principle of revolving a path is similar, but the resulting labels behave differently:

- When working on a label created on a revolved shape in Adobe Illustrator, you can apply **Conical Warp**. See [Conical Warp](#) on page 141
- When working on a Front, Back or Wrap Around label created on a revolved shape in Studio Toolkit, you can use a path as a Die Cut. See [Using a Path as a Die Cut](#) on page 91

### Create a profile path

The first step in creating a revolved shape is creating or selecting the Illustrator paths to be used as profile paths.

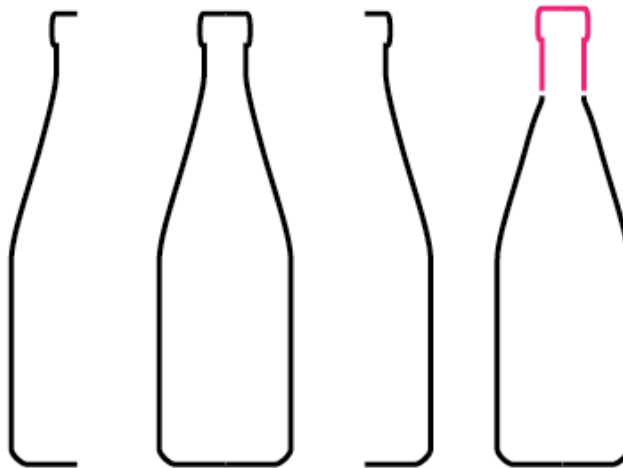

Studio supports half profiles, full profiles and multi-part profiles (based on multiple paths). Multi-part profiles can be used to set different materials for different parts (for example the bottle and the cap).

It is important to connect paths that can share the same material. If the path is not connected or needs cleanup, you can use the **Connect and Clean** function for this.

In the example below, the shape consists of two parts. The bottle itself which will have glass as material and the cap which will be metal.

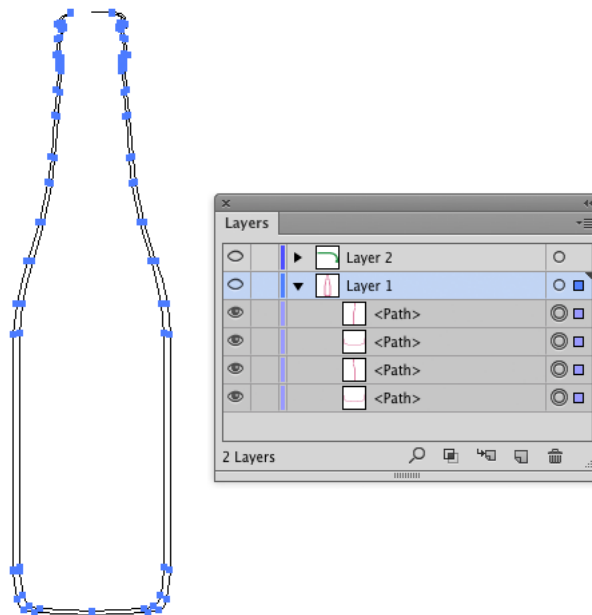

1. Select the paths that make up the bottle. In the example above, the profile of the bottle consists of three paths.
2. Select **Window > Esko > Studio Toolkit for Labels > Connect and Clean** . This will create a layer called "PROFILE" that contains the connected path.

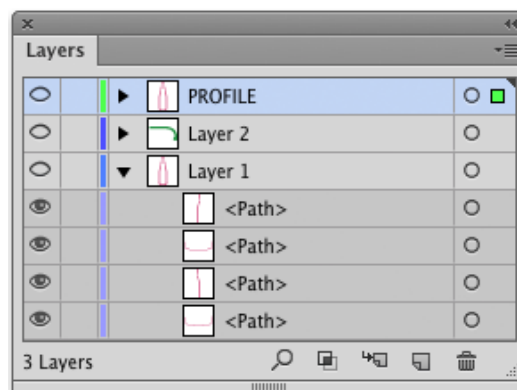

3. Select this path and the path making up the cap, and revolve it. See [Revolve a profile and Add Labels in Adobe Illustrator](#) on page 99 or [Revolve a profile and Add Labels in Studio Toolkit](#) on page 107

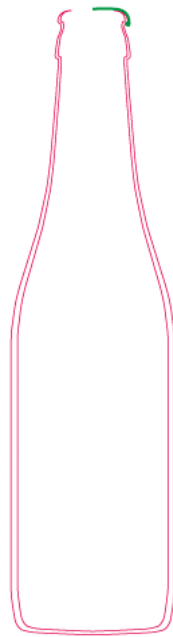

**Create a profile path for liquids**

When using Ray Tracing quality, you can model a liquid material inside a container. The example underneath contains the path for the bottle (red), the cap (blue) and the liquid (green)

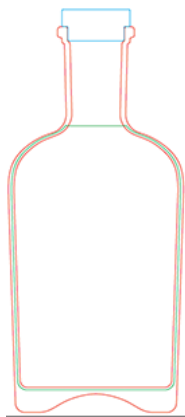

- Make sure there is an overlap at the boundaries between the liquid and the container. This is required to ensure a physically correct rendering. The actual area of overlap doesn't matter, and will be rendered as container material (e.g. glass).
- All clear parts (glass, liquid, ...) need to be closed surfaces.



**Limitation:** When choosing Cloudy Plastic as container material, the liquid will be rendered black. As a workaround you can choose a different material for the liquid (e.g. plastic), since most of the detail of the liquid will be lost when viewed through the cloudy plastic. Alternatively you can leave a small gap in between the liquid and the container.

## Revolve a profile and Add Labels in Adobe Illustrator

**Revolve and Add Labels**, the dialog to create shapes and labels, can be opened from **Window > Esko > Studio Toolkit for Labels > Revolve and Add Labels...**

### Revolve

The first step in the Revolve and Add Labels procedure is to create the shape by revolving a profile path.

1. Select one or more Illustrator paths to be used as profile paths.
2. Select **Window > Esko > Studio Toolkit for Labels > Revolve and Add Labels...**

The **Revolve and Add Labels** dialog is opened.

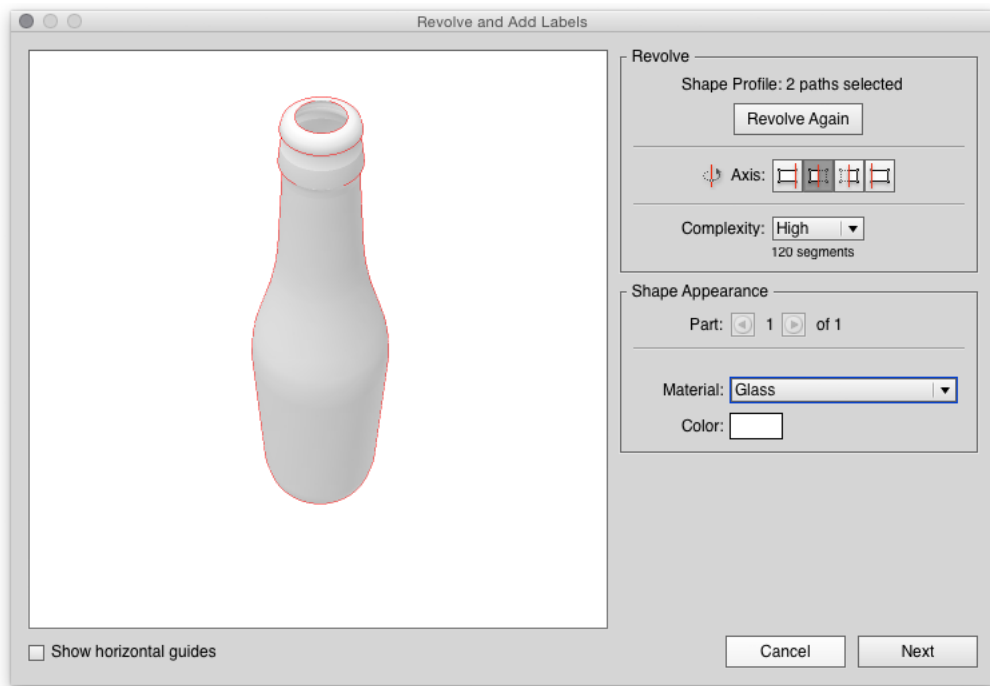

On the left is a 3D rendering of the result. You can click and drag to change the viewing angle.

3. Set the **axis** to be used for the revolution. There are four options: you can set the axis completely on the left or right of the path (1), or through the middle, taking the left or the right side of the design (2).

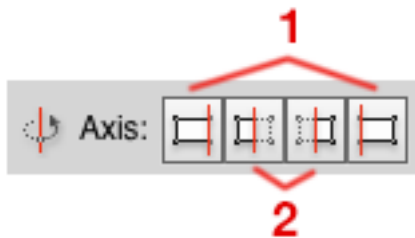

In the example profile path shown earlier, only the right half of the bottle cap is drawn. By choosing the axis through the middle and taking the left side of the design, you can revolve the bottle without the cap.



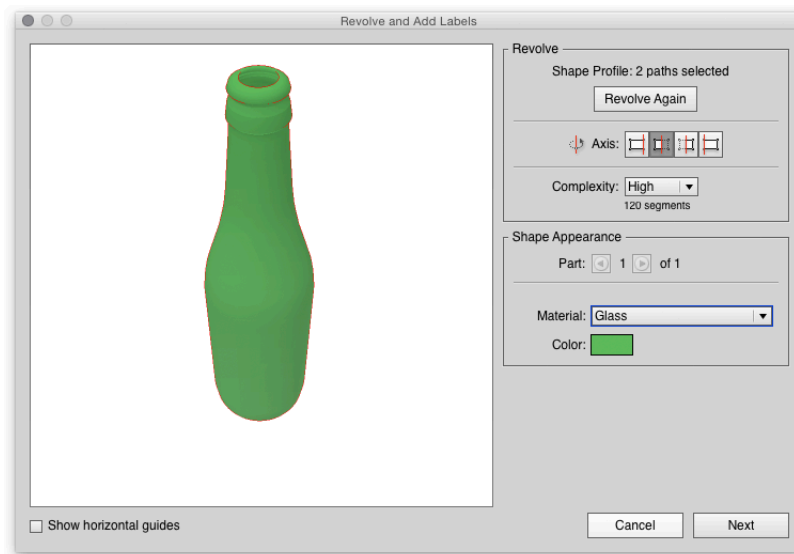

By revolving the right side of the design, you can revolve the bottle with the cap.

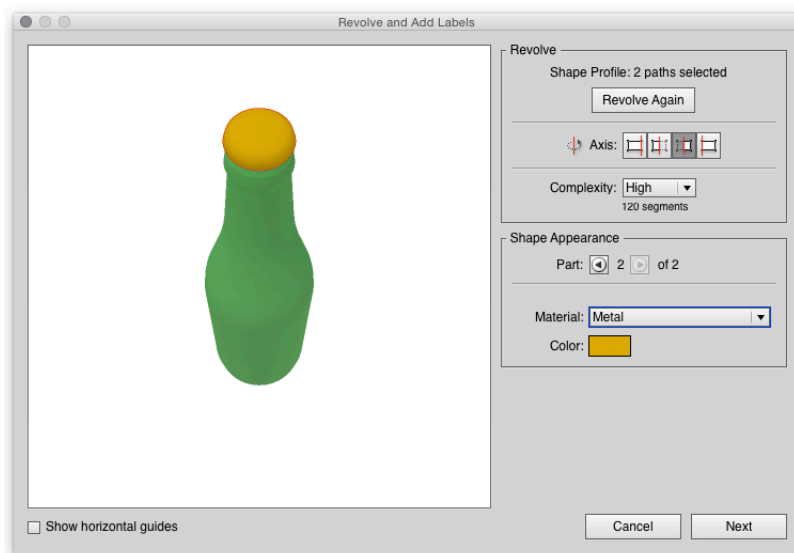

The same axis will be used for all paths of a multi-part profile.

4. Set the **Complexity** of the model. The higher the complexity, the smoother the revolved model will be. This setting only controls the horizontal complexity of the model. To modify the vertical complexity of the shape, you can increase or decrease the number of anchor points on the profile curves, using the Adobe Illustrator tools, such as **Object > Path > Add Anchor Points**



**Note:** A higher Complexity results in a larger Collada file. If you create a shape that will be repeated and used in a larger scene, you might want to keep complexity low(er).

5. For each of the parts, define the **Material** . You can choose Matt Plastic, Glossy Plastic, Clear Plastic, Glass or Metal.



**Note:**

Transparency of e.g. clear plastic or glass will only be visible in the Studio window using **Visualizer Quality**. See [Visualizer Quality](#) on page 143

6. If necessary, click the **Color** field to define the color for the material.
7. Click **Next** .

**Add Labels**

In this second step, you can add the labels.



**Note:**

If you do not want to add a label, just click 'Save as' to save the result as a Collada file. Note that this collada file will not contain a Printable Part. You can however open the shape in Studio Toolkit and add a label there, or add a shrink sleeve.

The **Labels** list shows all defined labels.

1. Add a label.

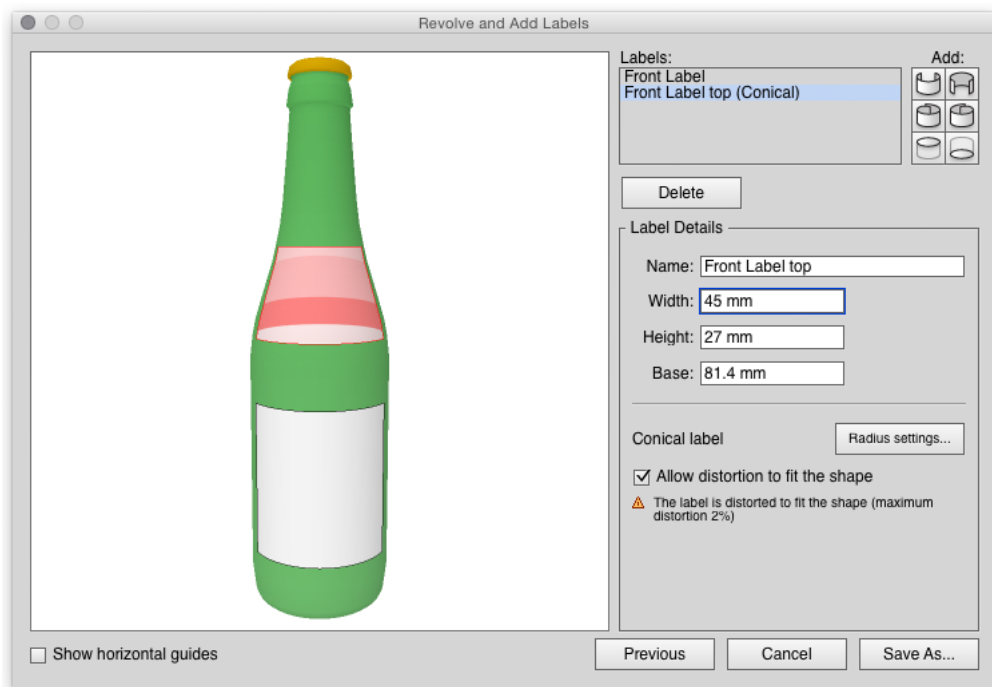

There are 6 types of labels to choose from:

- Front label
- Back label
- Roll around label (right/end over left/begin)

- Roll around label (left/begin over right/end)
  - Top label
  - Bottom label
2. Select the label by clicking inside the label to change the properties of the label.
  3. Enter the **name** for the label.  
The default name is based on the selected type, such as "Front Label" or "Round label".
  4. Define the **width** for Front or Back labels. For conical labels, the width is measured at mid height.
  5. Define the **Overlap** for Roll-around labels. The overlap is always centered at the backside.
  6. Set the **height** for the Front, Back or Roll-around label.



**Note:**

You can also change the height of a label interactively by dragging the handles in the 3D view

7. Set the **Radius** for a Top or Bottom label
8. Check the **Radius Settings**

The Revolve and Add Labels dialog will show if the label is cylindrical or conical.

Every label except Top and Bottom has a top radius and a bottom radius. By default, both radius are calculated automatically from the position of the label and the size of the container. If these are equal, the label is cylindrical. If they are different, the label is conical.

To manually change the Radius settings:

- a) Click the **Radius Settings** button  
The Radius Settings dialog will open
- b) Disable **Calculate radius automatically from shape**
- c) Enter the Top of Label and the Bottom of Label radius
- d) Click **OK**



**Note:**

The specified radius settings are used for the 2D calculations. Yet the label in 3D still fits perfectly to the container shape.

9. Check the Distortion warning.  
See [Distortion](#) on page 105 for more information
10. Click **Save As** to save the result as a Collada file.
11. Define the name and location for the file.
12. You get the option to place the file directly in the document.  
If you click **Yes** :
  - the **Studio** window will show the Collada file, replacing any earlier ARD or Collada files.
  - the selected items will be moved to a locked layer.

- If you added more than one label, there will be multiple printable parts in the Collada file. In that case, a message dialog will show up, allowing to select one printable part from a list with the names of all printable parts. The selected printable part will be placed in the Illustrator file. For more information on working with multiple Printable Parts, see [Scenes and Multiple Documents](#) on page 151

**13.** Add artwork to the labels.

When using Visualizer Quality in Studio Designer, the Collada file could look like this in the Studio window:



You can also use the Collada file in Studio Toolkit.



**Note:**

Please note that you can also change the height or the position of your label by dragging the handles on the label in the 3D view. Even more, if you know what the height of your label needs to be in the Illustrator document view, just add two horizontal guides to the Illustrator document view and toggle on 'Show Horizontal Guides' in the Revolve dialog. You now can drag the top and bottom of your label to the horizontal guides.

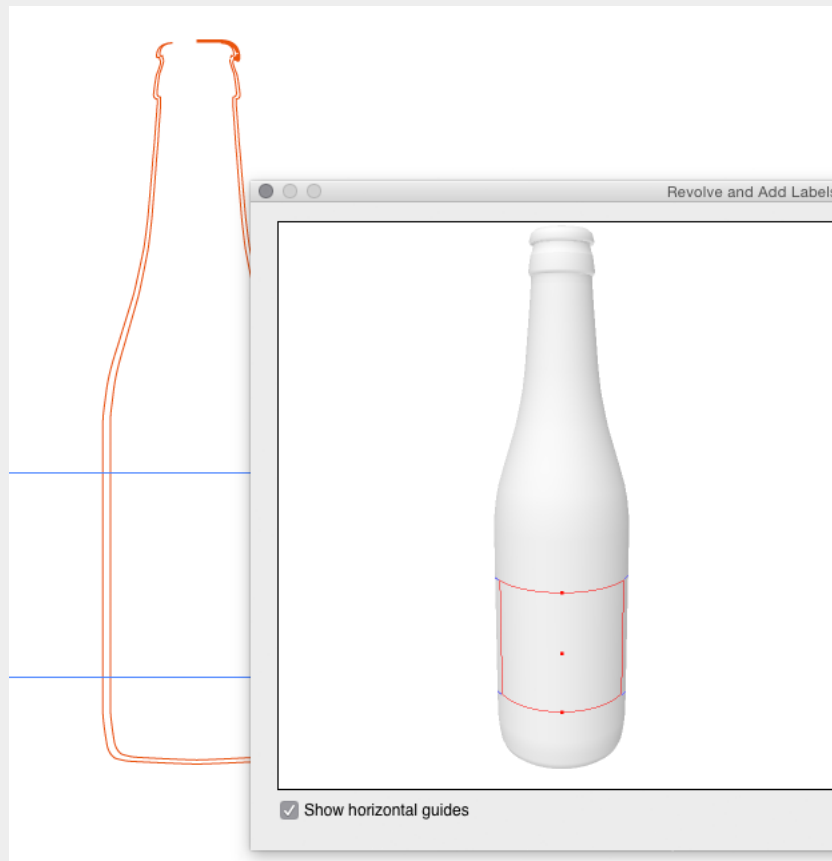

**Distortion**

Adhesive labels can always be folded to cylinders or cones, but on many other shapes, some distortion (stretch or wrinkling) is required to make the label fit. A typical label substrate only allows for very small amounts of distortion.

The software allows distortion up to 3%. If there is distortion below 3%, a warning will be shown in the Revolve and Add Labels dialog, and the distorted areas are highlighted.

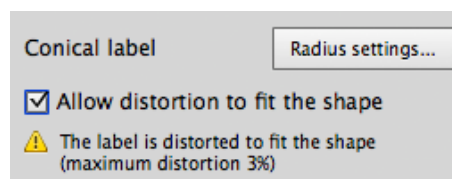

You can disable the **Allow distortion to fit the shape** option to avoid distortion of your label.

### Tips&Tricks: Die cut operation on a label

If you create a label on a revolved profile in Adobe Illustrator, the shape of your label will always be rectangular. You can however use a **Die Cut operation** to cut away parts of the label. See also [Tips&Tricks: Using a Diecut operation](#) on page 173

The example underneath shows the Studio preview without die cutting and in Visualizer quality using the Die Cut operation.



Alternatively, you can consider using a Front, Back or Wrap Around label in combination with a Die Cut path. See [Front, Back and Wrap Around Labels](#) on page 89 and [Using a Path as a Die Cut](#) on page 91

### Revolve a profile and Add Labels in Studio Toolkit

To create a revolved shape in Studio Toolkit, you create the profile path in Adobe Illustrator (see [Create a profile path](#) on page 96) and revolve the path in Studio Toolkit.

1. Select the path(s) you want to revolve
2. Choose **Revolve path in Toolkit** in the fly-out menu of the Studio window  
The Studio Toolkit application will open
3. Select the **axis** to revolve around.

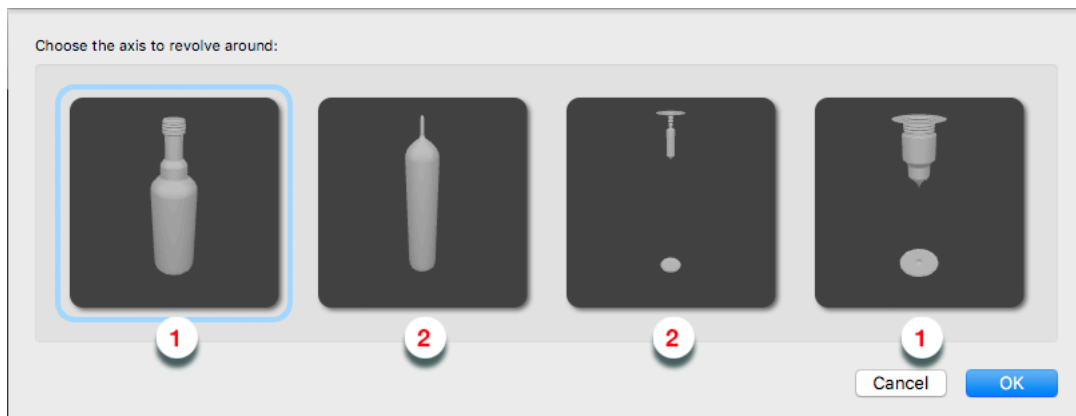

There are four options: you can set the axis completely on the left or right of the path (1), or through the middle, taking the left or the right side of the design (2).

Studio Toolkit will show a preview of the result, and by default select the most likely option.

4. Click **OK**
5. For every part of the revolved object (based on the different paths in the profile) you can change the settings
  - In **Geometry** you can set the **Quality**. The higher the quality, the smoother the revolved model will be. This setting controls both the horizontal and vertical complexity of the shape. A high quality will follow the profile curves more closely, but will result in a higher number of triangles.
  - In **Appearance** you can set the **Material** and **Color**.

The resulting 3D shape can be handled as any other 3D shape in Studio Toolkit: you can add a freeform label, a Front, Back or Wrap Around label, etc.

When using a Front, Back, or Wrap Around label, you can use a path as a Die Cut. See [Using a Path as a Die Cut](#) on page 91.

See:

- [Front, Back and Wrap Around Labels](#) on page 89
- [Creating a Freeform Label](#) on page 93

#### 3.4.4. Creating a label from Curves

In case you have the die lines of a (conical) label, but no 3D model of the corresponding container, you can create a 3D model of only the label, using a combination of ArtPro+ and Studio Toolkit.

This can be used e.g. to create a 3D shape of a complex conically warped label in an in-mould-label printing environment.

1. In ArtPro+, create the Label Outline Curves based on a technical drawing of the Source Grid.

The Label Outline Curves should be two separate smooth, open, non-intersecting paths that follow the top and bottom edges of the label. Only curves that bend in a single direction are supported.

Below an example of a technical drawing, and the two selected Label Outline Curves.

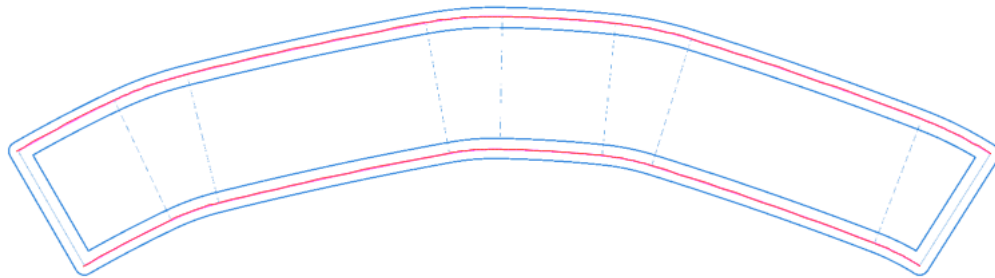

2. With the Label Outline Curves selected, choose **Object > Path > Create Label from Curves in Toolkit**. A "Label from Curves" object is created in Studio Toolkit.

- In case Studio Toolkit was not running, the application will be started automatically.
- If Studio Toolkit was running and had an open document, the newly created object will be added in the open document.
- A 2D tab is added containing the connected top and bottom curves, and the folded label is shown in the 3D tab.
- The convex side of the label is considered to be the front side

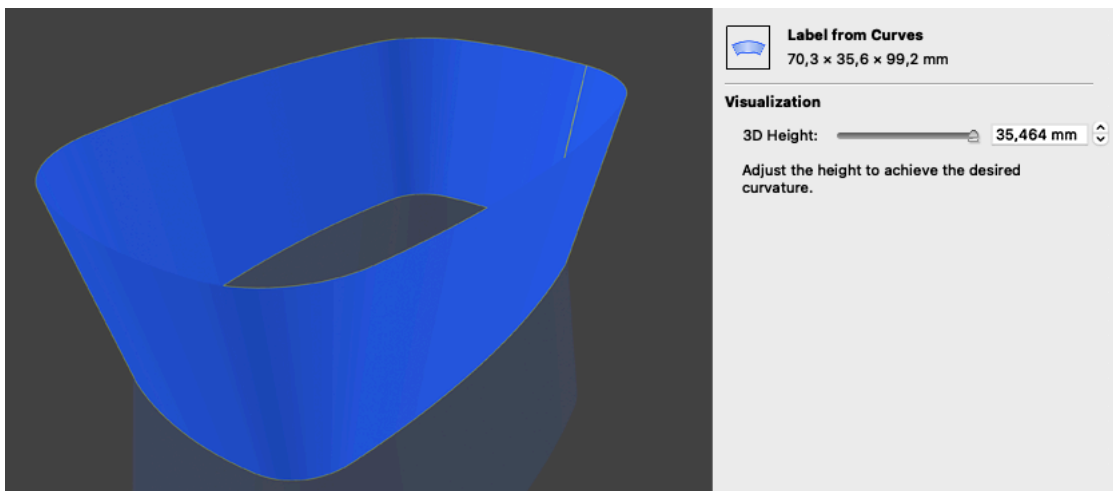

3. Set the 3D Height, i.e. the height along the vertical axis. This defines the curvature of the folded label.

When the input field is active, you can use the arrow keys to adjust the height by 0.001mm increments (or 0.01mm when holding the shift key. Due to physical constraints, the 3D height is limited.



4. You can then save the label as a Collada file, and place it e.g. in ArtPro+ to get a 3D preview of your label.



For more information on ArtPro+, we refer to the [ArtPro+ Documentation](#)

## 3.5. Browse Shapes

---

The **Shapes** Store is a constantly growing online collection of quality 3D models in Collada file format. If you have a license for Studio, you can download all available models.

To open the **Shapes** Store, select **File > Structural Design > Browse Shapes...**

After entering your Esko ID, the Shapes Browser will open.

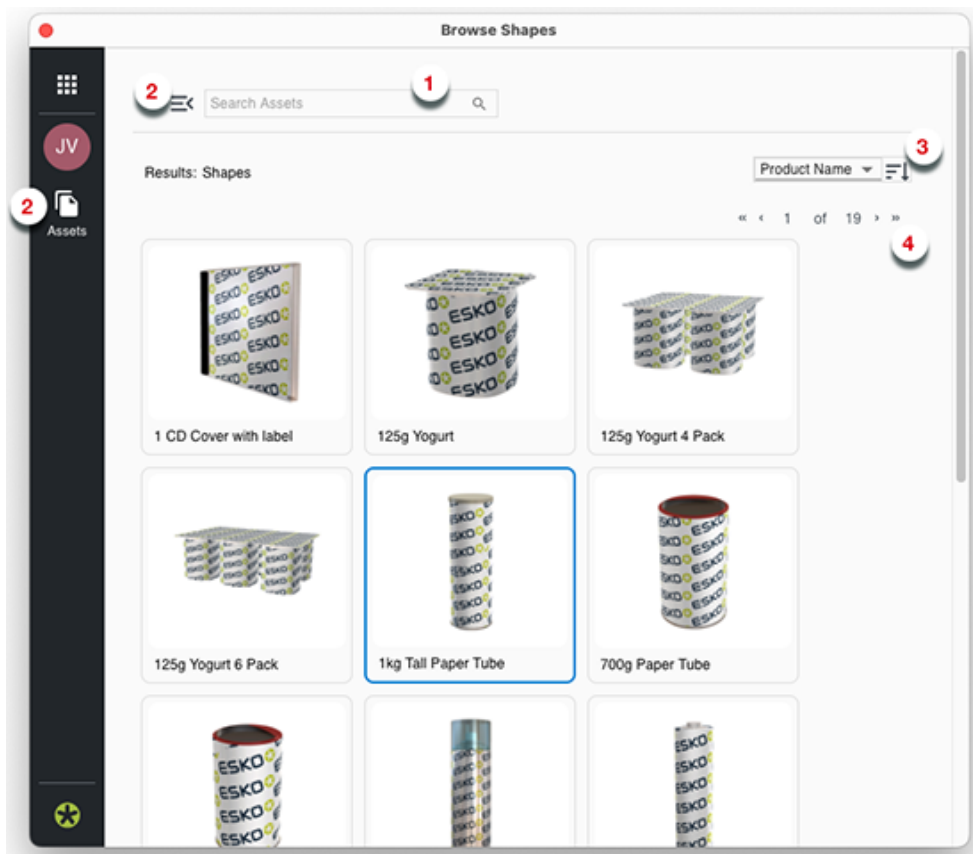

There are different tools to find the shape you want:

1. You can enter a name or a part of a name in the search bar
2. You can open the **Assets** bar by clicking the Assets button, either in the side bar or next to the search bar. In the **Assets** bar you can filter the shapes based on their type: Metal containers, paper & board, etc.
3. You can sort the results based on their Product name or their modification date, descending or ascending
4. You can browse through the different pages using the arrows.

Once you have found the shape you need, select it to see its details, and click the **Download** button.

Select the folder where the Shapes file should be downloaded.

After download, you can choose how to handle the newly downloaded file:

1. Place the shape in the current document.
2. Open in a new document: a new document is opened, and the shape is placed. The new document will have the size of the Printable Part of the shape.
3. Just save the document.

## 4. Step 2: Applying and adjusting artwork

---

To bring the Structural Design and the graphic design together, a Structural Design file can be placed or opened. You can place Structural Design files in Illustrator with the **Esko Data Exchange** plug-in, which can be downloaded for free from the Esko website and which is also installed when installing Studio Essentials.

With the Esko Data Exchange plug-in the 2D lines (such as cut and crease lines) can be aligned with the graphics. You can find the Esko Data Exchange documentation at <https://www.esko.com/en/Support/Product?id=Esko%20Data%20Exchange%20for%20Adobe%20Illustrator> or open it from within Illustrator, by choosing **Help > Esko > Esko Help > Esko Data Exchange**.

**Note:**

You can also load a Structural Design file as an extra scene in the Studio window. Each part of the scene can get its graphics from another Illustrator document. See [Scenes and Multiple Documents](#) on page 151

Once your 3D shape is placed in your Adobe Illustrator document, you can see a 3D preview in the Studio window, and see the 2D version in your Adobe Illustrator document.

Applying artwork is as simple as placing the artwork at the correct location in your Adobe Illustrator document.

However, Studio Essentials offers functionality that makes it easier to position and prepare artwork:

- You can select and zoom in on panels or printable parts. See [Working with Parts and Panels](#) on page 121
- You can put 3D guides that are visible in both the Adobe Illustrator file and the 3D preview. See [3D Guides](#) on page 138
- You can apply a conical warp to artwork, to place it on conical labels. See [Conical Warp](#) on page 141
- You can apply predistortion for artwork to be placed on shrink sleeves. See [Artwork Predistortion for Shrink Sleeves](#)

### 4.1. The Studio Window

---

The Studio window is the heart of Studio Essentials in Adobe Illustrator.

It is a floating palette where you can see the three-dimensional shape of the package.

To view the Studio window, choose **Window > Esko > Studio Designer > Show Studio** or use the shortcut **Cmd+Alt+4** (Mac) or **Ctrl+Alt+4** (Windows).



1. The **Maximize** button . Click it to make the Studio window options panel visible. See [The Studio Window options panel](#) on page 115
2. The **Scene**. This can be the Structural Design file used in the current document, or a scene combining multiple documents. See [Scenes and Multiple Documents](#) on page 151
3. The **View** dropdown. You can select a View preset from the dropdown, or click **View** to open the View settings. See [View](#) on page 149
4. The **Orientation**. See [Changing the Document Orientation](#) on page 113
5. The **Fly-out** button, opening the fly-out menu.
6. The **3D preview** of the current document or scene.
7. The **Refresh** button. See [Refreshing](#) on page 112
8. The **Full Screen Preview** button. This will open the Studio Window in full screen preview, until you hit the **esc** key. See [Full Screen Mode](#) on page 114
9. **Show/Hide transparent panels**. See [Working with Parts and Panels](#) on page 121
10. The **Show/Hide Outlines** button adds the outlines of the Structural Design to the 3D preview.
11. The **Show/Hide 3D Guides** button. See [3D Guides](#) on page 138
12. The **Zoom Slider**. See [Changing the view in the 3D preview](#) on page 114

### 4.1.1. Refreshing

By **Refreshing**, the graphics will be (re)drawn on the box. Every time the graphics change, the Studio Window will only update if you click the Refresh button.

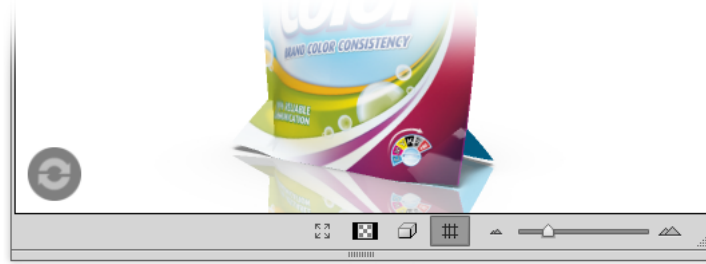

**Note:**

There are different ways to refresh:

- By clicking the **Refresh** button in the bottom left corner of the Studio Window
- By choosing **Window > Esko > Studio Designer > Refresh Studio**
- By using the shortcut **Cmd+Alt+6** (Mac) or **Ctrl+Alt+6**.
- 

### 4.1.2. Designer, Visualizer and Ray Tracing quality

By default, Studio shows a 3D preview in Studio Designer quality. This is the fastest and most basic 3D representation. Since it is the fastest, it is advised to use Designer quality while applying and adjusting the artwork on your 3D shape.

Once you get to the next step, you can switch to a higher quality. See [Step 3: Presenting](#) on page 143

**Visualizer** quality gives a more realistic preview, and shows special effects such as transparency (of e.g. a glass bottle), the reflection on gold foil, etc. It takes more time than **Designer** quality, yet is fast enough to show the result in the Studio window. See [Visualizer Quality](#) on page 143

**Ray Tracing** quality offers photorealistic 3D previews, yet is time consuming to compute. The Studio window will show a low resolution preview, but the full quality of **Ray Tracing** quality can only be seen when exporting an image or image sequence. See [Ray Tracing Quality](#) on page 145

You can switch between the different qualities by selecting **Designer Quality**, **Visualizer Quality** or **Ray Tracing Quality** in the fly-out menu of the Studio palette, or by selecting the quality in the Studio Window settings panel, if no part is selected.

### 4.1.3. Changing the Document Orientation

Use the **Orientation** buttons at the top of the Studio Window to quickly rotate the complete document window. This can make it easier to edit graphics on a panel that is upside down in the file. By clicking the left-most orientation button, the document returns to its original orientation.

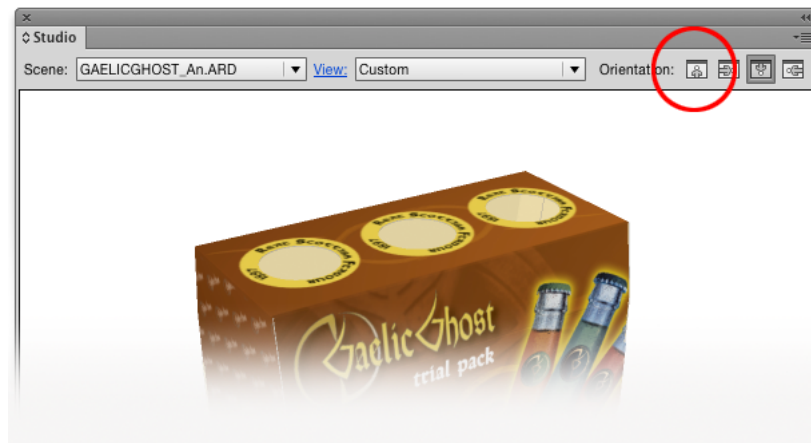

**Note:**

We strongly advise not to save the document while it is still rotated. Before saving the document, you should restore the original orientation. A message will pop up if you forgot to do this.

#### 4.1.4. Changing the view in the 3D preview

In the Studio Window, you can look at the package from different angles.

- You can click and drag to rotate the 3D object.
- You can hold the shift key and click and drag to move the 3D object left, right, up or down (Panning).
- By moving the slider in the bottom-right corner you can look at the box from a closer or further distance. Another way to do this zooming, is by using the mouse wheel.
- You can reset the camera position by double-clicking while holding the shift key.
- When in Visualizer or Ray Tracing Quality, you can click and drag with the right mouse button, or hold the Control key and click and drag to rotate the **Environment**. When in Ray Tracing Quality, you can only rotate the Environment horizontally. Double-click with the right mouse button or double-click while holding the Control key to reset the environment orientation. See also [Environment](#) on page 148

To indicate that the package is not floating in mid-air, the **floor** concept was introduced. A package in the Studio Window is always positioned relative to the floor, giving the package a top and bottom definition. If the package (currently only boxes) is showing the wrong panel as top panel, then you can use the **Turn Box** option. See [Turn Box](#) on page 124



**Note:**

When your box is facing the wrong way and when you have difficulty to turn your box upright, try using Turn Box... The turning around functionality has been designed in such a way that it works fine if you have selected the right bottom panel.

#### 4.1.5. Full Screen Mode

There are different ways to switch your Studio window to full screen mode:

- By clicking the "Full Screen Mode" button  at the bottom of the Studio window
- By choosing **Enable Full Screen Mode** from the Studio Window fly-out menu
- By choosing **Window > Esko > Studio Designer > Enable Full Screen Mode**
- By using the shortcut **F11** on Windows or **Cmd+Alt+-** (minus) on Mac

When full screen mode is activated, you can only change the camera rotation, panning and environment rotation. You can get out of full screen mode by pressing the **esc** key.

### 4.1.6. The Studio Window options panel



By clicking the Maximize button  in the top left corner of the Studio window, you can open the Studio window options panel at the top of the Studio Window.

This panel contains different pages:

- The **No Selection** page, shown if nothing is selected. See [No Selection options panel](#) on page 115
- A page for every **Printable part** in the scene. See [Printable Part options panel](#) on page 116
- A page for every **Non Printable part** in the scene. See [Non Printable Part options panel](#) on page 116

What page is shown, is connected to the current selection. Changing the selection will change the page, and changing the page (using the arrow buttons) will change the selection.

The options panel will always show the amount of parts in the scene.

For more information on navigating and selecting panels or printable parts, see [Selecting Parts and Panels](#) on page 121

#### No Selection options panel

If no part is selected, the Settings panel shows a number of options:

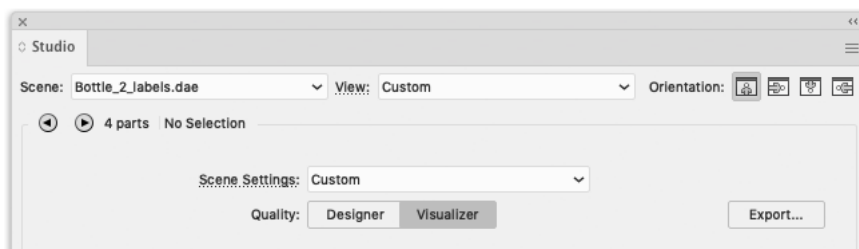

- A dropdown to select predefined **Scene Settings**, and a direct link to open the **Scene Settings** dialog. See [Scene Settings](#) on page 148
- The choice between **Designer** quality, **Visualizer** quality and **Ray Tracing** quality. See [Designer, Visualizer and Ray Tracing quality](#) on page 113
- The **Export** button. See [Step 4: Share](#) on page 175

### Printable Part options panel

If a Printable Part is selected, the settings panel will show the name of the part next to the parts browser.

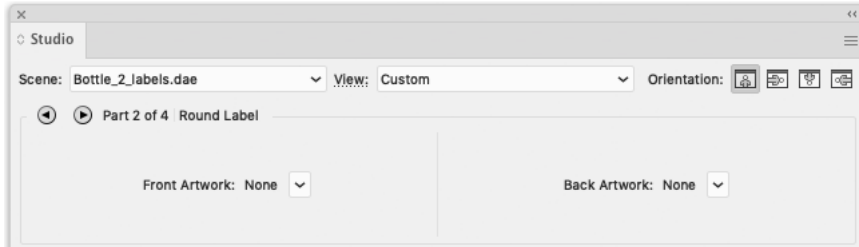

If the printable part has artwork, a link to the corresponding Adobe Illustrator file is shown. Clicking it will give the same result as double-clicking the printable part: the corresponding Adobe Illustrator file will become active and visible.

If the artwork document is missing, "None" appears instead of its name. You can choose to create a new document for this artwork, or place it in the current document. You have the same options when you double-click the printable part in the Studio window.

If the printable part has a back, two links are shown, one for the front and one for the back artwork.

### Non Printable Part options panel

If a Non Printable Part is selected, the settings panel will show the name of the part next to the parts browser.

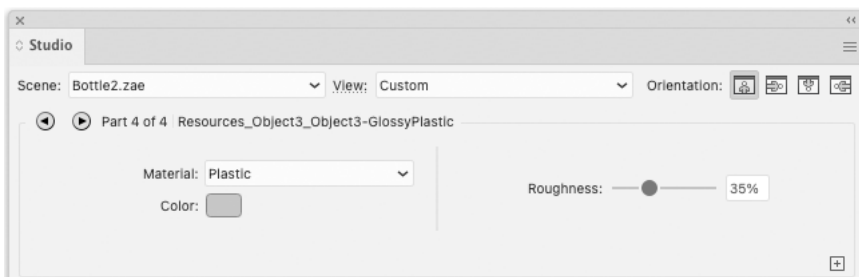

For each of the non printable parts, you can set the material to use for the selected non printable part.

In the dropdown, you can choose:

- Any of the **Materials**, such as glass, plastic, .... See [The Materials](#) on page 117
- **Legacy Plastic**. See [Legacy Plastic](#) on page 118
- **Revert to Structural Design**, to reset the color to the original values of the material as defined in the structural design file
- **Material Presets** to open the Material Presets palette, that contains predefined presets as well as Material Presets you store yourself. See [Working with Material Presets](#) on page 118

By clicking the + button in the bottom right corner of the Non Printable Part option panel, you can store the current material (e.g. Cloudy Plastic) with its parameters (e.g. color, roughness, ...) in the **Material Presets**. This allows you to store and later reuse the combination of a material and its parameters. See [Working with Material Presets](#) on page 118





**Note:** You can't save a preset based on legacy plastic.

## The Materials

The available materials correspond to real materials (plastic, glass, metal, etc...) and their properties. These materials automatically adjust to the capabilities of the chosen quality (Designer, Visualizer, Ray Tracing). For example: Designer won't show transparency.

Clear Plastic, Cloudy Plastic, Glass, Liquid and Cloudy Liquid describe transparent materials and should be used on closed shapes, especially in Ray Tracing quality. (see [Create a profile path for liquids](#) on page 98 for an example)



**Note:** The **Roughness** range of Glass, Clear Plastic and Cloudy Plastic is more limited than for opaque materials such as Plastic and Metal. Due to technical limitations, roughness values outside this limit would result in physically implausible images.

When using Ray Tracing quality, you can set the **At thickness:** With clear plastic, colored glass or liquids, the density of the color changes with the thickness of the material. The **At thickness:** defines the required thickness for the material to reach its color against a white background.

For cloudy liquids, the **color** is an approximation of how a very thick slab of this material would look like.



**Note:** When other geometry intersects with a Cloudy Plastic shape, artifacts (dark spots) might appear within the Cloudy Plastic.

## Textures

If the **Material** is set to **Plastic**, you can assign a **texture** to the plastic.

1. Click the **Color** patch
2. Select the **Texture** tab
3. Click **Choose Texture** and select the texture file to use.
4. Click **OK**

The repetition of the texture is based on its physical size.

You can switch back to a solid color by selecting the **Solid Color** tab.



**Note:**

To render textures correctly, an object needs **texture coordinates**.

- For revolved objects texture coordinates are generated when they are revolved in Toolkit 23.03 or higher.
- Revolved objects created in older Toolkit versions can be resaved to get texture coordinates.
- Revolved objects made in the Studio Toolkit for Labels plugin for Illustrator do not have texture coordinates.
- Other third party objects can have texture coordinates if the 3D artist provides them.

### Legacy Plastic

The Legacy Plastic material is built around the capabilities of Visualizer quality. For Ray Tracing quality this material is insufficient and will fall back on an opaque plastic appearance. Use this material type if you do not plan to render your scene in Ray Tracing quality and if you want full control over all rendering parameters.

Otherwise we recommend that you use the other materials. They are easier to configure and can be used across Designer, Visualizer and Ray Tracing quality.

For Legacy Plastic, you can set the following properties:

1. the **Color** (the diffuse component);
2. the **Transparency** (the alpha channel of the diffuse component, only available in Visualizer quality),
3. the **Highlight Color** (the specular/reflection component, only available in Visualizer quality),
4. the **Intensity** of the reflection (the value of the specular component, only available in Designer and Visualizer quality)
5. the **Sharpness of reflection** (shininess)

### Working with Material Presets

Using the **Material Presets**, you can store and reuse the combination of a material (e.g. Cloudy Plastic) and its parameters (e.g. Color, Roughness, ...) used for non-printable parts.

After installing Studio and launching Adobe Illustrator, the Material Presets will contain a list of predefined presets. These can be handled as regular presets, and give an example on how material parameters can be used to get a specific appearance.

- You can open the **Material Presets** dialog by choosing **Window > Esko > Studio Designer > Show Material Presets** or by using its shortcut **Cmd+Alt+=** (Mac) or **Ctrl+Alt+=** (Windows)



**Note:** In the **Fly-out** menu, you can set the view mode: choose between **Small List View**, **Large List View** or **Grid View**

- Add a Material Preset by clicking the + button in the Non-Printable Part panel in the **Studio window**. The Material Preset will use the current settings of the Non-Printable Part. See [Non Printable Part options panel](#) on page 116
- Apply a Material Preset to the currently selected Non-Printable Part by clicking the Material Preset in the list
- Rename a Material Preset by double-clicking it in the list
- Remove a Material Preset by selecting it and clicking the **Delete** button or choosing **Delete Material Preset** from the fly-out menu.



**Note:** If you rename or delete a predefined preset, it will not be reinstalled automatically. You can however edit the "PresetsConfig.txt" file. See below.

The Material Presets are stored as separate files that can be found here:

- On Macintosh: Macintosh/Users/user/Library/Application Support/Esko/Studio/Material Presets/
- On Windows: C:\Users\user\AppData\Roaming\Esko\Studio\Material Presets\



**Tip:** You can easily reach that folder by selecting **Show in Finder** (Mac) or **Show in Explorer** (Windows) in the fly-out menu of the Material Presets palette

You can exchange the Presets between different operators by copying the files to another computer.

The Material Presets palette represents the content of the Preset location. This means that you can use Finder / Explorer to rename, duplicate or remove Presets.

By creating subfolders, you can create groups in the **Material Presets** list.

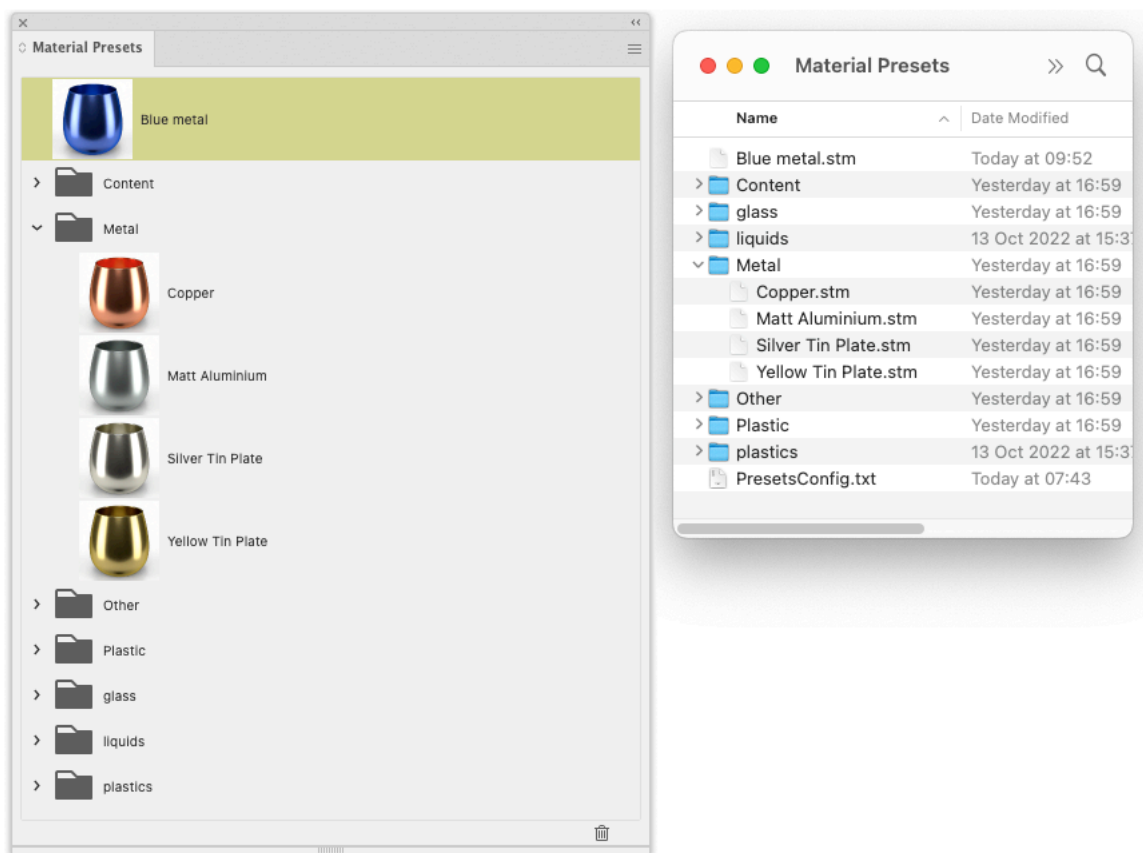

The **PresetsConfig.txt** file contains a list of all predefined presets that were already installed. This means that if you remove an entry from the list, it will be reinstalled when relaunching Adobe Illustrator. This can be used to reinstall predefined presets that were deleted or renamed.



**Note:**

**Editing** a Material Preset is not supported. What you can do is:

1. Apply the Preset to a Non-Printable Part
2. Change its parameters
3. Save it as a new Preset.

### Send Non-Printable Materials to Toolkit

Using **Send Non-Printable Materials to Toolkit** you can store the material settings you defined in Adobe Illustrator into the structural design file.

1. Set the non-printable materials in the Non Printable Part options panel. See [Non Printable Part options panel](#) on page 116
2. In the fly-out menu of the Studio window, choose **Send Non-Printable Materials to Toolkit**



**Note:** When the non-printable parts have the same material assigned as defined in the structural design file, the option will be disabled.

The structural design file will be opened in Studio Toolkit, and the new materials are shown for the object.

3. In Studio Toolkit, save the structural design as a Collada File.

This new Collada file will contain the new materials. When this file is placed in Adobe Illustrator or imported in Studio Toolkit, it will have the new materials assigned.

## 4.2. Working with Parts and Panels

---

A box design and a bag design consist of a set of **panels** which are folded relative to each other.

Some of the Studio Toolkits can produce Collada files with more than one **Printable Part**.

While **panels** of the same side are in one single Adobe Illustrator file, you can have a separate file for the Front and the Back side. Also, every **Printable Part** will have its own Adobe Illustrator document. For more information on working with multiple documents, see [Scenes and Multiple Documents](#) on page 151

### 4.2.1. Selecting Parts and Panels

You can select parts and panels by clicking on them in the Studio window. The selected panel is used by certain Studio Designer features and does not affect the selected artwork.

- A Printable part or panel will be selected in red. When selecting a non printable part, all non printable parts sharing the same material will be highlighted in orange. For multiple instances (e.g. multiple cans on a tray), only the printable parts of the original instance will be highlighted.
- If the selected part or panel is in your current Adobe Illustrator document, **Show Face Outline** (in the fly-out menu) ensures that the selected panel is also shown in your document as a blue solid line.
- By holding the option (Mac) or alt (Windows) key and clicking a panel or part one or several times, you can select a panel or part that is behind another one.

See also:

- [Zooming in on Panels in the document window](#) on page 123
- [About Hidden Panels](#) on page 123
- [Scenes and Multiple Documents](#) on page 151

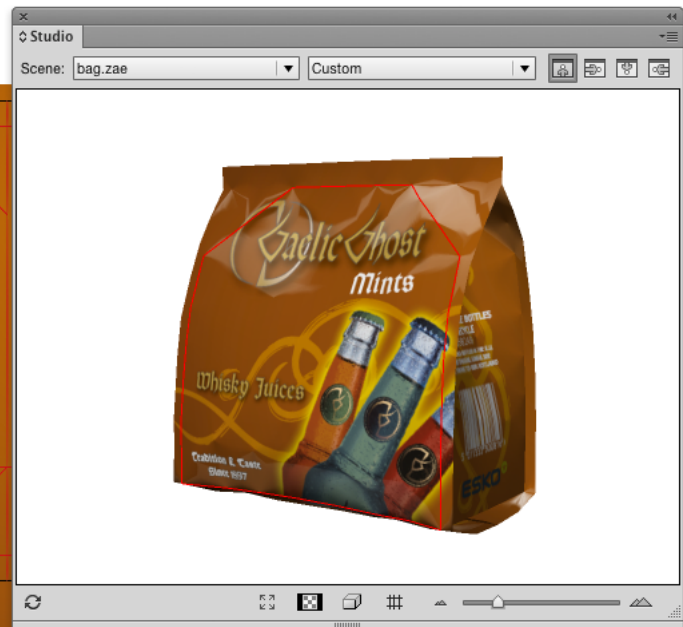
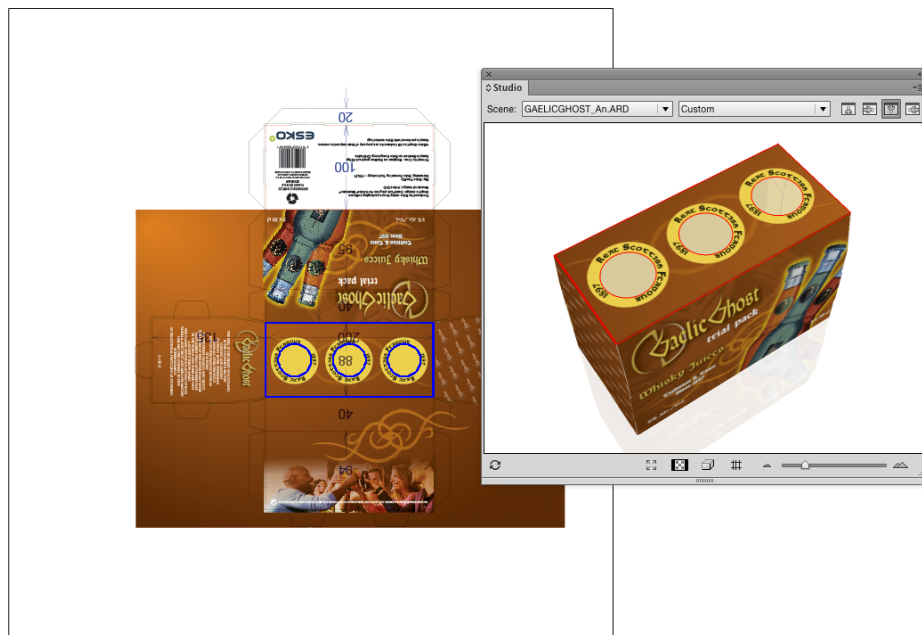



**Note:**

Sometimes a dotted line appears next to the solid one. This is the case when you select a panel that is also part of a **composed face**.

### 4.2.2. About Hidden Panels

Some panels cannot be seen in the Studio Window because they are covered by another panel no matter which angle you are viewing the package from. To see those panels, you can choose **Show Transparent Panels**, which is available at the bottom and from the Studio Window fly-out menu. In this mode the package is drawn in a semi transparent way, allowing you to see covered panels. This will help you to understand how the package's 2D unfolded view and the 3D view relate to each other.



By holding the option (Mac) or alt (Windows) key and clicking a panel one or several times, you can select a panel that is behind another panel.

### 4.2.3. Zooming in on Panels in the document window

If you double-click a panel (or if you select **Fit Panel in Document Window** from the Studio Window's fly-out menu), the document window will zoom in on the corresponding part of the graphics.

If your graphics are in another document, then this document will become active. See [Scenes and Multiple Documents](#) on page 151

Furthermore, the orientation of the document window will change to match the orientation in the Studio Window as closely as possible.

You can also zoom in by holding down the Cmd (Mac) or Ctrl (Windows) key and dragging a rectangle around the area you want to zoom in on.

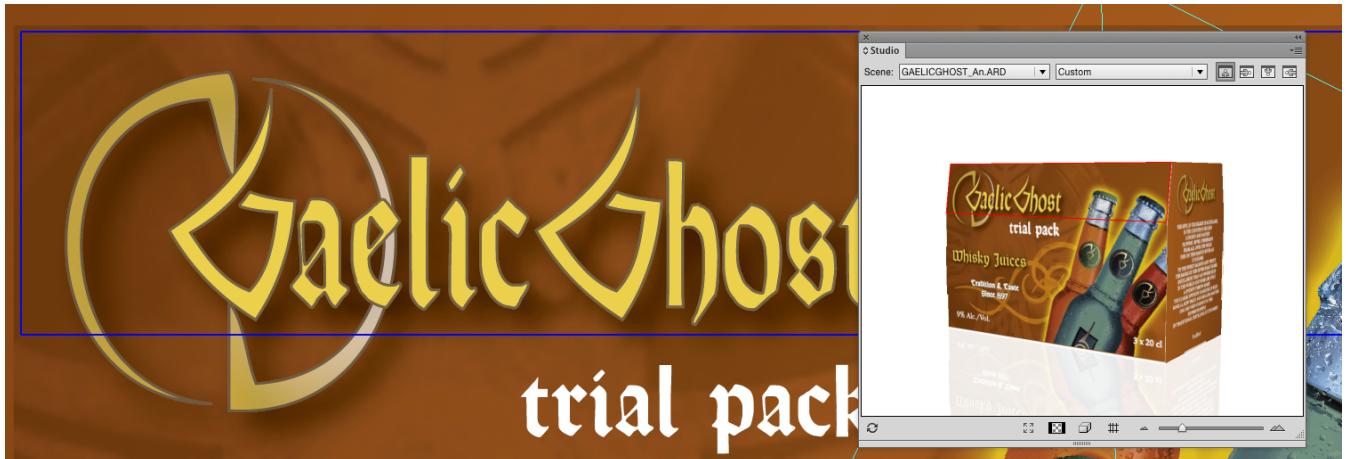

By spinning the package and double-clicking the different panels, the Studio Window can be used to navigate through the document.

#### 4.2.4. Turn Box

When working with designs for folding carton or corrugated boxes, you might not be able to position the box in the desired viewing angle in the Studio Window. This happens when the package has the wrong panel(s) facing up. You can change this e.g. in the structural design file (by selecting another Base Panel in ArtiosCAD), but you can also turn the box in the Studio Window. Just select a panel that should be facing up or down and select **Turn Box** from the Studio fly-out menu. The Turn Box functionality is linked with the Floor concept, so e.g. **The selected panel facing up** means that the selected panel will become the top panel relative to the floor.



**Note:**

The Turn Box option is only available for boxes (ARD files)



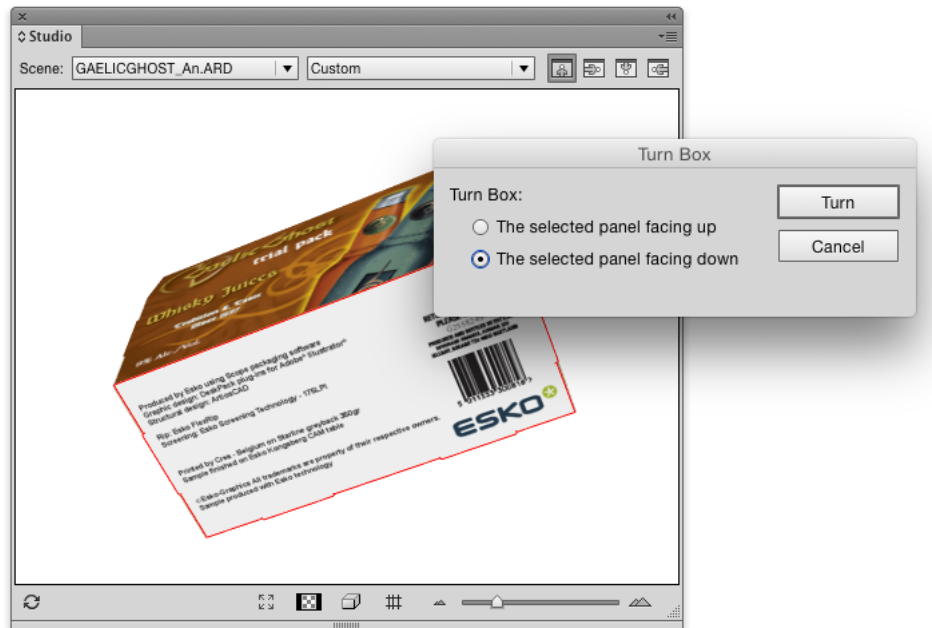

#### 4.2.5. Bring Panel Forward and Send Panel Backward

This functionality is only available for ARD and ACD shapes. It can only be used on boxes and composed faces of which the panels are all in the same plane. Overlapping panels in the same plane can occur in any file. Sometimes the order of these overlapping panels is incorrect. Most of the time, this will happen when the panels have been folded 90 degrees on top of each other. With **Bring Panel Forward** and **Send Panel Backward**, you can correct this order.

If you wish to view another panel on top, you can select the panel, select **Bring Panel Forward** from the Studio fly-out window and bring it forward.



**Note:**

When opening an Illustrator file saved in an earlier version of Studio Designer (without "Board Thickness"), the Bring Panel Forward and Send Panel Backward information from this file will be lost.

#### 4.2.6. Creating Copies with the Distribute command

Most of the faces of a package consist of a single panel. So there is just one rectangular area in the document that will make up this face. However, sometimes a face is made of several panels. The panels of such a "composed face" are spread across the document. They can even have a different orientation. So for composed faces it is very difficult to create graphics that run continuous from one panel into the other. Studio Designer can help you in this process with a feature called **Distribute**.



**Note:**

You can use Distribute on .bag, .ard and .acd files but not on Collada files.

### Composed Faces

This is an example of a box with composed faces.-



This is an example of a bag.

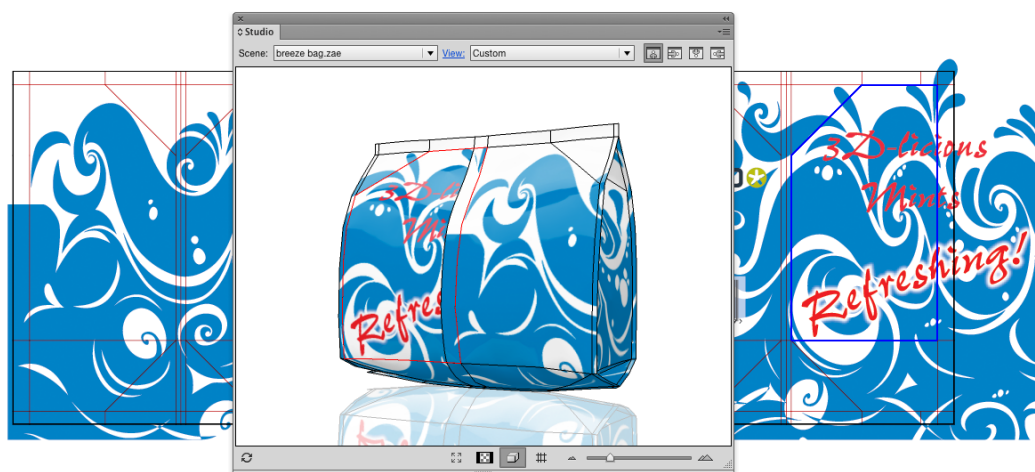

### Viewing the Composed Face

If you select **Show Face Outlines** in the Studio fly-out menu and you click one panel that is part of a composed face, 'ghost' outlines will be drawn of the other panels of that face. These ghost outlines can give you a good impression of the size and shape of the composed face.



### Distribute

If you draw some art within the boundaries of such a composed face, it will only appear on one panel, since the other panels are actually somewhere else in the Illustrator document. However, with **Distribute**, you can create copies of the art over several panels that are perfectly aligned to make it look continuous on the folded composed face.

This is how the folded package will look without applying Distribute.

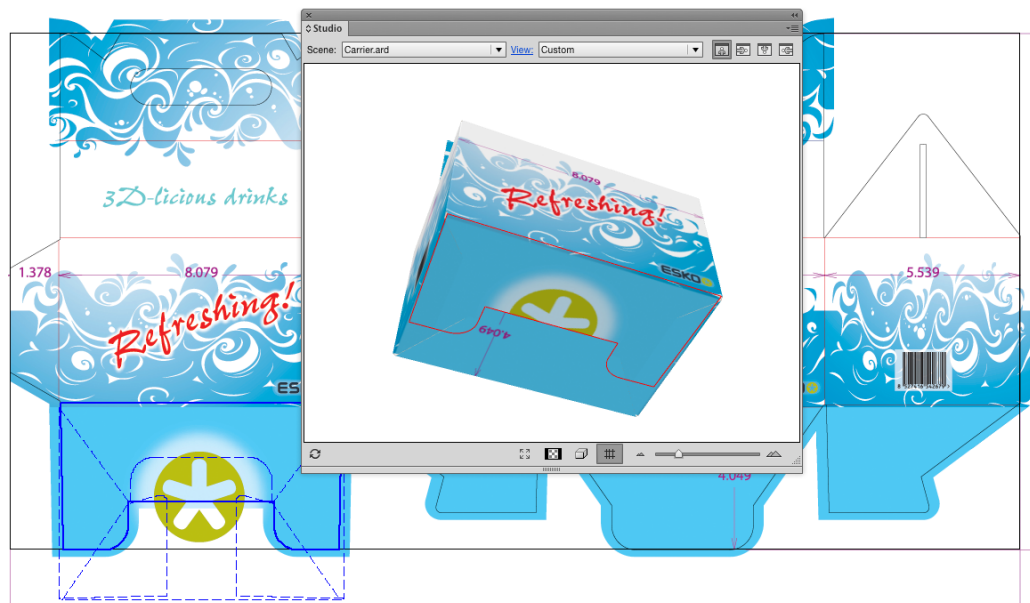

**Distribute** is available from Studio's fly-out menu. First you need to select art in the document and you need to select the corresponding panel in the Studio Window. The selected art is supposed to be positioned correctly on the selected panel. If you choose **Distribute**, copies will be made of the

selected art for the other panels (of the same composed face). After refreshing the Studio Window you can see how the graphics are running seamless from one panel into another.

Normally, distribute will make a copy of the selected objects for every panel in the composed face (unless there is no overlap). If you do not need all these copies, you can simply delete the ones you do not need.

This is how the folded package will look when having applied Distribute.



### Making Clipping Masks

It is very likely that one or more of the copies lay partially outside of the panel they were created for. Sometimes this is a desired effect (having the graphics run continuously over a folding line). Sometimes this is not a desired effect and you will have to create a clipping mask to contain the copy within its panel.

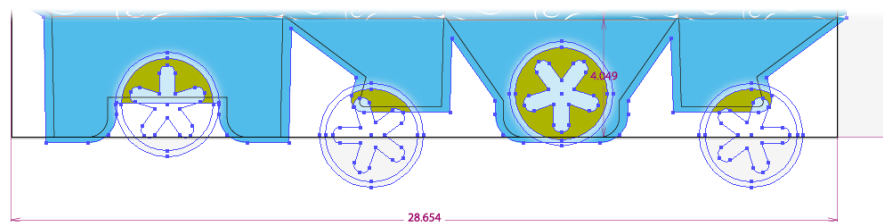

### Working With Distributed Art

You can update the copied distributed art, for example after you have edited the original art; or you can undistribute and expand distributed art if you want to delete the copies.

### Update Copies

After a 'distribute', you will have the same art appearing several times in your document. If you change one of them, the others will not be updated automatically. To have them updated, select **Update Copies** from Studio's fly-out menu. When updating copies, the selected one is used to recreate all the other copies.

This is how the package looks before updating.



This is how the package will look after updating.



### Undistribute and Expand

The options **Undistribute** and **Expand**, which can be found in Studio's fly-out menu also apply to distributed art. If you select distributed art and you **Undistribute**, all other (non-selected) copies are deleted. If you have distributed art selected and you **Expand**, nothing will change visually yet the selected art will lose its 'intelligence' and become regular artwork, insensitive to actions like **Update Copies** or **Undistribute**.

You will need to use **Expand** if you start copying and pasting distributed art. The copy will still be considered as part of a distribution, by expanding it, it will no longer be seen as a distribution, but as an ordinary object.



**Note:**

When the distributed art is a group, ungrouping it is equivalent to applying **Expand**. The art does not longer know that it was distributed, even if you group it again.

### There is no overlap between the selected objects and the selected panel

I try to distribute a logo, and I am getting the error message There is no overlap between the selected objects and the selected panel. Please select a panel that overlaps with the selected objects.

Whenever distributing for the first time, you will need to select two things: the graphics that you want to distribute in the 2D view AND the source panel in the Studio window. The 'no overlap' error message indicates that you did select a panel in the Studio window, but in 2D there is no overlap between the selected panel and the selected art.

It is a good idea to switch on **Show Face Outlines** in Studio's fly-out menu.

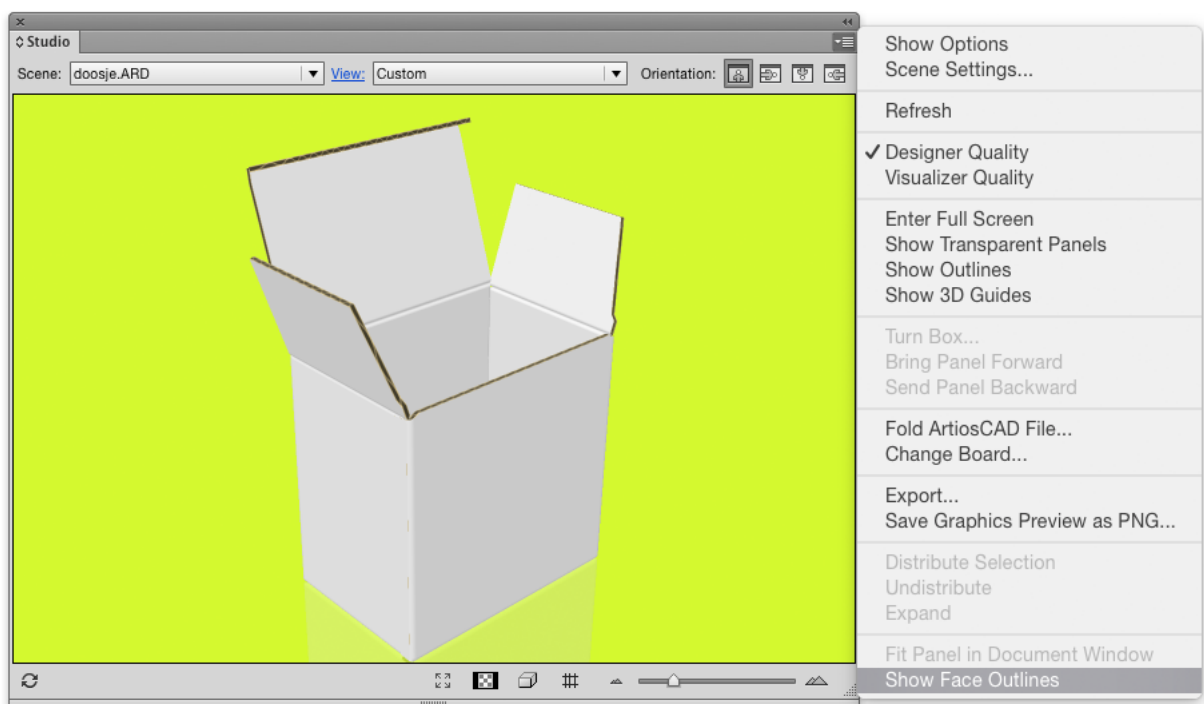

When **Show Face Outlines** is switched on, the selected panel in the Studio window will be shown in the 2D View:

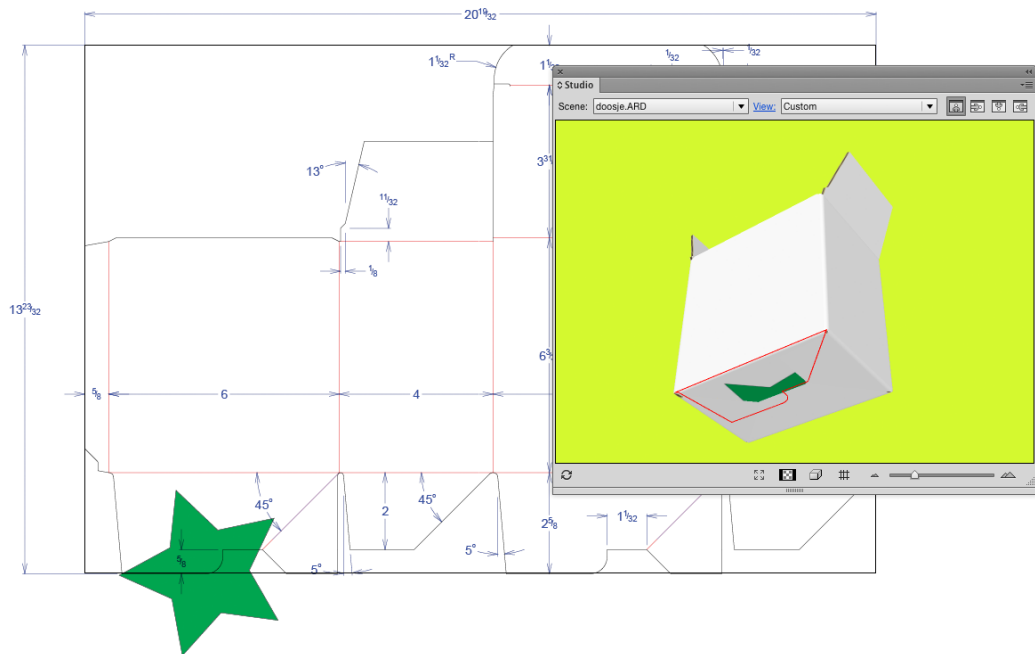

You will immediately see that there is no overlap between the selected panel (the blue rectangle) and the selected art (the star), so you basically selected the wrong panel. You need to select a panel that has an overlap with the selected art:

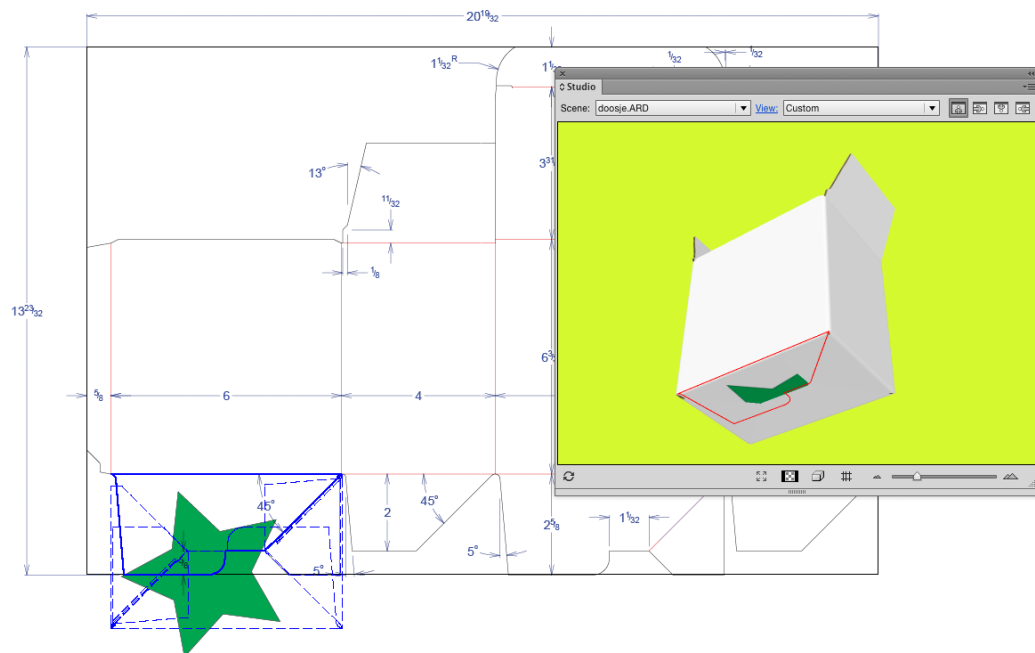



Now you see that there definitely is an overlap between the blue rectangle and the star. You will notice that **Distribute Selection** will work, which will give you the following result:

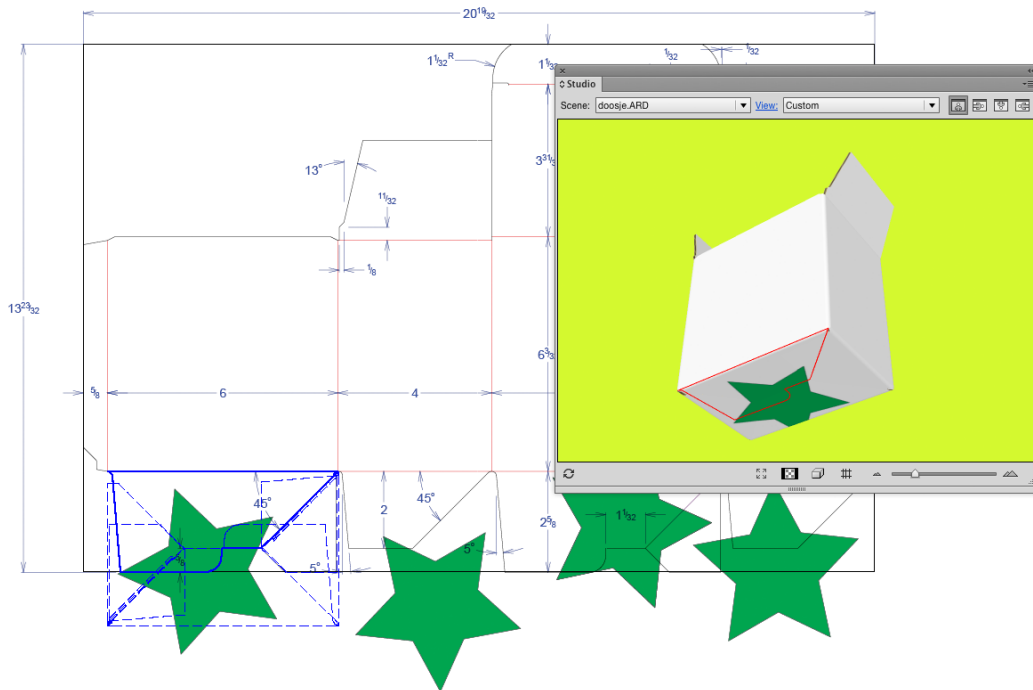

Please note that you never had to specify to which ‘target panel’ you had to distribute, so how can you know which target panels will be taken?

In this version of Studio Designer, the distribute functionality only works on coplanar panels. The bottom face consists of four panels coming together: two glue panels and two larger panels. The selected panel is drawn with a solid blue line in the 2D View, the other panels that are coplanar with it are drawn with dashed lines. Distribution happens from the panel drawn with a solid blue line to the panels drawn in dashed blue lines.

That is why **Show Face Outlines** is so interesting, as it immediately gives you an indication whether or not distributing is at all possible and to which panels the distribution will happen.

If we move one of the stars and do an update, you will notice that the three other stars need to move as well. It is now enough to select the moved star and click **Update Copies**. You will notice that **Distribute Selection** is now called **Update Copies**. There is no need anymore to select a panel in the Studio window.

The selected art knows that it has been distributed before. This piece of distributed art has become a smart object that knows to which panel it belongs and which other art belongs to the same distribution. When clicking **Update Copies**, the other art that belongs to the same distribution (in our example, the other stars) will be replaced with a new updated copy of the selected distributed art.

In the layer browser, you have an indication which art is “distributed art” and hence smart. The name of distributed art is always “Distribution”.



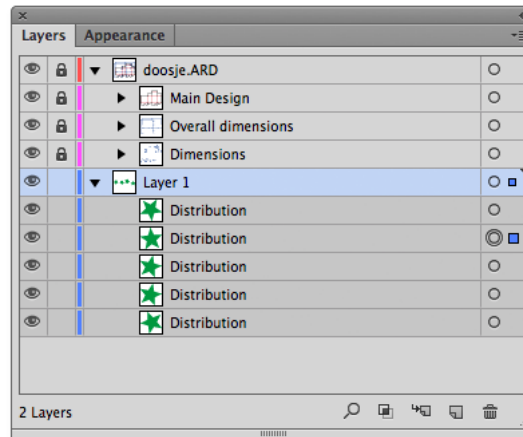

### What can I do if the distribution looks wrong?

The graphics have been distributed to the correct coplanar panels, but the result of the distribution in the Studio window is still not correct.

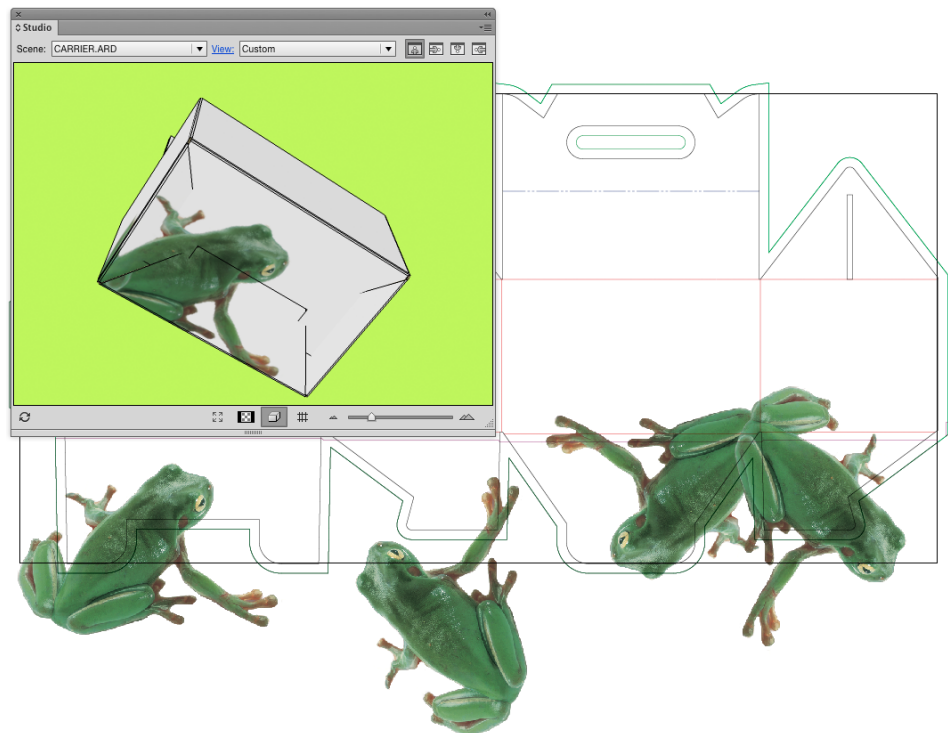

In this case it is not that the distribution has positioned the copies in the wrong place, but that in the 2D document window, the different copies are overlapping one another. This can happen whenever the graphic that you want to distribute is rather large. We will need to make clipping masks in this case, using the standard tools.

In the picture below, we are zooming in on one of the distributed copies, made a clipping mask with the appropriate tool, selected both the graphics and the clipping mask and clicked **Clipping MaskMake**.

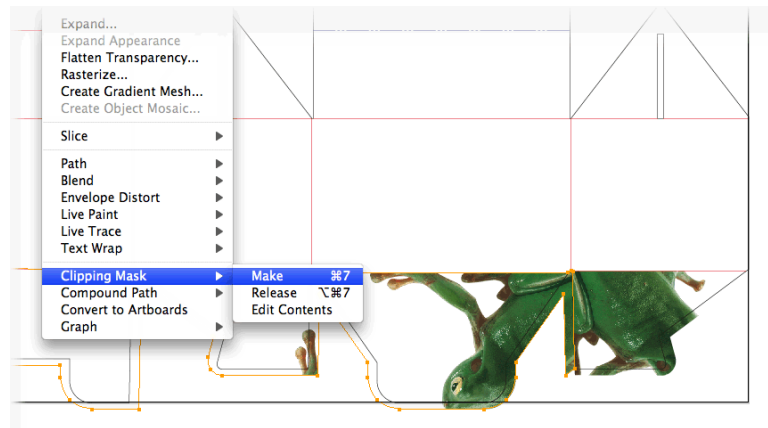

If we do this for every distributed copies and then refresh the Studio window, we will get the correct result:

You only need to make the clipping masks once. Assume you would like to move the frog a little, then simply move one copy and click **Update Copies**. The other copies will also be updated and they will keep their position under their clipping masks.



**Note:**

When using ard files there is an easy way to create a clipping path to clip objects on the e.g. Bleed Outline. Use **Expand Structural Design Layer** functionality to e.g. expand the bleed outline to use that path as a clipping path. See the Esko Data Exchange documentation for more information.

**How can I distribute around a corner?**

Distributing is only possible to other coplanar panels. Sometimes a distribution appears to go around the corner, but this only works if a panel that is attached to the panel around the corner is coplanar with the selected panel.

This is not the case with the box in the next example.

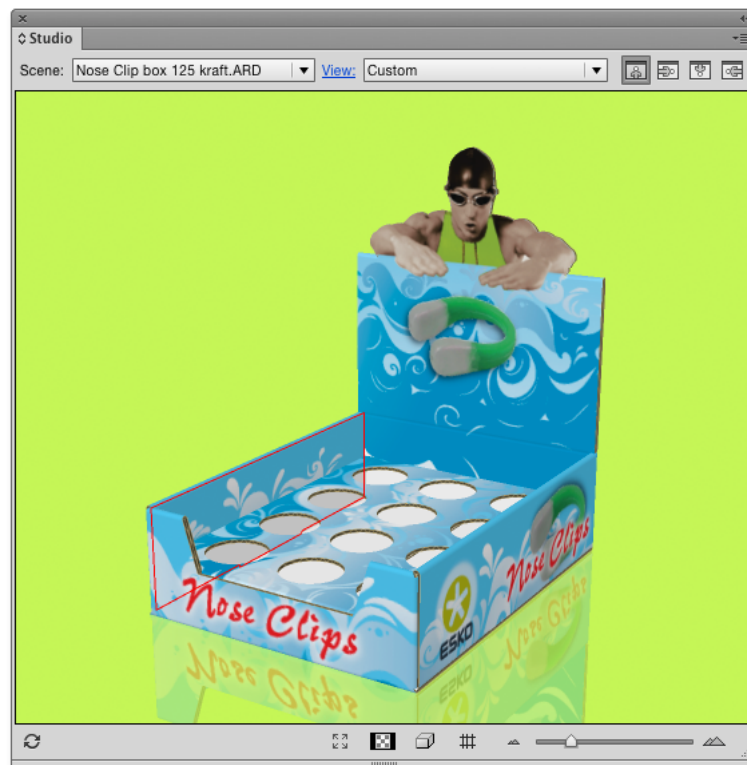
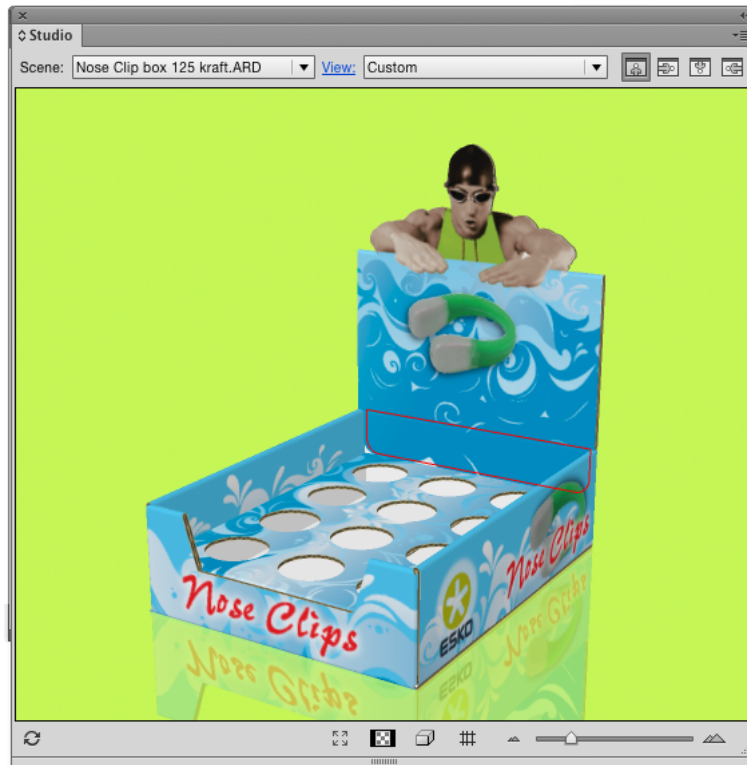

In this version of the software, we are not capable of doing this with the automatic distribute. We have limited the distribution functionality to panels that are coplanar. A face in the Studio window can be made up of different panels coming together. A beautiful example is the bottom of the box in the picture below.

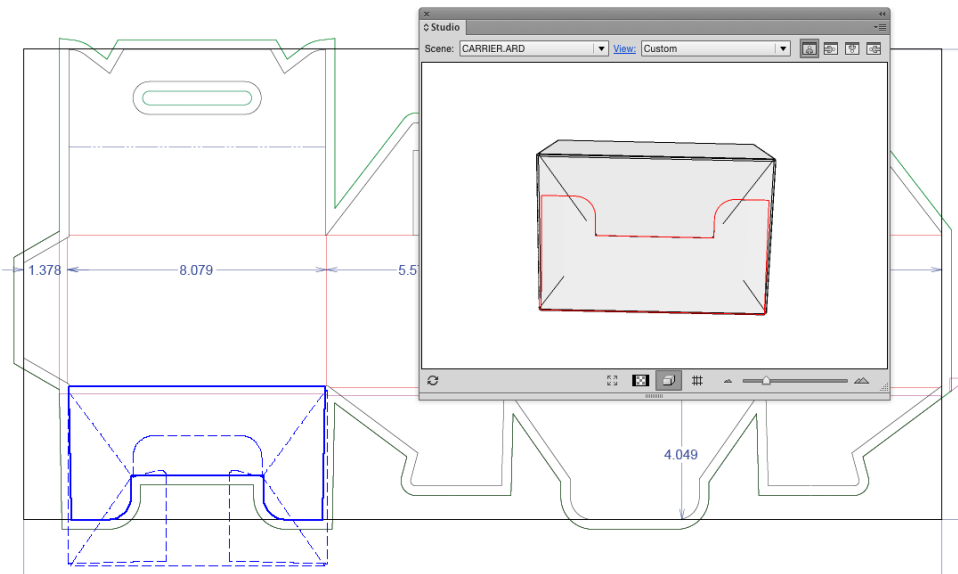

The bottom of this box consists of four panels coming together. If you select **Show Face Outlines** in the Studio's fly-out menu, you will see blue lines showing up in your 2D Document Window. The solid blue line is a reflection of the selected red panel in the Studio Window. The other panels that are coplanar with the selected panel and that together form the bottom face, are drawn on top of that in dashed lines. If you were to draw some graphics and click **Distribute Selection** then the graphics would be copied and pasted to the three other panels that are coplanar with the selected one. Those three panels are shown with dashed blue lines in the 2D Document Window.

In the following example, we would like a distribute from one panel to another that is adjacent to the first in the Studio Window, but they are not at all coplanar. On the contrary, the angle between the two panels is 90 degrees. As automatically distributing will be impossible in this case we will have to do the copying, rotating and pasting of the graphics ourselves. The **Create 3D Guide** option can be a solution.

You could create a 3D Guide in the back inner panel and that is immediately going to create extra guides in the other panels that the guide plane intersects with.

You could now design your graphics in the back inner panel. You do not need to do this upside down as double-clicking on the panel in the Studio Window will rotate the whole job. You can also rotate your job manually using the orientation buttons in the right top of the Studio Window.

We will add some text to this panel that also needs to extend into the other panel.



We will now copy the text, double-click the other panel in the Studio Window where you would like the text to be pasted, paste the text, rotate it and position it correctly on the guide:

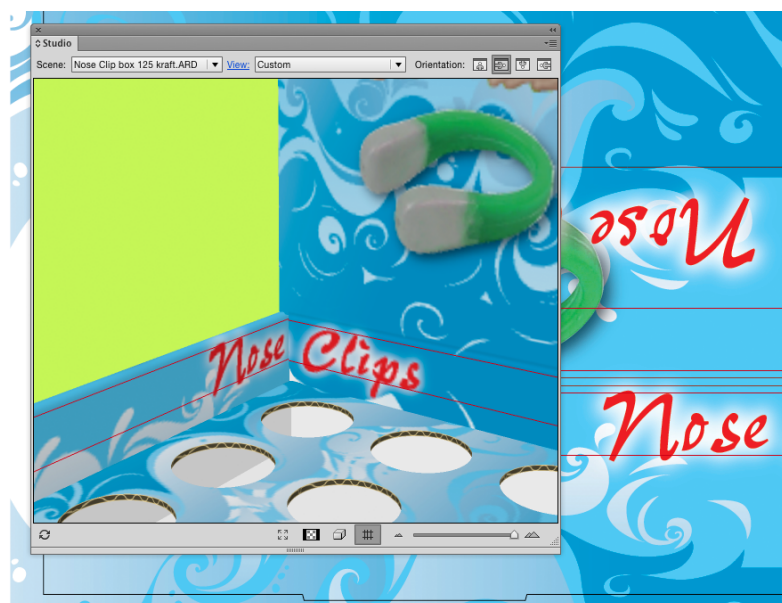

Of course you will still need to refresh the Studio Window more than once, before you will have found the exact position of the text on the second panel.

### 4.3. 3D Guides

In Illustrator, PackEdge, ... you can create horizontal and vertical Guides to align art. Studio Designer offers another type of guides: 3D Guides for boxes and Collada files.

3D guides appear both in the document window and in the Studio Window.



**Note:** 3D guides are temporary visual aids, and are NOT saved.

You can hide or show the 3D guides in the document window using the application's View settings, by selecting **View > Guides > Show Guides**.

Select **Show/Hide 3D Guides** from the Studio fly-out menu or click the button at the bottom  to hide or show the 3D guides in the Studio Window.

If you are looking at a multi-part shape in the Studio window, the 3D guides will intersect the different parts, and result in guides in multiple documents.

In the Studio Window, the 3D guides appear like a horizontal or vertical plane that is intersecting the shape. In the document, a 3D Guide appears like a set of horizontal, vertical or even slanted line segments clipped inside panel boundaries. These line segments show where the plane is intersecting with the panels. Graphics can snap to these segments just as with regular guides.

This is how the 3D guides are presented in the 2D and 3D view:

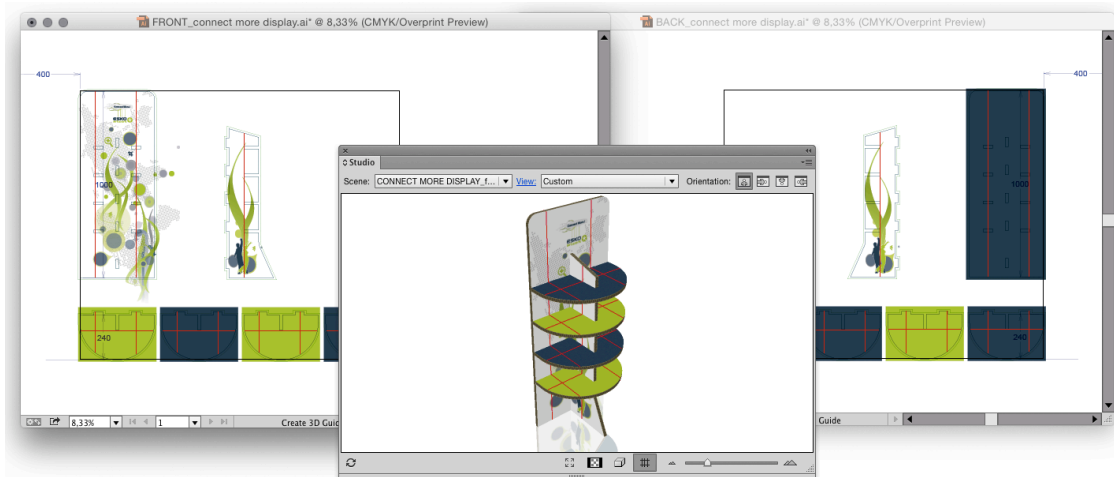

For Collada files made with Studio Toolkit For Labels, you can get curved 3D Guides in the document if your printable part is a conical label:

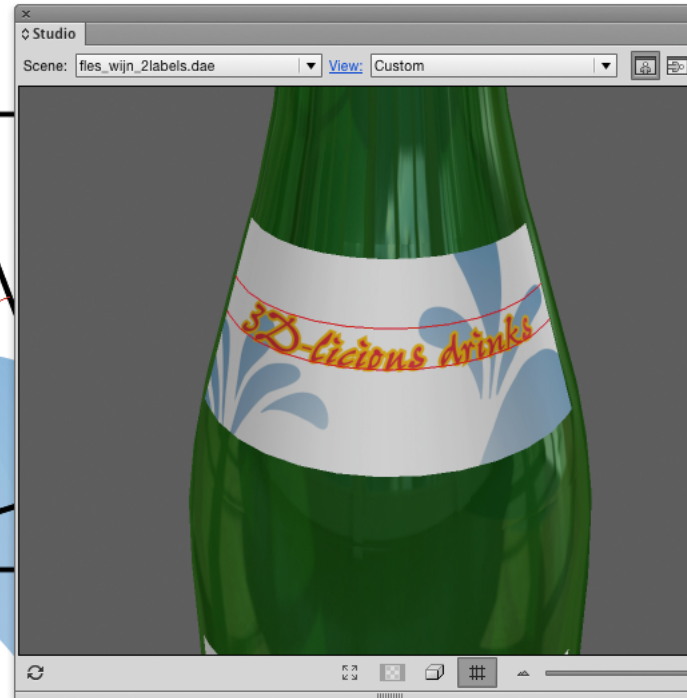

### 4.3.1. Creating and Editing 3D Guides

To create or move a 3D guide, use the **3D Guide** tool (in the applications toolbar). Click and drag somewhere in the shape in the document to create or move a guide. By holding the option (alt) key, you can switch between vertical and horizontal guides.



**Tip:**

If you are using Adobe Illustrator CC 2019, your Esko tools might not be visible in the toolbar. There are two ways to make your tools visible:

- Switch to the Advanced toolbar by selecting **Window > Toolbars > Advanced**
- Locate the tool you want (when invisible, you can find it by clicking "..." in the toolbar) and drag it to the desired location in the toolbar. For more information on customizing the toolbar, we refer to the Adobe Illustrator documentation.

To delete a 3D guide, use the 3D guide tool and simply drag it outside the shape in the Illustrator document.

To delete all 3D guides, you can delete the "3D Guides" layer that contains all 3D guides or use **View > Guides > Clear Guides**.



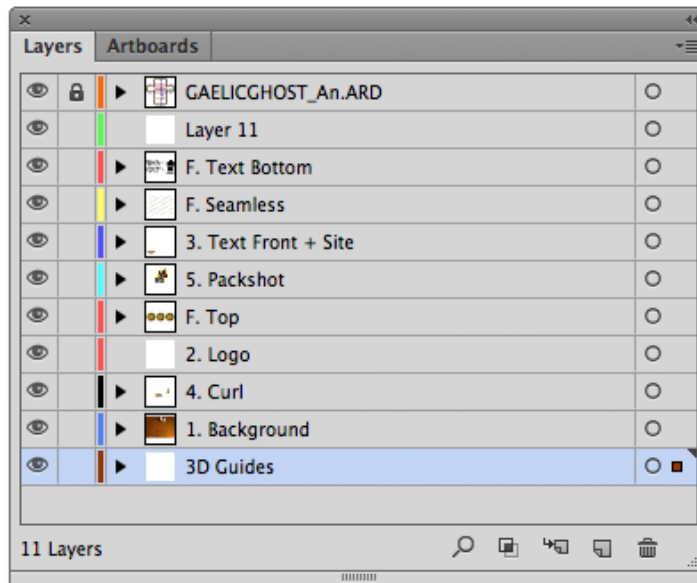

### 4.3.2. Numeric Positioning of 3D Guides

Double-click the **3D Guides** tool to show the **3D Guide** floating palette. You can use this to move or copy 3D guides numerically.

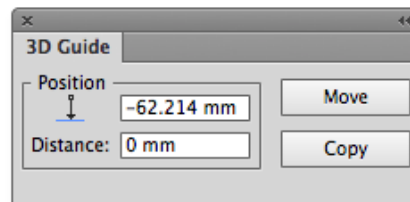

## 4.4. Conical Warp

Studio Essentials contains functionality to warp artwork based on conic labels you created in Adobe Illustrator based on a revolved shape. See [Creating a revolved shape with labels](#) on page 95.

This functionality contains:

- The **Conical Warp** function in **Window > Esko > Studio Toolkit for Labels** . See [To apply conical warping](#) on page 142
- The **Release Warp** function in **Window > Esko > Studio Toolkit for Labels** . See [To reverse the conical warping](#) on page 142



**Note:** For labels created in Studio Toolkit, you can't use Conical Warp. If you have a Studio Toolkit for Shrink Sleeves license, you can however use **Predistort**.

### 4.4.1. To apply conical warping

Using Studio Essentials, you can modify artwork to match the shape of a conic label.

Obviously, this can only be done after creating a shape and adding labels in the **Revolve and Add Labels** dialog. See [Creating a revolved shape with labels](#) on page 95

1. Select the objects you want to modify. Make sure this artwork overlaps with a conical printable part.
2. Select **Window > Esko > Studio Toolkit for Labels > Conical Warp**

This will instantly apply a warp on the selected objects. The warp is calculated around the center of the bounding box of the selected objects.

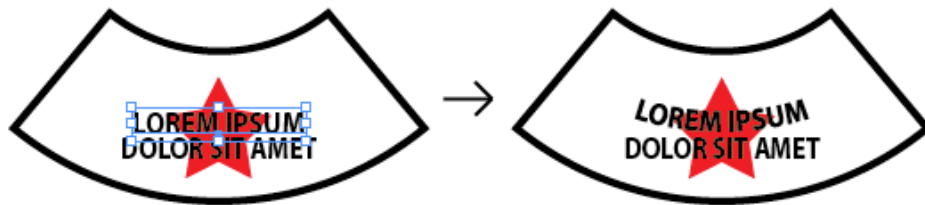

**Note:**

The warping is non-destructive, so you can still easily remove the distortion envelope, and text is still editable.



**Note:**

To apply the warping, Studio Toolkit for Labels creates Illustrator Envelope Distort objects. Adobe Illustrator has some limitation on Envelope Distort objects: you can not distort linked images. For this, you need to embed the images first.

### 4.4.2. To reverse the conical warping

1. Select objects that were warped using the **Conical Warp** function
2. Select **Window > Esko > Studio Toolkit for Labels > Release Warp**

The warping of these objects is reversed, restoring them in their original state.

## 5. Step 3: Presenting

### 5.1. Visualizer Quality

By default, Studio shows a preview in Studio Designer quality. You can switch to the enhanced Visualizer Quality preview, by selecting **Visualizer Quality** in the fly-out menu of the Studio palette, or by selecting **Visualizer** in the Studio Window settings panel, if no part is selected.

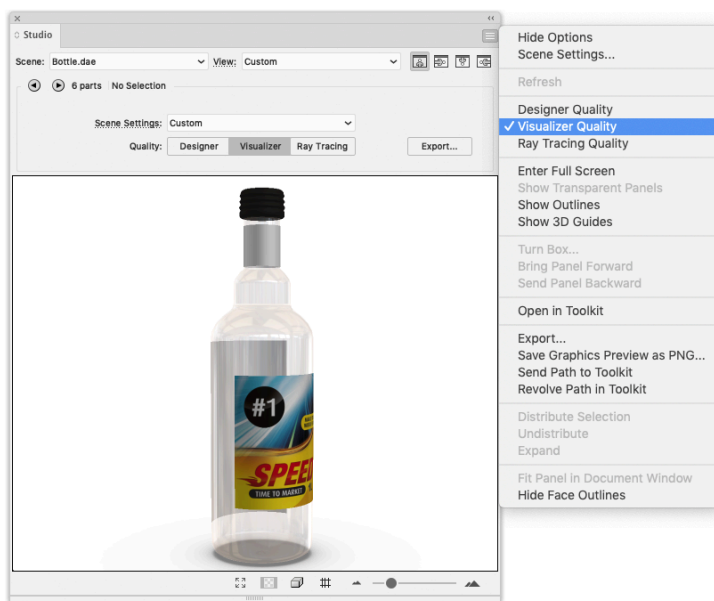

When switching to **Visualizer Quality** the artwork in the Studio Designer window has to be regenerated. Depending on the job and the resolution chosen this can take some time.



**Note:**

**Visualizer Quality** uses a different background color than Designer Quality. Not only the default background color is different (gray instead of white), but changing the background color while in Visualizer Quality will not change the background color used for Designer Quality and vice versa. Changing the background images applies to both Designer and Visualizer Quality.

You can change the background color or select a background image from the **Scene Settings** dialog, which you can open by selecting **Scene Settings** from the fly-out menu of the Studio palette. See [Scene Settings](#) on page 148



**Note:** When in Visualizer Quality or Ray Tracing Quality, certain (technical) inks will be ignored by the 3D Print Modeling. They will not be visible in the Finishing Operations palette, and will not be visible in the 3D preview or Export. See [Inks ignored in the 3D view](#) on page 144

### 5.1.1. Refreshing

If you make changes to the artwork or to the Finishing Operations, these changes will only be visible in the Studio palette after you click the **Refresh** button. See also [Refreshing](#) on page 112

Since calculating the Visualizer Quality preview can be more time consuming, we advise to only switch to Visualizer Quality when the operations that simulate the printing processes are applied and ready. When you are still busy creating and adapting the artwork, using Designer Quality will update the 3D model much faster.

As long as your 3D design is up to date, **Refresh** is not available.



**Note:**

Refresh is also available via **Refresh Studio** in the **Studio Designer** menu, using **Refresh** from the fly-out menu of the Studio palette, or via the default shortcut **Cmd+Alt+6** (Mac) or **Ctrl+Alt+6** (Windows)

### 5.1.2. Inks ignored in the 3D view

When in Visualizer Quality or Ray Tracing Quality, certain (technical) inks will be ignored by the 3D Print Modeling. They will not be visible in the Finishing Operations palette, and will not be visible in the 3D preview or Export.

When working in **Normalized PDF Mode**, all technical inks will be ignored.

When working in **PDF+ Mode**, inks used in Processing Steps (so-called "colorants") will be ignored, except for inks used only in one of the following Processing Steps:

- Structural: Emboss, Deboss, Cold Foil Stamping or Foil Stamping
- White
- Varnish
- Braille



**Note:** When an ink is used in one of above mentioned Processing Steps along with one or more "Legend" Processing Steps, the ink will not be ignored.

For more information on Normalized PDF vs PDF+ Mode, we refer to the **Ink Manager** chapter in the [Esko Data Exchange documentation](#).

## 5.2. Ray Tracing Quality

---

By default, Studio shows a preview in Studio Designer quality. You can switch to the Ray Tracing Quality preview, by selecting **Ray Tracing Quality** in the fly-out menu of the Studio palette, or by selecting **Ray Tracing** in the Studio Window settings panel, if no part is selected.

**Ray Tracing** is a rendering technique for generating a 3D image by tracing the path of light rays and simulating the effects of its encounters with virtual objects. The technique is capable of producing a high degree of visual realism, but at a greater computational cost.

Ray Tracing quality combines the modelling of print and finishing effects from Visualizer quality with physically based photorealistic rendering. This rendering mode focuses on realism of both printable parts and non-printable parts and is meant for exporting photorealistic images and image sequences. Because of the heavy calculation requirements it is not suitable for interactive 3D viewing.

When switching to **Ray Tracing Quality** or when changing the view, the Studio window will show a progressive preview of your scene: at first very noisy but progressively clearing up. This should help you to frame your shot and tweak materials and lighting.



Note that the preview in the Studio window will not achieve the full quality of the final exported pack shot.

Below two examples of pack shots with Ray Tracing quality.



**Note:** When in Visualizer Quality or Ray Tracing Quality, certain (technical) inks will be ignored by the 3D Print Modeling. They will not be visible in the Finishing Operations palette, and will not be visible in the 3D preview or Export. See [Inks ignored in the 3D view](#) on page 144

## 5.3. Scene Settings

---

In the **Scene Settings** you can finetune the way your work looks in the Studio window.

You can open the Scene Settings dialog by choosing **Scene Settings** from the fly-out menu, or by clicking the **Scene Settings** link in the Studio Options.

If the **Preview** option is enabled, the Studio window will immediately reflect the changes you make in the Scene Settings.

All settings from the Scene Settings dialog are used in the Export dialog, except for:

- Floor Reflection and Background Image for PDF files with 3D design and U3D.
- Custom Lighting Environment for Collada export

### 5.3.1. Environment

In the **Environment** tab you can set different parameters.

#### Lighting Environment

The **Lighting Environment** is available if you are using Visualizer quality or Ray Tracing quality. See [Visualizer Quality](#) on page 143 and [Ray Tracing Quality](#) on page 145

You can select one of the predefined lighting environments. The regular **Environments** can be used in both Visualizer and Ray Tracing quality, while the **Legacy Environments** can only be used in Visualizer Quality.

You can also use a custom lighting environment by selecting **Load...** and open an OpenEXR high dynamic range panorama file (.exr). HDR files (.hdr) are not supported, but they can be converted to OpenEXR using third-party online tools, or in applications such as Adobe Photoshop.



**Note:** The Lighting Environment is embedded when saving a Scene Preset. See [Scene Presets](#) on page 150

When using a Lighting Environment in Visualizer quality or Ray Tracing quality, you can choose how the environment interacts with the scene **When changing the View**: either **orbit the camera** and keep the model at a fixed position in the lighting environment, or **spin the object** and keep the camera at a fixed position in the lighting environment. This second option mimics a photo studio setup.

When in Visualizer or Ray Tracing Quality, you can click and drag with the right mouse button to rotate the **Environment**. On Mac OS, you can also hold the Control key and click and drag. To only rotate the environment horizontally, you can hold the Shift key while rotating. Double-click with the right mouse button or double-click while holding the Control key to reset the environment orientation.

If you change from Visualizer to Ray Tracing Quality or vice versa, Studio will use the same Environment when possible.

- When the used environment is not available in the Quality you change to (e.g. you use a Legacy environment and change to Ray Tracing Quality), the default environment will be used instead.
- A Visualizer Quality scene preset created before version 22.03 containing a custom environment can't be used in Ray Tracing quality



- A Ray Tracing Quality scene preset created before version 22.03 containing a custom environment can be opened, but will take some time when switching to Visualiser Quality. For these presets, it can be more efficient to reload the .exr and save it as a new preset.

### Shadow Contrast

You can set the contrast in the shadows. By default, this is set to 50%.

In Ray Tracing quality this option is not available, since the depth of the shadows is determined by the lighting environment.

### Background

In all three qualities, you can set the background to a **color**. In Designer and Visualizer quality, you can also set the background to an **image**.



**Note:** The Background Image is embedded when saving a Scene Preset. See [Scene Presets](#) on page 150

## 5.3.2. Floor Effects

The second tab of the Scene Settings defines the **Floor Effects**: the **Floor Reflection** and the **Floor Shadow**

### Floor Reflection

In Designer and Visualizer quality, you can use the **Reflection Opacity** slider to determine how strong the reflection will be. 0% is no reflection at all.

In Visualizer quality, you can enable **Fade** to let the reflection fade out, based on the selected **Position in View** and **Size** sliders

In Ray Tracing quality, you can adjust the reflection using the **Floor Shininess** slider. It controls how rough or shiny the floor is. A more shiny floor results in more pronounced reflections, while a 0% shiny floor has no reflections at all.

### Floor Shadow

In Designer and Visualizer quality, you can use the **Shadow Intensity** slider to define how strong a shadow will be. At 0%, there is no shadow. The **Shadow Softness** slider allows to control how soft the shadow should be.

In Ray Tracing quality, you can enable or disable shadows using the **Enable Shadows** option. The environment will determine the shape and direction of the shadows in Ray Tracing quality.

## 5.3.3. View

In the **View** settings tab you can numerically set the view angles, pan and camera distance.

- Set the **Object Heading** and **Object Tilt** to define the position of the object
- Set the **Pan** and **Camera Distance** to define the position of the camera, or click **Fit in Window** to reset the pan to zero and automatically adjust the camera position so that the 3D view fits in the Studio Window.

- Set the **Perspective** by either defining the **Focal Length** (in mm) or **Field of view** (in degrees) of the camera.
- Enable **Keep vertical lines parallel** if you want to get the effect of a tilt shift lens. If enabled, the vertical lines in the pack shots remain vertical (without vantage point). You can use this to create images that are easier to combine afterwards in a 'line-up' image. If the tilt angle is very large it can lead to very unrealistic distorted perspective.

The **View Preset** dropdown allows to select one of the default settings, or any previously saved Preset.

You can save the current settings as a new preset by selecting **Save as** in the dropdown.

Select **Manage...** to open a separate dialog in which you can delete unnecessary presets.

The Scene Presets and View Presets folders can be found here:

- On Macintosh: Macintosh/Users/user/Library/Application Support/Esko/Studio/
- On Windows: C:\Users\user\AppData\Roaming\Esko\Studio\

You can exchange the Presets between different operators by copying the files to another computer. Since these Preset files embed the backdrop image and environment, there is no need to exchange any other files.

If you remove all Presets and restart Adobe Illustrator, the default Presets will be recreated.

If the WebCenter Connector plugin is installed, scene presets (.sts files) and View Presets (.stv files) can be saved to and loaded from WebCenter. When a preset is loaded, it is added to the "Recent from WebCenter" list. See also [Using Studio Designer and WebCenter Connector](#) on page 191

### 5.3.4. Scene Presets

The **Scene Preset** dropdown allows to select one of the default settings, or any previously saved Preset.



**Note:** Scene Settings contain the Environment, Floor Reflection and View.

You can save the current settings as a new preset by selecting **Save as** in the dropdown.

Select **Manage...** to open a separate dialog in which you can delete unnecessary presets.

The Scene Presets and View Presets folders can be found here:

- On Macintosh: Macintosh/Users/user/Library/Application Support/Esko/Studio/
- On Windows: C:\Users\user\AppData\Roaming\Esko\Studio\

You can exchange the Presets between different operators by copying the files to another computer. Since these Preset files embed the backdrop image and environment, there is no need to exchange any other files.

If you remove all Presets and restart Adobe Illustrator, the default Presets will be recreated.

If the WebCenter Connector plugin is installed, scene presets (.sts files) and View Presets (.stv files) can be saved to and loaded from WebCenter. When a preset is loaded, it is added to the "Recent from WebCenter" list. See also [Using Studio Designer and WebCenter Connector](#) on page 191

## 5.4. Scenes and Multiple Documents

The 3D object that you see in the Studio window is typically the combination of two files: The artwork from the current Illustrator document and the shape from the Structural Design file that is placed in that document.

However, sometimes you would like to make combinations of more than one Illustrator document or more than one Structural Design file. Some examples are:

- A box with inside and outside artwork
- A bottle with more than one label
- A tray containing 6 cans
- A complicated multi-piece display
- ...

This chapter describes the different mechanisms behind these workflows.

### 5.4.1. Alternative scenes

#### Load Scene

At the top of the Studio Window is the Scene dropdown box. Here you can see which Structural Design file is currently visible in the Studio Window. By default this is the same file that is placed in your document, but from this drop down you can load other Structural Design files.

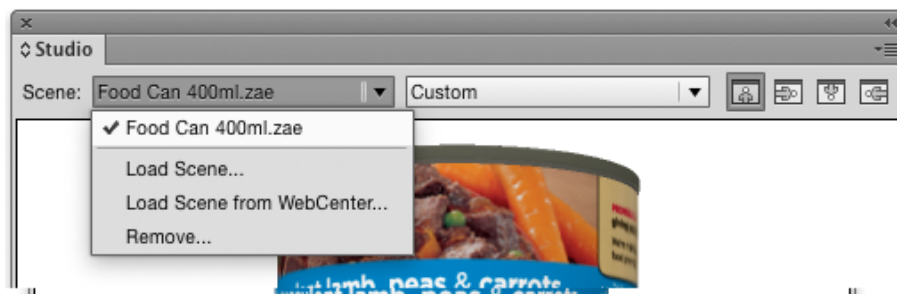

Your artwork will appear automatically on the loaded scene if the following conditions are met:

- There is a Structural Design file placed in the Illustrator document
- The selected scene has a printable part
- The printable part has the same size as the placed Structural Design
- The side (front or back) that is placed in the Illustrator document matches with the side of the printable part in the 3D file

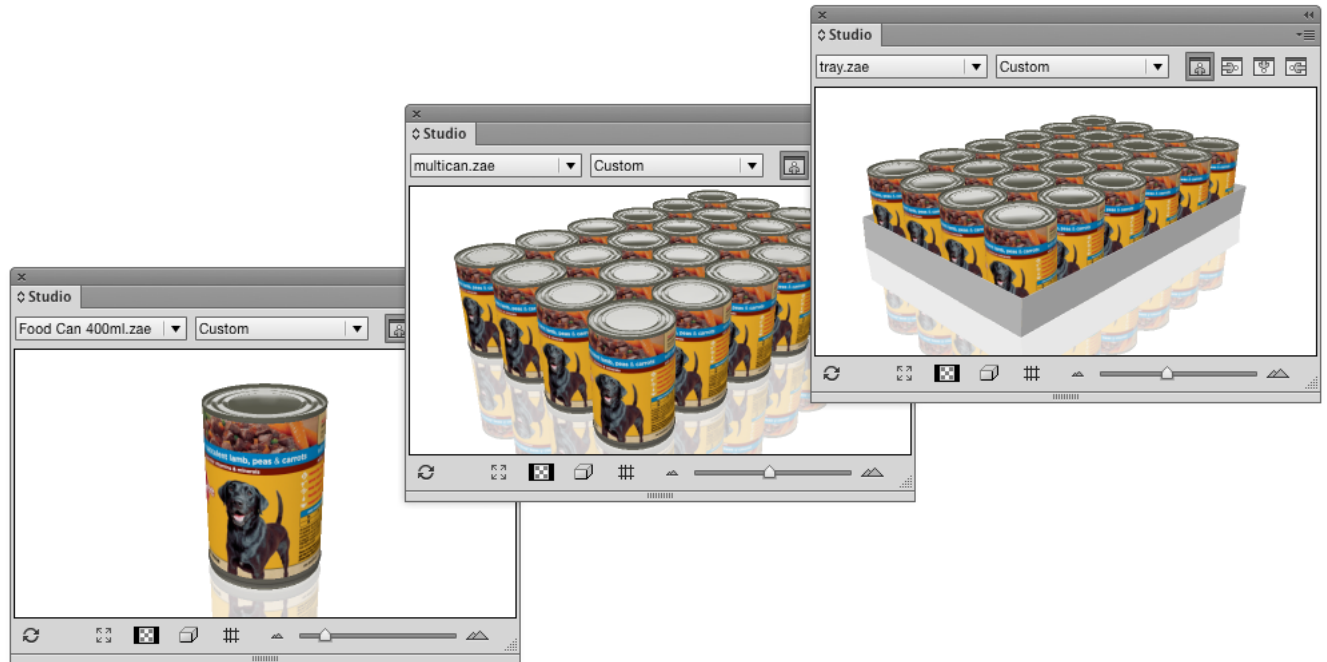
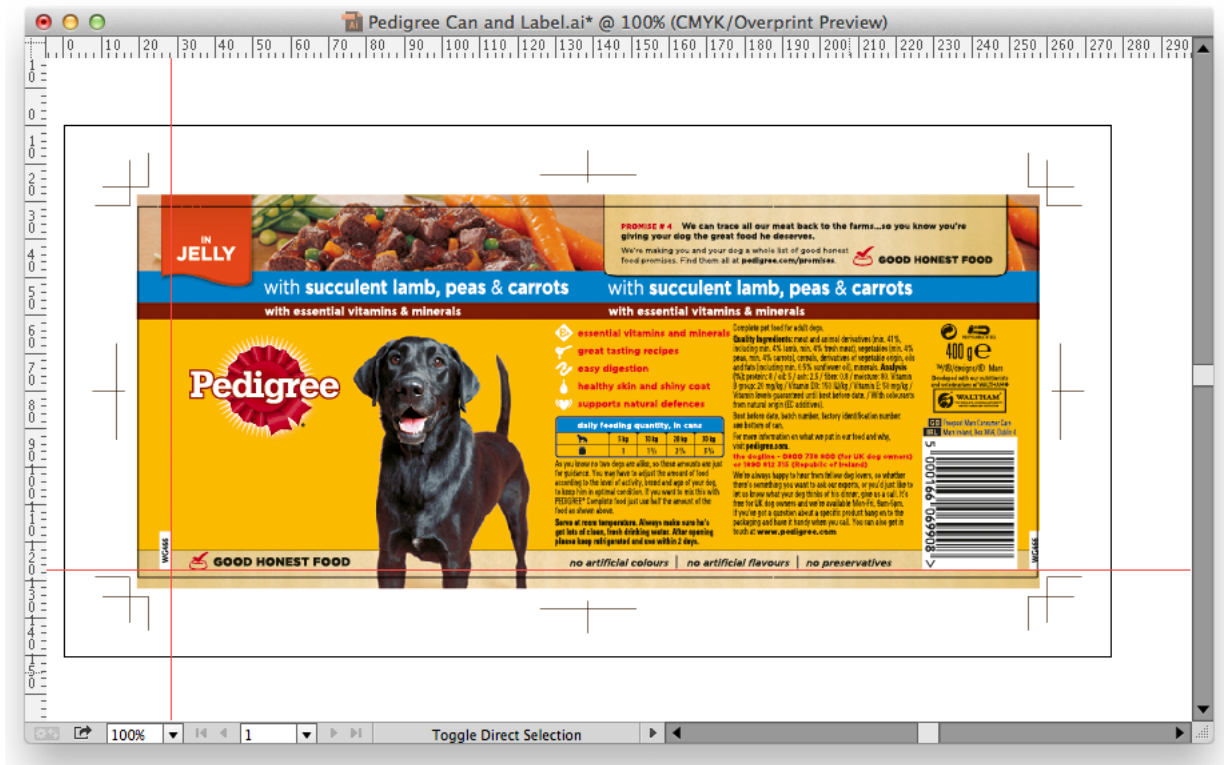

In this example, the placed Structural Design file is a Collada file of a single can. The two other loaded scenes are Collada files made in ArtiosCAD or Studio Toolkit, featuring that same can. You can switch quickly between the loaded scenes from the drop down list. This can help you to improve the artwork by seeing it in all of its different contexts.



**Note:** If you have the **WebCenter Connector** plug-in installed, you can use **Load Scene from WebCenter**. See [Using Studio Designer and WebCenter Connector](#) on page 191

## Remove Scene

You can remove items from the list by selecting **Remove....** This will free up memory but will not delete the files. The files that are placed in an Illustrator document cannot be removed, unless you close the document first.

## 5.4.2. Back side and Double-sided Artwork

When you place or open a Structural Design, it is loaded with the front side facing towards you (typically the outside of the box). The Studio window will show the artwork in this document on the front side of the board.

For ArtiosCAD Structural Design files you can also show artwork on the back side of the board (typically the inside of the box). Also for Collada files, if a printable part is double-sided, you can show artwork on the back side of the printable part.

Choose **Window > Esko > Structural Design > Show Structural Design Window**. The Structural Design window appears:

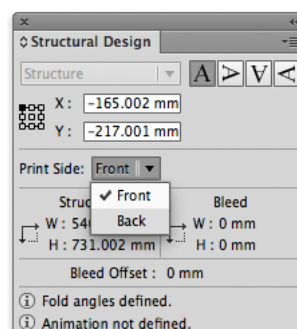

Choose **Back** in the drop down list of 'Print Side'. This will mirror the Structural Design layer and allow you to align your artwork to the back side. The Studio window will show the artwork on the back side of the board (typically the inside of the box).

The Studio Window can show artwork on both sides:

- The front and back artwork can be in two different documents or in the same document.
  - The document(s) must be open in Illustrator
1. Place and align a printable part of a Structural Design file with the front artwork.
  2. Place and align the same printable part (or a different printable part with the same size) with the back artwork, and set the Print Side to **Back**.

A fast and easy way to add graphics to the inside or back side, is to double-click the inside or back side panel in the Studio Window. You can choose to place the back side in the current document or in a new document.

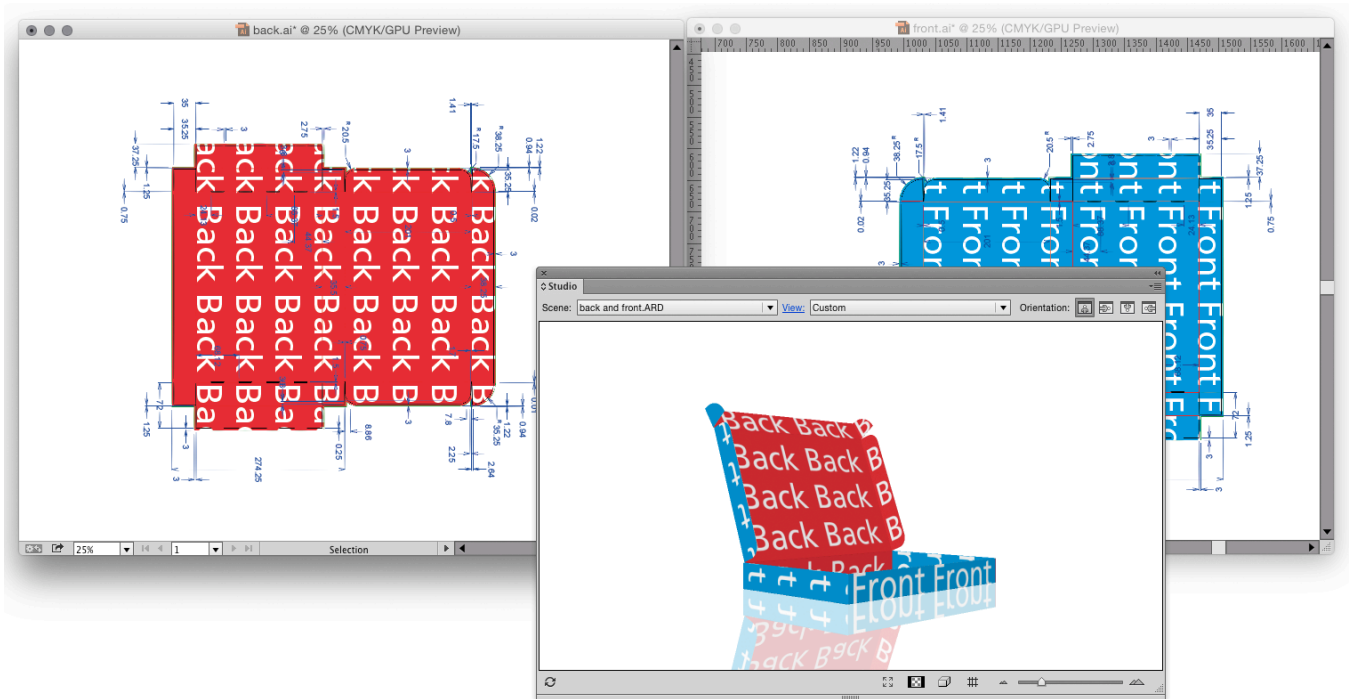

### 5.4.3. Collada files or ACD files with Multiple Printable Parts

Some of the Studio tools can produce Collada files with more than one printable part:

- A bottle with two labels, created by the Revolve and Add Labels tool. See [Revolve a profile and Add Labels in Adobe Illustrator](#) on page 99
- A combination of shapes in Studio Toolkit. See [Combining shapes in Studio Toolkit](#) on page 156
- ...

ArtiosCAD can also output structures with multiple printable parts. These are saved to an ACD file or a Collada file.

When you use a Collada file or an ACD file with multiple printable parts, you can choose to place one printable part, or to place all printable parts

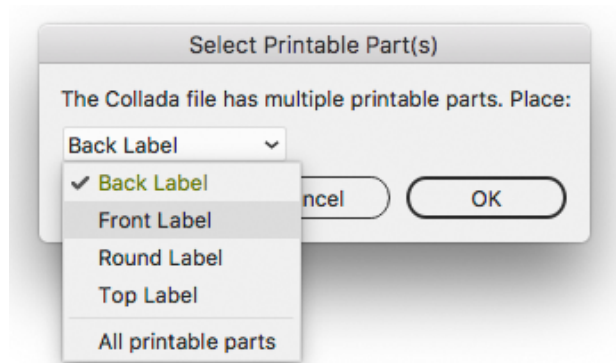

To see the object in the Studio Window with artwork on all the printable parts, you can organize your artwork in a different document for each part. Use the same Structural Design file in every document and select the corresponding part.

Alternatively, you can combine some or all printable parts in the same document: you can place the Structural Design file and select "All Printable Parts", or place the Structural Design file once for every printable part you want to include.



**Note:** If you have multiple printable parts in the same Illustrator document, all those printable parts will use the same finishing operations and substrate. See [Finishing Operations](#) on page 162

When all the documents are open, the Studio window will automatically show the different documents as artwork on the different parts:

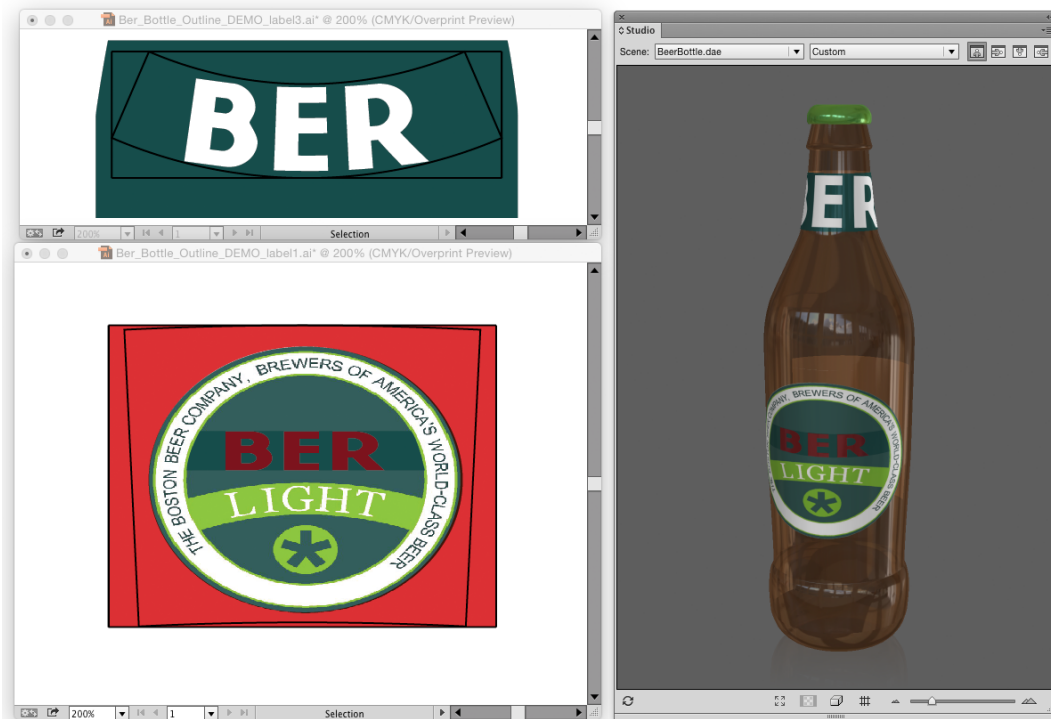

**Tip:**

If you don't have any artwork yet, then you can double-click the different printable parts in the Studio window and select **New** to create a new document for that part, or you can select **Place** to add it to the current document.

Another option is to open (instead of place) the Structural Design file multiple times. However, make sure to save each document before opening the collada file a second time, or you might get this message:

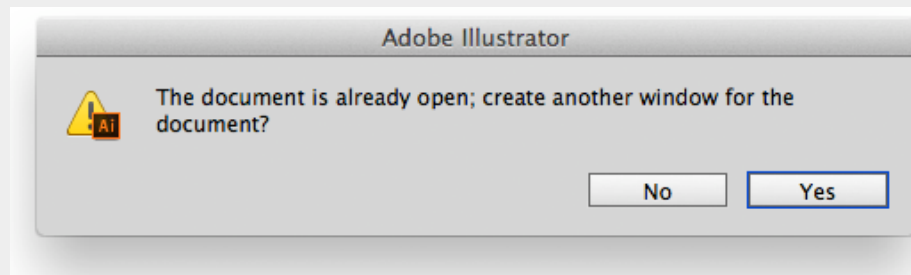

### Combining shapes in Studio Toolkit

You can combine different shapes in Studio Toolkit

- Using **Import Into** when you already have a shape in your Studio Toolkit job. See [Importing Shapes, Images or Paths](#) on page 53
- By repeating a shape. See [Repeat](#) on page 65
- By adding a sleeve to a shape or composition of shapes. See [Working with Shrink Sleeves](#)

You can for example combine a tray and a repetition of a can, resulting in a Collada file with multiple printable parts.



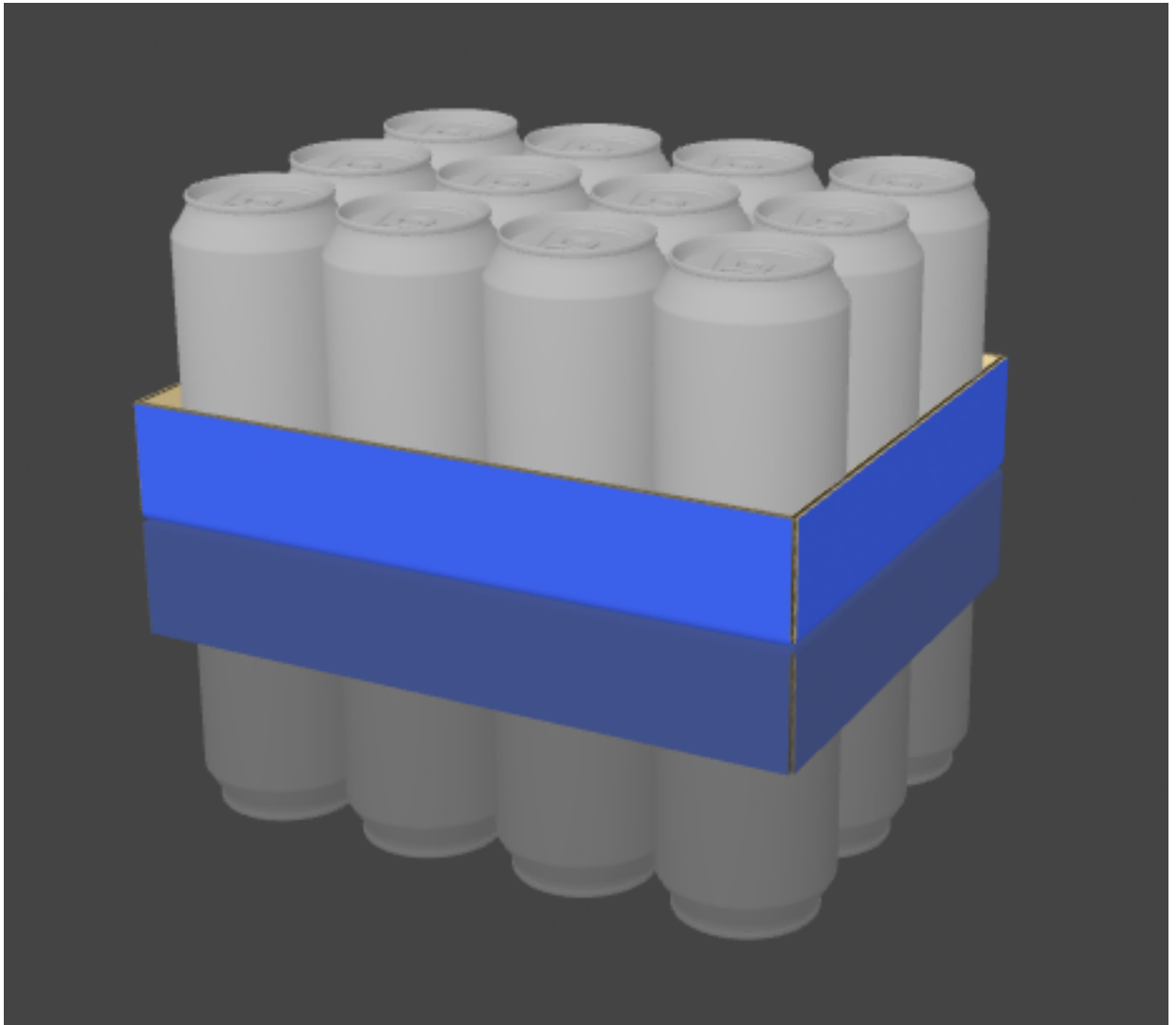

**Note:** If you use a shape for which you already created artwork in your composition, you can export a preview of this artwork in Adobe Illustrator, and apply it on the shape in Studio Toolkit. See [Using graphic files](#) on page 54 and [Save Graphics Preview as PNG...](#) on page 55



**Note:** You can use different Preview Colors for the different imported ARD files, to get a clear visible distinction in Studio Toolkit. See [Preview Color](#) on page 56

#### 5.4.4. Multi-part structures from ArtiosCAD: ACD or Collada files

In ArtiosCAD you can also build structures with more than one printable part, saved either as an ACD file or a Collada file.

When working on a multiple parts design in ArtiosCAD, the most straightforward and recommended approach is to save this multiple part design as an ACD file.

Be aware that if your design contains imported shapes, those imported shapes will not be included in the ACD file. For example in the picture below, the watch and pen will not be saved in the ACD file.

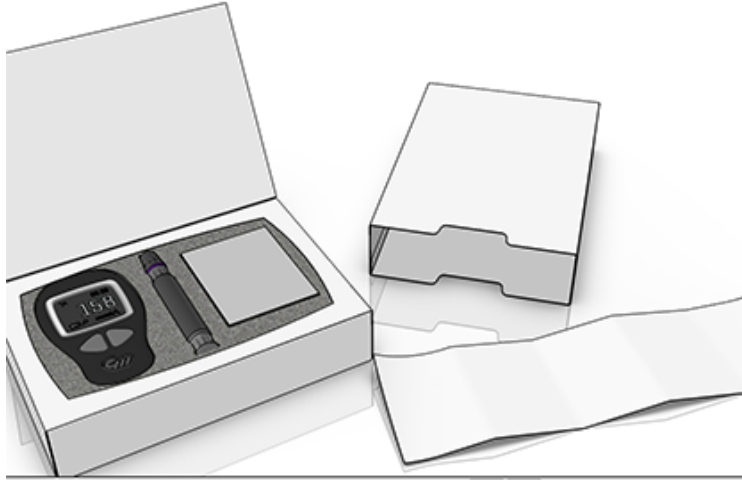

To include those shapes, you can use the Collada file creation tool from the 3D scene in ArtiosCAD instead.

### Reboard

Another reason to use Collada file instead of ACD, is to have a proper visualization of reboard. In the ACD file, a reboard looks like a corrugated carton.

In this case, use both the ACD and the Collada ZAE file in Studio Essentials:

1. Place the printable parts of the ACD file in one or more Illustrator documents. See [Collada files or ACD files with Multiple Printable Parts](#) on page 154
2. Apply graphics to all printable parts. Using the ACD file will enable you to use the Distribute function while designing the graphics. See [Creating Copies with the Distribute command](#) on page 125
3. To get the final result, load the Collada file as a scene. See [Load Scene](#) on page 151

The graphics from the Illustrator document(s) containing the ACD file will be mapped onto the Collada ZAE scene.



### 5.4.5. Navigating between the different Illustrator documents

When multiple Illustrator documents supply artwork to the same scene, you can double click any of the parts in the Studio window to make the corresponding Illustrator document active. (See also [Zooming in on Panels in the document window](#) on page 123)

If you click on a printable part for which there is no Illustrator document open, you will be asked to either create a new document for that part or place that part in the current document. The same options are available in the options panel when the printable part is selected.

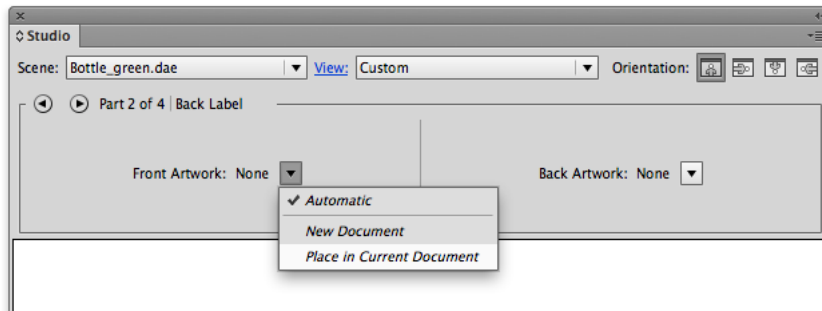

### 5.4.6. Different graphics on shapes of the same size

In some cases, especially when loading a scene, Studio will try to display the correct artwork on different printable parts or panels, preferably based on the name of the printable part, otherwise based on the size of the printable part. However, in some cases, you might want to manually change the graphics used for a specific printable part.

If you e.g. have two designs, using the same Structural Design file, loading a scene of a composition will place the same (active) Illustrator design on all instances in the composition.

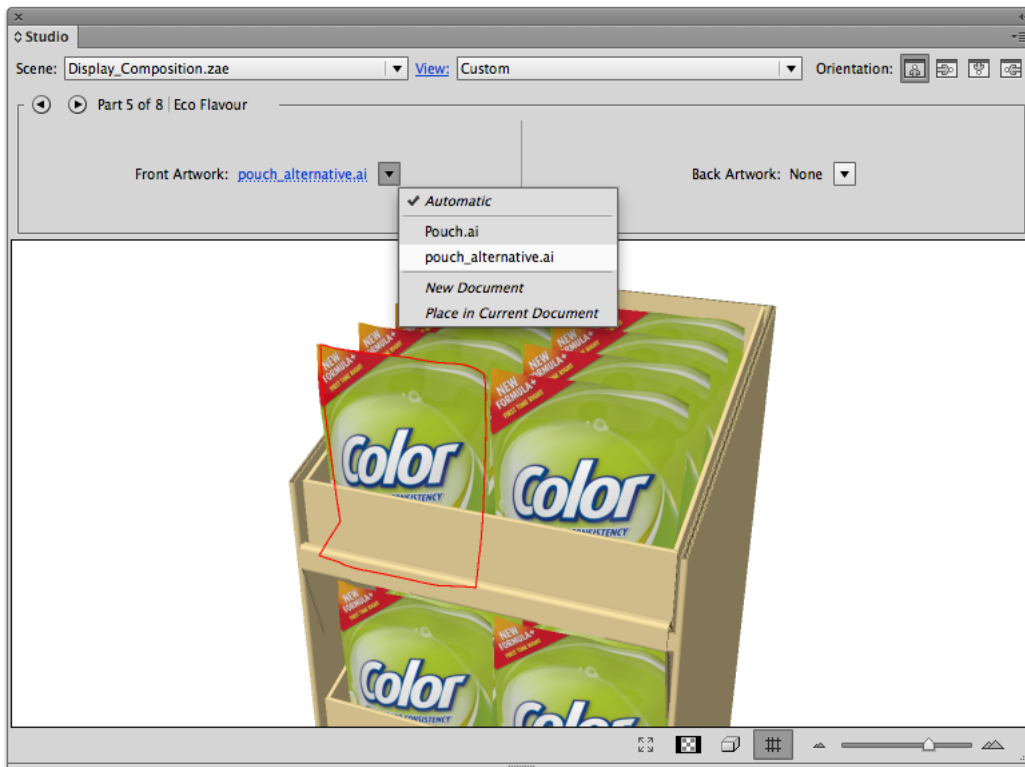

After selecting the printable part you want to change, you can click the dropdown menu for the Artwork in the options panel. The drop down list shows a list of all compatible open Illustrator documents. An Illustrator document is compatible if it has a placed printable part with the same size as the selected

shape in the Studio window, and the side (back or front) placed in the Illustrator document is the same as the selected side of the printable part. You can either select the Illustrator document you want to use, or create a new document.



**Note:** If a document contains more than one printable part that is compatible, the document will appear multiple times in the dropdown.

If your composition is made in Studio Toolkit, it is important to know that if you use the **Repeat** function, all instances will share the same printable part, and thus will share the same graphics. In the example underneath, the left side pouches use the same printable part, while the right side use another.

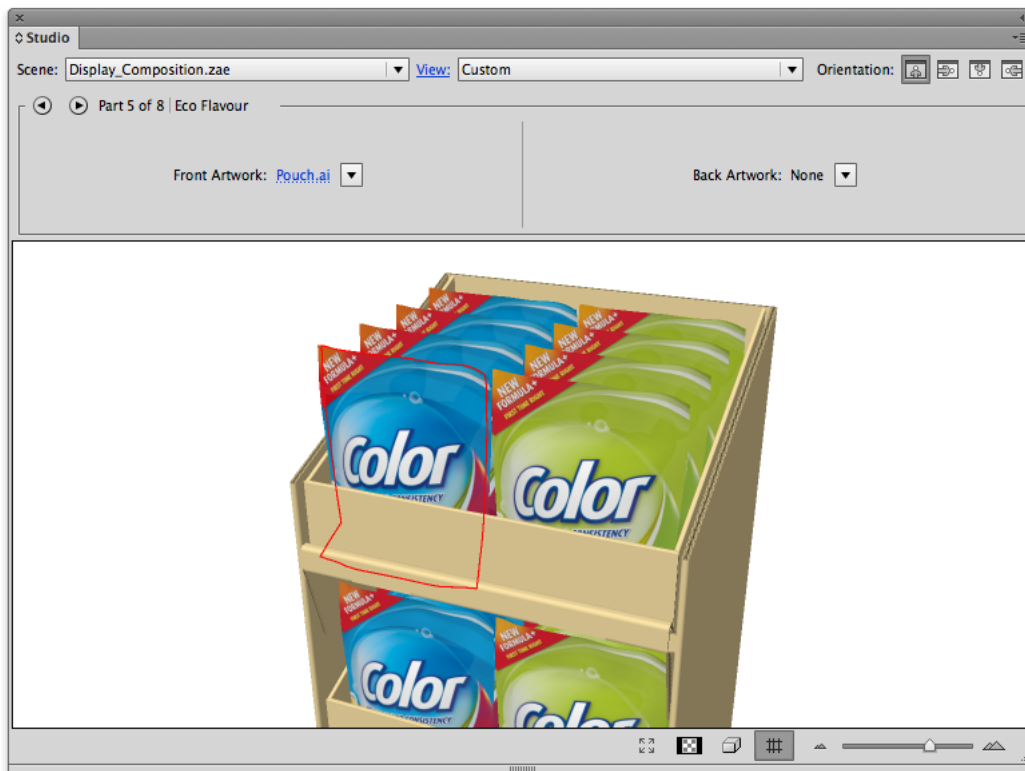

You have two options to create such a composition in Studio Toolkit:

- Import the single shape twice. Although they will have the same name (i.e. the name of the Structural Design file you imported), these shapes will have a different printable part, so you will be able to apply different artwork on them.
- Create copies of the single shape file, and import them both in your composition. This will have the advantage that the printable parts will have different names, based on the file name of the single shape you imported.

## 5.5. Finishing Operations

---

In combination with the Visualizer quality or Ray Tracing quality preview, the Finishing operations allow to get a realistic preview of special operations, such as varnishing, metal foils, special inks, etc.

For more information on Visualizer quality, see [Visualizer Quality](#) on page 143. For more information on Ray Tracing quality, see [Ray Tracing Quality](#) on page 145

Finishing operations can be applied to the complete design (full coverage), or applied locally, based on graphical art using a specific swatch. See [Finishing Operations and swatches](#) on page 162



**Note:** If you have multiple printable parts in the same Illustrator document, all those printable parts will use the same finishing operations and substrate. If you want to use a different set of finishing operations or substrate, you should place the printable parts (and corresponding artwork) in different Illustrator documents.



**Note:** Iridium effects and Holographics are not supported in Ray Tracing quality.

### 5.5.1. Finishing Operations and swatches

Finishing operations can be applied locally, based on graphical art using a specific swatch. You can either convert an existing spot into a finishing operation, or you can create a new finishing operations, which will create a new swatch.

#### Finishing Operations to swatches

When creating a new Finishing Operation, a spot color swatch will be generated.

If you change this swatch afterwards, the representation in Adobe Illustrator, and in the Studio palette using Designer quality will be changed accordingly. The preview in Studio using Visualizer quality or Ray Tracing quality will not change.

#### Swatches or spot colors to Finishing Operations

When opening a file containing spot colors, or when creating a new swatch using the Adobe Illustrator tools, Visualizer will try to automatically recognize it, and map it onto a correct Finishing Operation, and put it in the most logical order.

For example:

- A swatch "Gold Foil" will result in a Finishing Operation "Gold Cold Foil"
- A Pantone color will result in a corresponding Pantone Finishing Operation
- A custom spot color that doesn't match another Operation, will result in a Finishing Operation "Spot Color"



**Note:** When doing this automatic swatch recognition, Custom Operations will take priority over standard operations. See [My Operations](#) on page 170 for more information on Custom Operations.

### 5.5.2. The Finishing Operations palette

You can open the **Finishing Operations** palette by selecting **Window > Esko > Studio Visualizer > Show Finishing Operations**. This palette allows to make and change all finishing operations, substrate, etc.

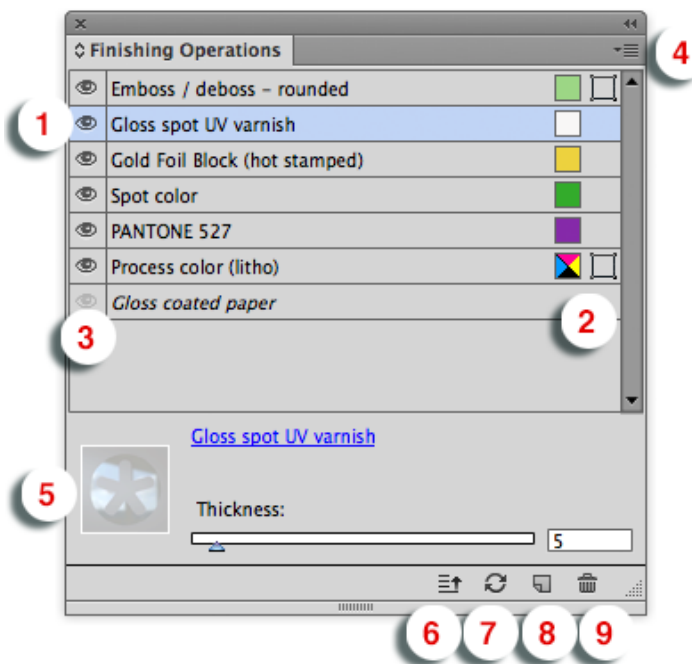

1. The palette contains a list of all Finishing Operations set in the job (the "Operations Stack"), and the substrate. You can click and drag operations to change the order.
2. Next to the Finishing Operations, you can see the **Swatch button** (left) and the **Artwork Selection button** (right).
  - You can click the **Swatch button** to apply the swatch to the currently selected objects.
  - You can click the **Artwork Selection button** to select the artwork currently using the selected operation. If the operation is not used, the Artwork Selection button will not be available
  - There will be one Process Color Swatch if one of the process colors is used in the job.



**Note:** It is strongly advised NOT to replace the CMYK operation by another operation.

- If a Finishing Operation uses full coverage, none of these buttons is shown, and its name is italic.
3. The Operation Visibility toggle. After refreshing, the finishing effect that are set to invisible will be ignored in the 3D preview. Also when exporting, invisible finishing operations will be ignored. You can't change the visibility of the substrate operation.
  4. The fly-out menu

5. You can change the **Detailed options** for the selected Finishing Operation. You can show or hide this options by selecting **Show / Hide Detailed options** from the fly-out menu.
6. You can click the **Optimize Operation Order** button, or select the corresponding option in the fly-out menu, to rearrange the Finishing Operations in the most logical order.
7. Click the **Update Operation List** button, or select the corresponding option in the fly-out menu, to update the Operation List after changing e.g. the swatch color in Adobe Illustrator.
8. Click the **Add Operation** button, or select the corresponding option in the fly-out menu, to create a new Finishing Operation.
9. Click the **Delete Operation** button, or select the corresponding option in the fly-out menu, to remove an operation from the list



**Note:** When in Visualizer Quality or Ray Tracing Quality, certain (technical) inks will be ignored by the 3D Print Modeling. They will not be visible in the Finishing Operations palette, and will not be visible in the 3D preview or Export. See [Inks ignored in the 3D view](#) on page 144

## The Operation Order

### Move an Operation Up or Down

The operations in the **Operation Stack** may be re-ordered if so desired. The changes in order will be reflected in the 3D view of your model. The higher the operation appears in the **Operation Stack**, the later it is applied in the virtual printing process.

1. Select the operation you want to move in the **Operation Stack**.
2. Click the **Move Operation Up** or **Move Operation Down** buttons until the operation is in the desired



3. Drag the operation to the desired position

### Optimize Operation Order

The **Optimize Operation Order** function will reorder all operations in the most logical order. You can apply the function by clicking the **Optimize Operation Order** button  or by selecting **Optimize Operation Order** from the fly-out menu.

## 5.5.3. Set the Substrate Material

A substrate material is always the first operation for each model. It is represented by a specific substrate operation appearing at the bottom of the stack.

Substrates can be selected and changed in the **Change Substrate** dialog. This Operation Selector will only show materials or operations that can be used as a substrate.

1. Open the **Change Substrate** dialog.
  - Double-click a substrate operation, or
  - select **Change Substrate...** from the fly-out menu, or
  - select **window > Esko > Studio Visualizer > Change Substrate...**



2. Disable the option **Use the substrate from the structural design file**.

If the option **Use the substrate from the Structural Design file** is enabled, the substrate information from the Structural Design file will be used. If a Structural Design file is loaded, the substrate material is shown within parentheses. If there is no Structural Design file, a gloss coated paper will be used. If multiple printable parts are placed in a single Illustrator document, the substrate is taken from the first printable part that was placed in the document.



**Note:** You can always return to the substrate defined in the Structural Design file by enabling this option again.

3. Select the Substrate you want to use in the Operations tree on the left hand side.



**Note:** As an alternative to browsing through the Operations tree, you can type the first letter(s) of the operation you want to apply in the search field at the top of the dialog.

The **Change Substrate** dialog now displays the properties for the selected operation in the right panel:

- the **Color Picker** displays the substrate color,
  - any additional parameters (for example a slider controlling the texture depth of the paper)
  - a basic description of the substrate
4. Click OK to apply the substrate material to the model.

The model now has a substrate applied to it, and the **Studio** window displays the result when in Visualizer quality or Ray Tracing quality.

## 5.5.4. Add a new Finishing Operation

To add a Finishing Operation:

1. In the **Finishing Operations** palette, either click the **Add Operation** button  or select **Add Operation** from the fly-out menu

The **Operation Selector** dialog appears. See [The Operation Selector in Detail](#) on page 166

2. Browse to the operation you want to apply.
3. If applicable, set the available parameters, and click **OK**
4. Define the **Scope** for the operation:
  - Select **Add swatch** if you want to apply the operation locally, based on graphical art using a specific swatch
  - Select **Apply full coverage** if you want to apply the operation on the complete design

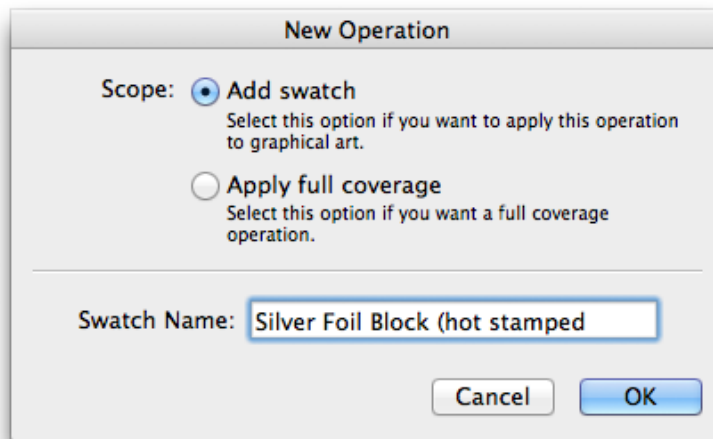

**Note:** Some operations, such as lamination, do not allow local application, so the **Add swatch** option is disabled.

The newly created Finishing Operation will appear in the Operations list, at the most logical position.

In case "Add Swatch" is selected, a swatch with the same name as the Operation will be added to the Adobe Illustrator Swatches. By applying this swatch to (new or existing) objects in your file, you can define the area(s) where the finishing operation needs to be applied.

### The Operation Selector in Detail

Operations are representations of the print effects and finishes that may be applied to your Studio Visualizer models. The **Operation Selector** dialog, in combination with the **Artwork Selector** dialog, provide a means of choosing operations to apply to your model.

The **Operation Selector** is shown when you are adding a new operation to your model, or editing an operation that is already being used in your model.

Components of the Operation Selector

Add Operation

Library materials

Spot Color

Foil Block (hot stamped)

Foil Block (hot stamped)

ed Foil Block (hot stamped)

Foil Block (hot stamped)

Cold Foil

Cold Foil

ed Cold Foil

ase and Die Cut

ug-in

CHING SYSTEM®

Guide

ings

allic inks

® - Special Effects for

**NISON** Label and Pack

NE® Sampler

5

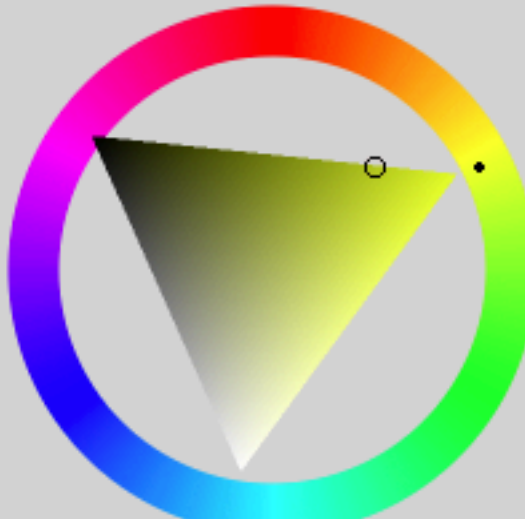

System Picker

RGB

HSV

Lab

R

G

B

Stamping Pressure

0 100

Found in Esko Standard Library > [Foil](#)s



**Colored Foil Block (hot stamped)**  
hot stamped colored foil block

<http://www.esko.com/>

Cancel

1. *Operation finder tool*
2. *My Operations*
3. *Operations tree view*
4. *Color picker, Operations folder view, or Operation preview*
5. *Operation parameters area*
6. *Information area*
7. *Add to My Operations button*

The **Operation Selector** organizes all the operations available in to a hierarchy. On the left hand side of the **Operation Selector** dialog, the operations tree view presents this hierarchy in the form of a tree. Here you can expand folders and browse for an appropriate operation to apply to your model.

You can store frequently used operations with fixed settings in **My Operations**. See [My Operations](#) on page 170

Below the operations tree view, there is an **Information** area, which will often provide you with a brief explanation of the currently selected operation, as well as providing some appropriate clickable links through which you may find out more information about the operation at hand.

In the lower right-hand corner of the operation selector window there is an **Operation parameters** area. In here, any parameters pertinent to the currently selected operation are shown and may be modified by using the slider or the text-entry box.

The upper portion of the right hand side of the operation selector window displays context-dependent information and controls that are related to the currently selected entry in the operations tree view. There are three possible things that might appear in this area:

- The Color Picker;
- The operations folder view;
- An operation preview.

### The Color Picker

#### Color wheel

The color picker appears in the right-hand side of the operation selector window when an operation is selected in the operations tree view that requires a color in order to fully define it.

The most striking feature of the color picker is the color wheel. To select a color, you may click anywhere in the color wheel's ring to choose your desired hue. The triangle will change accordingly to show the full range of saturation and value levels for that hue.

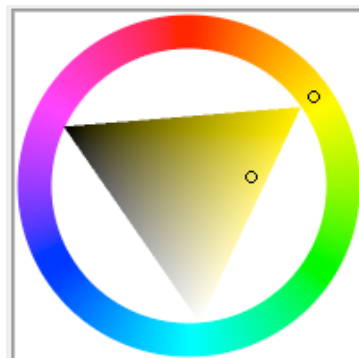

**Tip:**

Some tips for using the Color Picker:

- HSV, RGB and Lab are color spaces: different ways of representing a color using a combination of numerical values. You may change between HSV and RGB sliders by clicking on the tabs provided.
- RGB is a color space that you may be familiar with - it defines color as a combination of Red, Green and Blue values. HSV stands for Hue, Saturation, Value. If you are unfamiliar with the HSV and Lab color spaces, you can use the RGB sliders.
- Colors entered in the Lab tab represent CIE Lab values with a D50 white-point and 2 degree observer.



**Tip:** If you prefer, your operating system's native color picking tool may be used by clicking on the **System Picker** button.

On top of the window, there is a block of color. The top half of the block displays the color that was displayed when the color picker was first shown. The bottom half of the block displays the color that is currently selected. Double clicking on the top half of the color block will restore the color picker to the color that was originally shown.

These color blocks make it easy to see the effects of small changes made to a given color.

### Color palette

Below the color blocks is a color palette. The color palette may be employed to store colors that are used frequently throughout your project for easy access. To add a color to the palette, you may drag-and-drop colors from the color blocks in to the desired cell of the palette. Also, clicking on the lower color block adds the currently displayed color to the first non-white cell of the palette (or the first cell if there are no white cells available). Colors may be dragged between palette cells for further organization.

### The Operation Folder View

When an operations category is selected in the operations tree view (or when nothing at all is selected), the right hand side of the operation selector window will display the contents of the category in question. This may contain further operations sub-categories or actual operations.

You can think of the operations tree view and operations folder view as a kind of file browser (as found on Microsoft Windows or Mac OS X); the operations tree view provides an overall picture of the layout and high-level navigation facilities, whereas the operations folder view provides a more up-close approach to navigation.

This browser analogy is furthered by the **Browse Back**, **Browse Forward** and **Browse Up** buttons.

Clicking on the icons within the operations folder view will navigate further down the operations hierarchy. If an operation is clicked, you will be presented with either the color picker (detailed above) if the operation requires a color or a preview image of the operation in question.

### Operation Preview

When an operation has been selected in either the operations folder view or operations tree view, you will be shown a preview image that visually describes the effect of the operation.

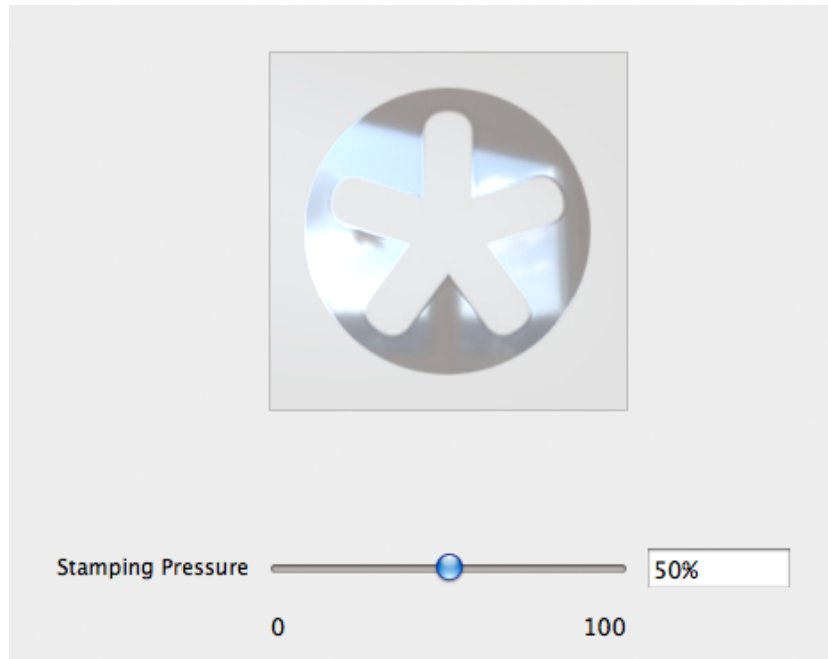

If an operation is selected that makes use of a color, the color picker will be shown instead of a preview.

### My Operations

The **My Operations** category, at the top of the operations tree view, contains **custom operations**.

A Custom Operation is a standard operation, stored with its specific parameters in the My Operations category.

Using Custom Operations can offer many benefits:

- You can make your most frequently used operations easy accessible, and reduce setup time
- You can make sure the same (correct) parameters are used every time. You can even share these amongst different users.
- Since Custom Operations take priority over standard operations during automatic swatch recognition (see [Finishing Operations and swatches](#) on page 162), you can use Custom Operations to fine-tune this process, making sure the correct parameters are used.
- To create a Custom Operation:
  - a) Select any standard operation, and set the parameters you want to use and store.
  - b) Click the **Add to My Operations** button in the bottom right corner
  - c) Add a name and (optionally) extra info about the operation.

The Operation, with all its settings and parameters, will now be available in the **My Operations** section

- To use a Custom Operation, select it from the My Operations category



**Note:** Since all parameters are stored in the Custom Operations, you will not be able to change any settings.

- To remove a Custom Operation from the My Operations category, select it and click the **Delete** button in the bottom right corner.

- To share Custom Operations, you can copy the "My Operations" folder from one computer to another.

The location of the My Operations folder:

- On Mac: `/Users/Shared/EskoArtwork/Visualizer/v1/ExternalResources/XMLOperations/`
- On Windows: `C:\Users\Public\Documents\EskoArtwork\Visualizer\v1\ExternalResources\xmloperations\`

### 5.5.5. Finishing Profiles

A **Finishing Profile** contains an **Operation Stack** (a set of Finishing Operations in a specific order).

A **Finishing Profile** can be useful if several artwork files require a similar Operation Stack to visualize the packaging artwork:

- the same substrate
- the same finishing effects, using consistent names for the swatches and spot colors
- the same order of finishing operations.

You can export a Finishing Profile based on the **Operation Stack**. See [Exporting a Finishing Profile](#) on page 171

You can then apply this Finishing Profile on a different artwork file in Adobe Illustrator (see [Importing a Finishing Profile](#) on page 172) or you can use the Finishing Profile in an automated workflow in WebCenter.

If the WebCenter Connector plugin is installed, Finishing Profiles can be exported to and imported from WebCenter. See also [Using Studio Designer and WebCenter Connector](#) on page 191

#### Exporting a Finishing Profile

To export a **Finishing Profile**:

1. Open the **Finishing Operations** palette by choosing **Window > Esko > Studio Visualizer > Show Finishing Operations**
2. In the Fly-out menu of the palette, select **Export Finishing Profile...**

The Export Finishing palette will open.

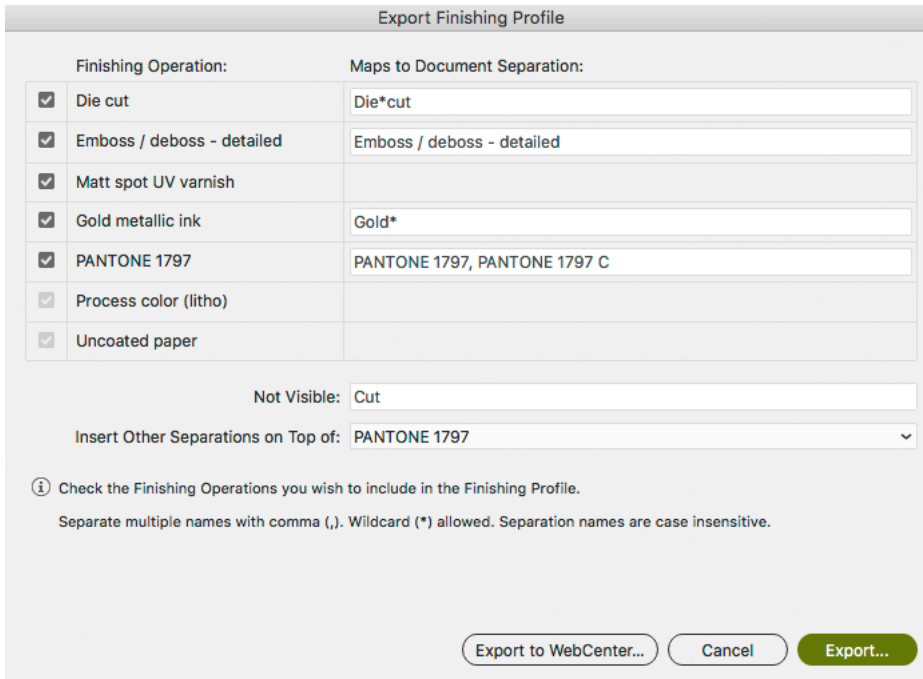

- Using the checkbox in front of the name, you can select or deselect Finishing Operations to decide if you want to include them in the Finishing Profile.



**Note:** The Process color operation, Substrate operation and "Not Visible" settings are always exported

- Set the separation names for each operation. You can enter multiple separation names separated with a comma. By using wildcards you can match multiple separation names to an operation.
- Set the **Not Visible** operations. Any separation that matches one of these rules will be set invisible in the Finishing Operations palette.
- Use the **Insert other spot colors on top of** dropdown to decide the position to put spot color separations that don't match any of the operations set in the Finishing Profile.
- Click **Export** to save the Finishing Profile as a .stf file.

### Importing a Finishing Profile

To import a Finishing Profile:

- Open the **Finishing Operations** palette by choosing **Window > Esko > Studio Visualizer > Show Finishing Operations**
- In the Fly-out menu of the palette, select **Import Finishing Profile...**
- Browse to the saved Finishing Profile and click **OK**

When you import a Finishing Profile:

- The Substrate is changed to the substrate defined in the Finishing Profile.
- If a spot color in your document matches any of the spot colors defined in the Finishing Profile, the spot color will be mapped onto the corresponding Finishing Operation.
- If a Finishing Operation in the Finishing Profile doesn't exist yet, it will be created and the corresponding swatch and spot color is added.



4. The Finishing Operations are placed in the same order as in the Finishing Profile.
5. Other spot colors that are used in the document are added above the Finishing Operation as defined in the Finishing Profile.
6. Finishing Operations matching the "Not Visible" list are set to invisible in the Finishing Operations panel.

## 5.6. Tips&Tricks: Using a Diecut operation

---

A Diecut operation is an operation that cuts away everything that lies outside (or inside) a path. This can be very useful in a number of situations:

- A label created using **Revolve and Add Label** is always rectangular. Using the Die cut operation, you can apply a different shape of label. See [Tips&Tricks: Die cut operation on a label](#) on page 106
- When adding a Freeform label in Studio Toolkit, it's not always possible to draw the label the exact shape and size that you would like. You can use the Die cut operation to trim the label to the intended shape and size. See [Tips&Tricks: trim a Freeform label](#) on page 95
- If you want to create tear notches, rounded corners, zigzag cuts or hole in a flexible bag design, you can use the Die cut operation. See [Tear notches, rounded corners and zigzag cuts](#)

Adding a Die Cut operation works the same way as for any other finishing operation. See [Add a new Finishing Operation](#) on page 165

When creating the Die Cut Operation, make sure to select **Add swatch**.

If you select **Die Cut Operation**, the objects using the Die Cut swatch will define the areas that are **cut away**. If however you use a **Die Cut Operation (Inverted)**, the objects using the swatch will define the areas that are **kept**.

## 5.7. Tips & Tricks: Clear substrates and White Underprint

---

When working with a clear substrate, such as plastic film, or with a metallic substrate, you may want to add an opaque white ink under certain printed areas. You can do this by adding **White Underprint**



**Note:** Transparent substrates only render correctly in **Visualizer Quality**. See [Visualizer Quality](#) on page 143

1. If not set correctly in the Structural Design File, you can modify the substrate to a clear substrate in the **Finishing Operations**. See [Set the Substrate Material](#) on page 164.
  - a) In the **Finishing Operations** panel, double-click the **Substrate** (the bottom line in the list).
  - b) Disable **Use the substrate from the Structural Design file**
  - c) Select the substrate you want to use, e.g. Transparent OPP Film, and



**Note:** You can change the transparency of non printable parts in the Studio Window. See [Non Printable Part options panel](#) on page 116

2. Create the **Opaque White Spot Color** operation. See [Add a new Finishing Operation](#) on page 165. Select **Add Swatch**

3. Use the **Optimize Operation Order** button  to position the Opaque White Spot Color operation between the substrate and the other colors.
4. Create the White Underprint objects on top of the other artwork. Make sure you enable **Overprint Fill** in the **Attributes** panel.



**Note:** When available, you can use Esko's White Underprint plugin to easily create the objects you need.

You can also use White Underprint when working on Metallic surfaces.

## 6. Step 4: Share

---

Studio Essentials offers a variety of export options to a number of common formats.

- A static Pack Shot of the 3D view: See [Export Image](#) on page 175
- An animated sequence of TIFF images. See [Export Image Sequence](#) on page 178
- A Collada file, that can be used in another Studio application such as Studio Toolkit or Store Visualizer, or in a 3rd party 3D application, or in an Esko Viewer. See [Export Collada File](#) on page 181
- A KeyShot file (.bip), a common exchange format for 3D models. See [Export KeyShot](#) on page 182
- A dynamic 3D PDF or U3D file, allowing the viewer to freely rotate the 3D representation. See [Export a 3D PDF or U3D File](#) on page 183
- A binary glTF file. glTF is a standard file format for 3D scenes and modals, and can be used in various applications, e.g. Microsoft Office. See [Export a Binary glTF](#) on page 185

The background color and other settings defined in the Scene Settings will show up in your exported file.

**Note:**

If you have the **WebCenter Connector** plug-in installed, you can set **Save to:** to **WebCenter** to upload the exported file directly to WebCenter. See [Using Studio Designer and WebCenter Connector](#) on page 191

When you're exporting a Collada file or an Image, you can set **Save to:** to **Share & Approve (Esko Cloud)** to upload the exported file directly to Esko Cloud. See [Using Studio Designer and Esko Cloud Connector](#) on page 191



**Note:** When in Visualizer Quality or Ray Tracing Quality, certain (technical) inks will be ignored by the 3D Print Modeling. They will not be visible in the Finishing Operations palette, and will not be visible in the 3D preview or Export. See [Inks ignored in the 3D view](#) on page 144

### 6.1. Export Image

---

Studio Designer can export the 3D design to an RGB JPEG, PNG or TIFF image with the graphics on top (much like the Studio window but at higher resolutions).

1. Choose **Export...** from Studio's fly-out menu. Choose **Image** as export type.

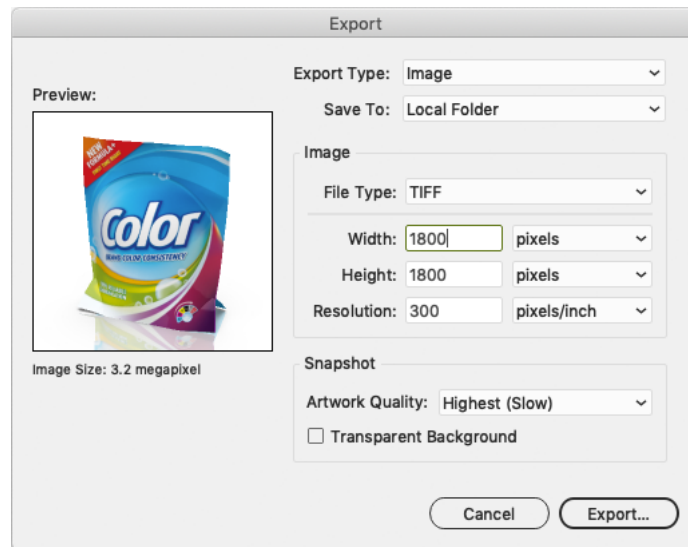

2. When exporting an Image in Ray Tracing Quality, you can set the **Render On**: you can choose if the rendering should be done on your local computer or should be offloaded on Esko Cloud. See [Render Packshots on Esko Cloud](#) on page 192



**Note:** When in Ray Tracing quality, the preview image in the Export dialog will be in Visualizer quality

3. Define where to save the result in the **Save To**: choose Local Folder, Esko Cloud or WebCenter. See [Using Studio Designer and WebCenter Connector](#) on page 191 and [Using Studio Designer and Esko Cloud Connector](#) on page 191
4. Set the **File Type**: TIFF, JPEG or PNG.
5. If File Type is set to JPEG, you can set the **Quality**: Low, Medium, High or Maximum. A higher quality will result in a larger file, while lower quality will allow more compression and thus a smaller file size.
6. Define the **Width, Height** and **Resolution** for the image that you want to export.
7. Define the **Artwork Quality**. Depending on what the image is needed for, you can choose between 4 presets for the level of detail. Choosing Low (fast) will export to an image fast but with less detail, while choosing Medium, High or Highest (slow) will produce greater detail but will take more time.

This is not available in Ray Tracing quality

8. The **Transparent Background** option allows you to set the background transparent instead of the background (color or image) defined in the Scene Settings. This is only available when outputting a TIFF or PNG



**Note:** In Ray Tracing quality, there will be no floor reflections in the image if you choose to have a transparent background.

9. Click **Export** to save the file.

If you export in **Ray Tracing** quality, a separate window will show the result as it builds up. See [Export Ray Tracing Quality Image](#) on page 177

The **Scene Settings** are used in the exported image: Object heading and Tilt, Pan, Perspective, etc. See [Scene Settings](#) on page 148



**Tip:**

If you want to use Photoshop to add some more realism to the 3D renderings, you can output two TIFFs: one with only shading and one with only graphics (all other settings identical). You can then combine them as two layers in **Multiply** mode and fine-tune the shading layer.

### 6.1.1. Export Ray Tracing Quality Image

If you export an Image or Image Sequence in **Ray Tracing** quality, a separate window will show the result as it builds up.

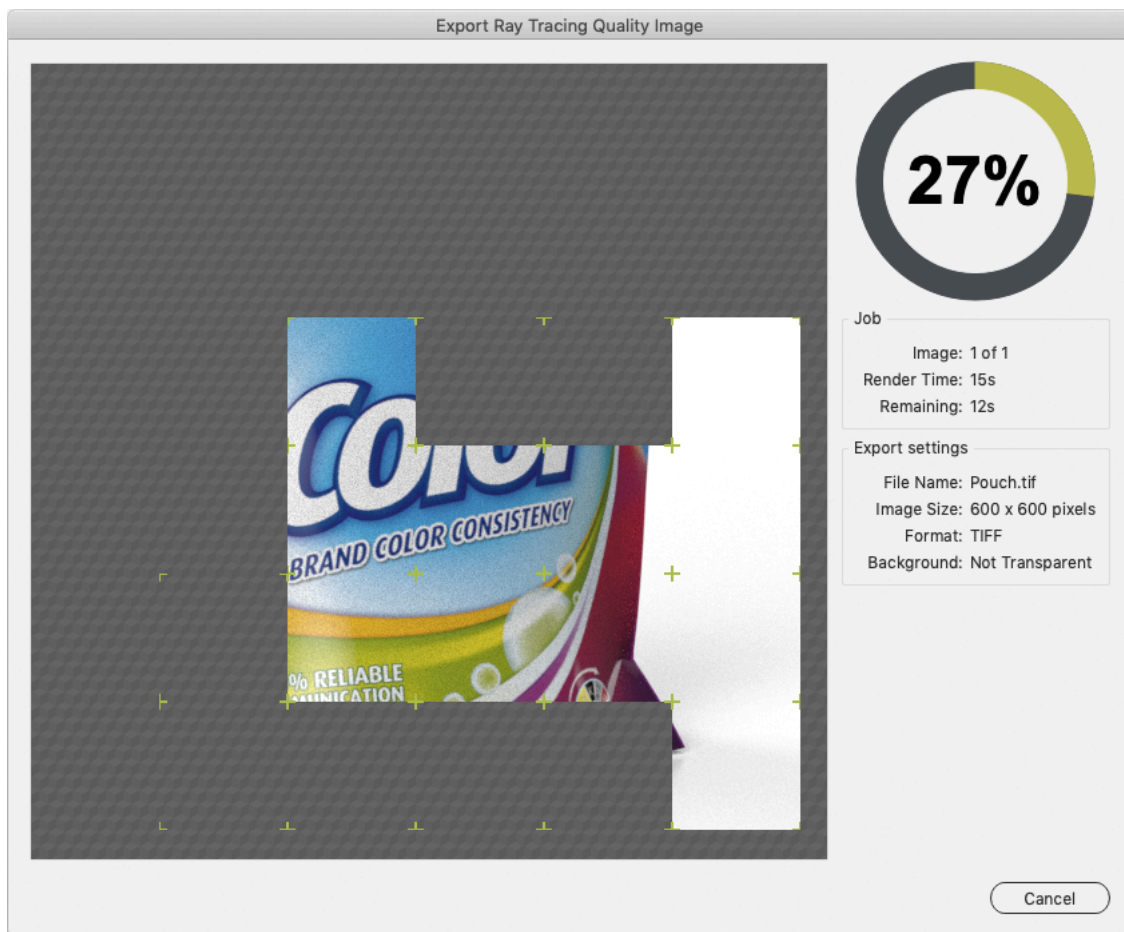

- The right side of the window shows a progress indicator, the Render Time, Time Remaining, and Export settings.
- You can click the **Cancel** button to interrupt the process.
- The preview in Ray Tracing quality shows a background pattern for areas that are not yet rendered. Transparent background from the final result will be shown as white in the preview.
- Parts of the image that are in the process of being calculated are indicated by corner marks. Intermediate steps in image rendering are also shown with corner marks to give an early indication of what the final result will look like.

## 6.2. Export Image Sequence

Studio Designer can export the 3D design to an animated sequence of JPEG, PNG or TIFF images, that can be used to create movies.

1. Choose **Export...** from Studio's fly-out menu. Choose **Image Sequence** as export type.

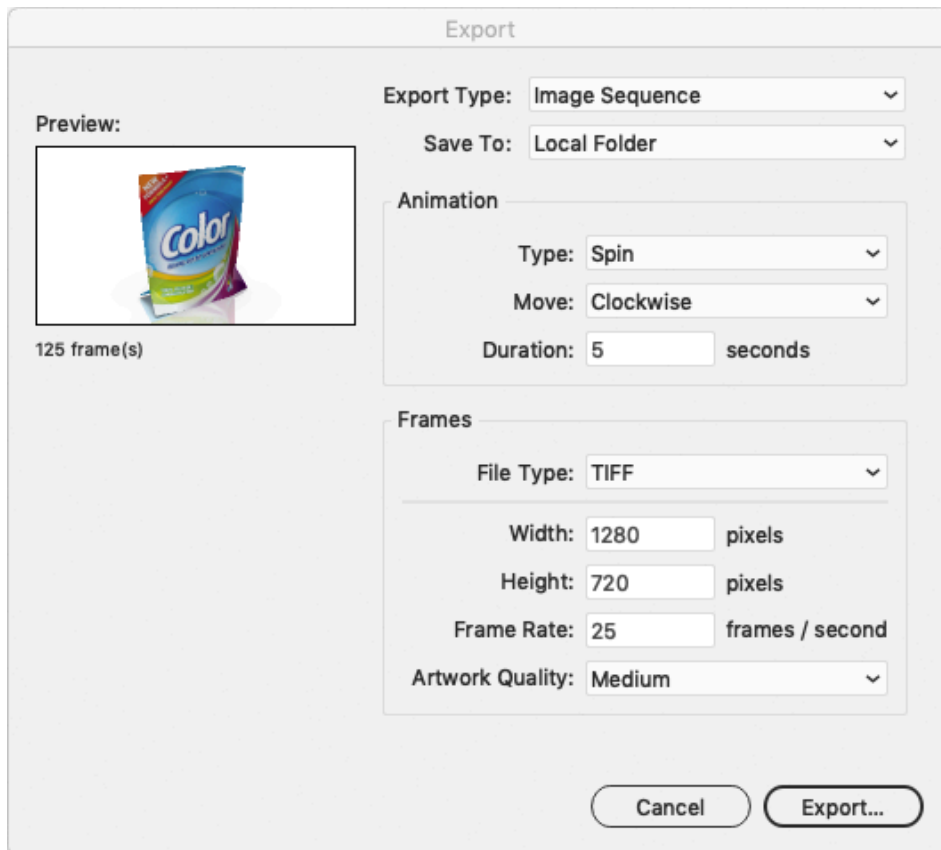

2. Set the **Animation** type and settings you want to use for the Image Sequence.
  - **Spin**: a 360 degrees rotation around the model's vertical axis. In the **Move** dropdown you can set the direction: Clockwise (CW) or Counterclockwise.
  - **Transition**: the camera animates from one view to another. In **From** and **To** you can select one of the view presets (Front, Back, Bottom, ...) or the current view.
  - **Wiggle**: the camera simultaneously rotates around the vertical and horizontal axis of the model. Use **Vertical** and **Horizontal** to set the angle of rotation.
3. Set the **File Type**: TIFF, JPEG or PNG.
4. If File Type is set to JPEG, you can set the **Quality**: Low, Medium, High or Maximum. A higher quality will result in a larger file, while lower quality will allow more compression and thus a smaller file size.
5. Set the **Duration** for the animation in seconds. The lower the value, the faster the animation will spin, transition or wiggle.
6. Set the **Width** and **Height** of the images to be created.

7. Set the **Frame Rate**: how many images should be created per second. Underneath the Preview you can see the total number of frames that will be created.
8. Define the **Artwork Quality**.  
 Choosing Low (fast) will export to an image fast but with less detail, while choosing Medium, High or Highest (slow) will produce greater detail but will take more time.  
 This is not available in Ray Tracing quality
9. Click **Export** to save the file.  
 If you export in **Ray Tracing** quality, a separate window will show the result as it builds up. See [Export Ray Tracing Quality Image](#) on page 177

### 6.2.1. Integrate an Image Sequence in an HTML5 web page

You can integrate an image sequence (exported from Studio 16.1.1 or later) in an HTML5 web page. This means that all the images are rendered upfront.

The advantage is that even complicated models can be viewed smoothly on any device, and that it is easier to integrate in other web sites. The downside is that the animation is fixed, so the user can only move the model in a preconfigured way.

The alternative is using a Studio Viewer - see [Studio Viewers](#) on page 188.

You can download an example of HTML5 web page containing an image sequence, and use your own content in it.

1. Download the ZIP file containing the example Image Sequence and HTML5 code here: [http://docs.esko.com/docs/en-us/studioessentials/18/otherdocs/HTML5\\_Image\\_Sequence\\_Viewer.zip](http://docs.esko.com/docs/en-us/studioessentials/18/otherdocs/HTML5_Image_Sequence_Viewer.zip)



**Note:** This ZIP file also contain this instructions on how to use it.

2. Prepare your scene in Studio
3. Export the Image Sequence, using this settings:
  - **File Type**: jpeg or png. TIFF is not supported on all browsers.
  - **Animation**: set Type to "Spin", and Move to "Model CCW"
  - Set the image **Width** and **Height**, and remember these values.
  - Set the **Duration** and **Frame Rate**. Remember these values, as well as the total amount of frames (shown below the preview).
  -
4. Save the images in the ImageSequence folder, using **Frame** as filename, hence overwriting the images already there.
5. Open the **index.html** file in a text or html editor. Change the following lines according to the values you used in the Export, and save the file.

```
var imageWidth = 400; // The width (in pixels) of your images
var imageHeight = 400; // The height (in pixels) of your images
var numberOfFrames = 36; // The total number of images
var framesPerSecond = 8; // How fast you want the animation to play
```

```
var framesExtension = ".tif"; // The file extension of your images.
```

6. Double-click the index.html file to check the result in your browser.

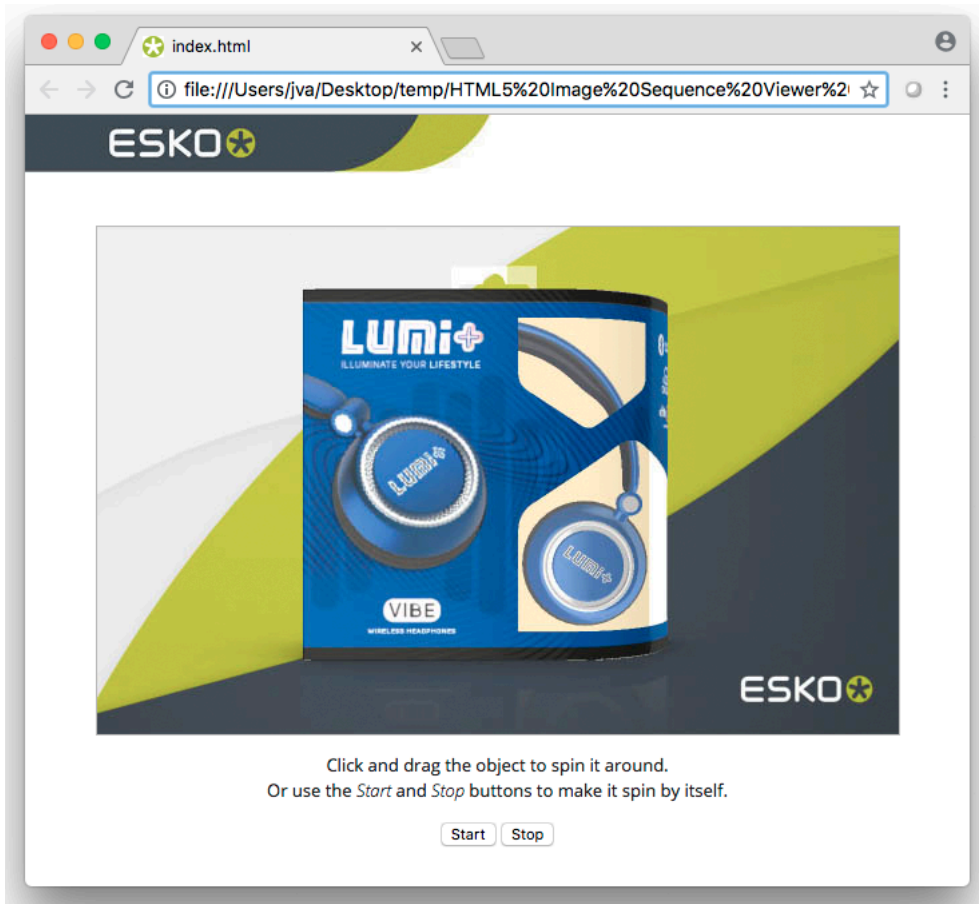

7. An experienced web developer can integrate this into a different web page.
  - a) Copy the part between `<!-- Begin 3D Viewer -->` and `<!-- End 3D Viewer -->` from the `index.html` file into the html code of your own web page.
  - b) Make sure that all the images are reachable from the local url such as "ImageSequence/Frame0.tif". If you have to put them in a different location, then you will have to adapt the `imagesequence.js` file.
  - c) Make sure the javascript code is reachable from the local url "js/imagesequence.js", or adapt the html code to load it from another location.

If the result is not what you expected:

- If you don't see anything in the html file, check if you can open a single image, and check if the file name of the first frame is "Frame00.png" or "Frame00.jpeg". You can open your browsers development console to check for error messages.
- If the animation is distorted, check the values of `ImageWidth` and `ImageHeight` in `index.html`.
- If the animation skips, check the value of `NumberOfFrames` in `index.html`. This number should be one more than the highest number in the file names in the `ImageSequence` folder.
- If the animation is slow to load, check the total size of all the images. Since these have to be loaded all to show the full animation, it's advisable to keep them below 50Mb in total. You can reduce this in different ways:
  - use **jpeg** as file type, since this typically results in smaller files



- Reduce the **Image Size**
- Lower the **Frame Rate**. This will make the animation less smooth.

## 6.3. Export Collada File

Studio Essentials can also export to a Collada file (\*.zae), a common exchange format for 3D models.



**Note:** Export Collada File is not available in Ray Tracing quality.

1. Choose **Export...** from Studio's fly-out menu.
2. Choose **Collada File** (\*.zae) as export type.

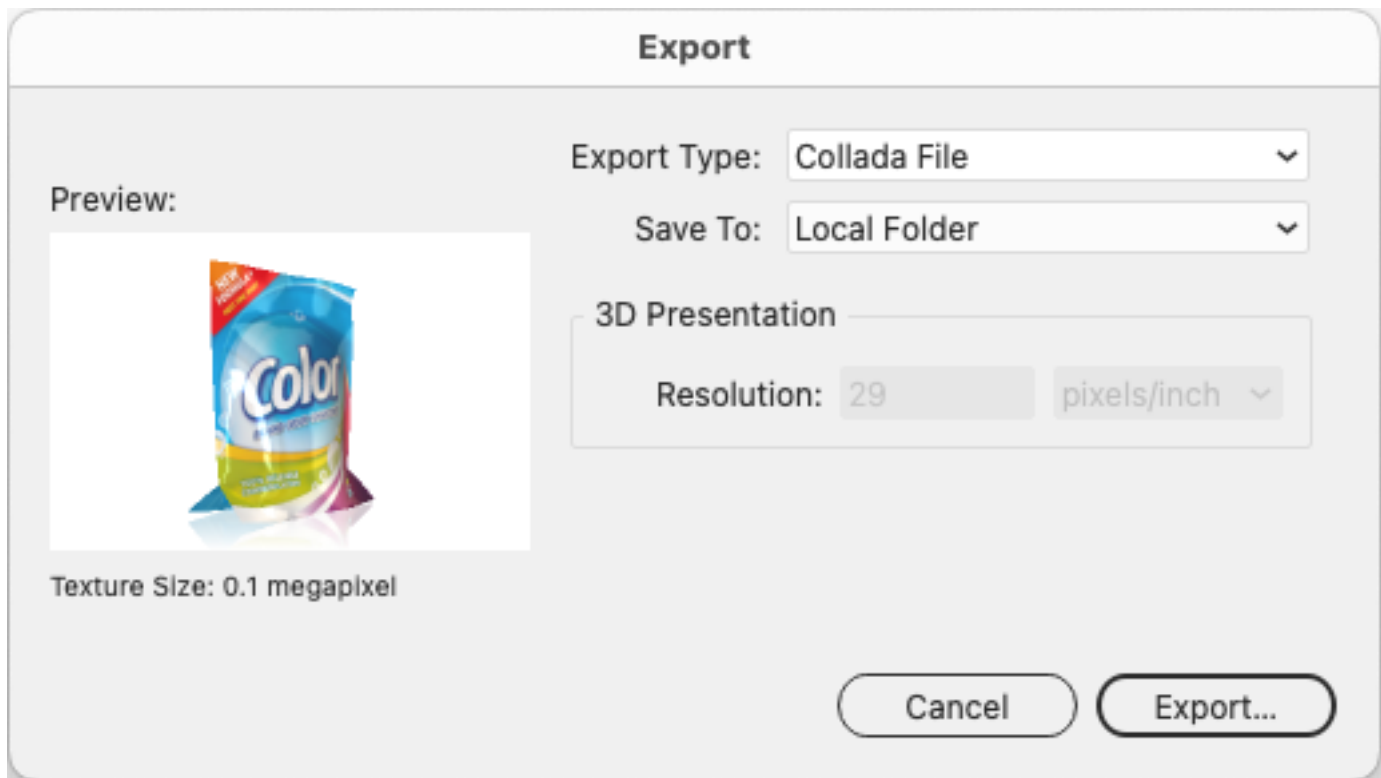

3. Define where to save the result in the **Save To:** choose Local Folder, WebCenter or Esko Cloud. See [Using Studio Designer and WebCenter Connector](#) on page 191 and [Using Studio Designer and Esko Cloud Connector](#) on page 191
4. Specify the **Resolution** for the graphics.
  - In Visualizer quality, you can't specify the resolution. The resolution is optimized so that textures within the Collada file are never larger than 2K x 2K
  - In Designer quality, you can set the resolution. If the resolution is higher than the optimal resolution, you will get a warning that the model will be sliced. If the file is intended for viewing,

the slicing will not cause any problems, but if you want to use the file in a 3D modeling program, you can choose to use the optimal resolution instead.

5. Click **Export** to save the file.



**Note:** The exported Collada files (.zae) can be further used in other Esko Studio applications such as Studio Toolkit or Esko Store Visualizer and ArtiosCAD, or can be viewed in the iOS or Android Studio Viewer app or in the standalone Studio Viewer application.



**Note:** Not all lighting environments are supported in the Studio viewers: "Photo Studio 5" and "Photo Studio 6" are replaced by "Photo Studio 2", and custom lighting environments are replaced by the "Office" environment.



**Note:**

Since Studio 23.03, Collada files will always be exported including graphics, but without printable parts. As a result, these Collada files can no longer be used as Structural Design file in Adobe Illustrator.

In earlier versions of Studio, **Export Collada File** was sometimes used to include material changes to the non-printable parts in the Collada file. In version 23.03 and above, you can use **Send Non-Printable Materials to Toolkit** for this. See [Send Non-Printable Materials to Toolkit](#) on page 121

## 6.4. Export KeyShot

Studio Designer can export the 3D design to a KeyShot file (.bip), a common exchange format for 3D models. KeyShot is a third party application with which photorealistic renders and animations can be made of the imported model.



**Note:** **Export Keyshot** is not available in Ray Tracing quality.

1. Choose **Export...** from Studio's fly-out menu. Choose **KeyShot File** as export type.

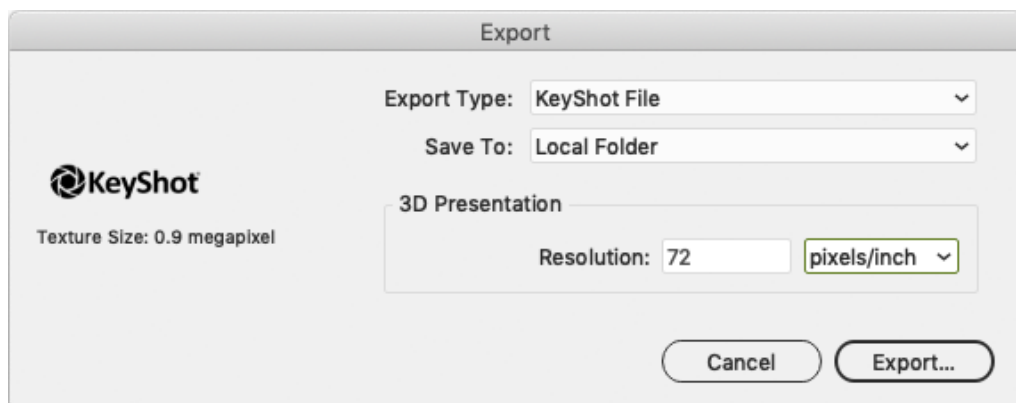

2. Specify the **Resolution** for the graphics.
3. Click **Export** to save the file.

This will save the .bip file (the structural file) and the texture folder carrying the same name next to it.

When using drag and drop to open the exported file in KeyShot®, we recommend using the **Open** option in KeyShot, and not "Import". Importing textures using the "Import" sometimes fails, resulting in black materials or unexpected quitting of the application.

Limitations:

- Holographic materials are not supported
- Changes to the panel order made by using **Bring panel forward** and **Send panel backward** are not preserved in the KeyShot file

## 6.5. Export a 3D PDF or U3D File

In Adobe Reader or Acrobat Professional (version 8.0.1 or later) you can view / rotate 3D objects in PDF files. Studio Essentials can write such PDF files that can be used to view a package in 3D on a computer that does not have Illustrator or Studio installed.

U3D is a common exchange format for 3D objects. For example, in Acrobat Professional 8.0.1 or higher you can place U3D files in PDF files.



**Note: Export a 3D PDF or U3D File** is only available in Designer quality.

1. Choose **Export...** from Studio's fly-out menu. **PDF File with 3D Design** or **U3D File** as export type.

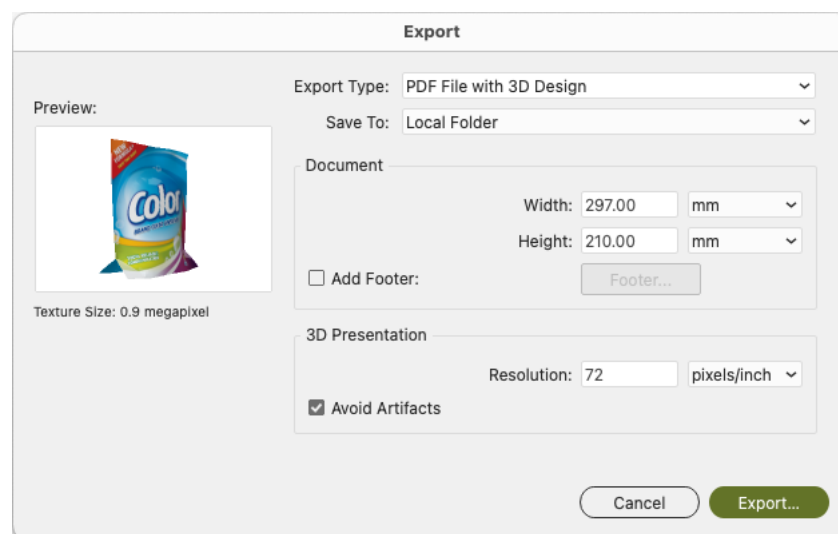

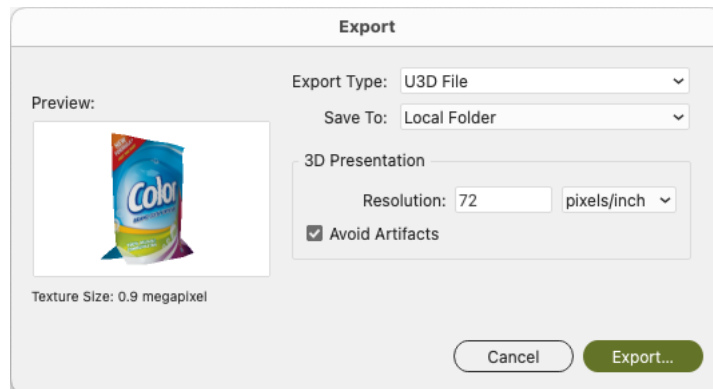

2. Define where to save the result in the **Save To**: choose Local Folder or WebCenter.  
See [Using Studio Designer and WebCenter Connector](#) on page 191
3. When exporting a PDF file, you can define the **Size** of the PDF file. Since the PDF file is only meant for on-screen viewing, this size is of little importance. The **Add Footer** toggle allows you to switch on or off the footer text. Instead of the default Esko text you can also personalize the footer text and include your own message.
4. Specify the **Resolution** for the graphics.
5. To avoid z-fighting problems in the exported PDF or U3D files, you can use the **Avoid Artefacts** option. This will make sure that whenever it is unclear which panel is on top (resulting in flickering graphics), a calculated choice will be made, cutting out the underlying part and giving the top part carte blanche.
6. Click **Export** to save the file.



## 6.6. Export a Binary glTF

glTF is a standard file format for 3D scenes and models, and can be used in various applications, e.g. Microsoft Office. Studio Essentials can write .glb files, self-contained, binary glTF files, that can be used to view a package in 3D on a computer that does not have Illustrator or Studio installed.



**Note:** Export a Binary glTF is not available in Ray Tracing quality.

1. Choose **Export...** from Studio's fly-out menu. **Binary glTF** as export type.

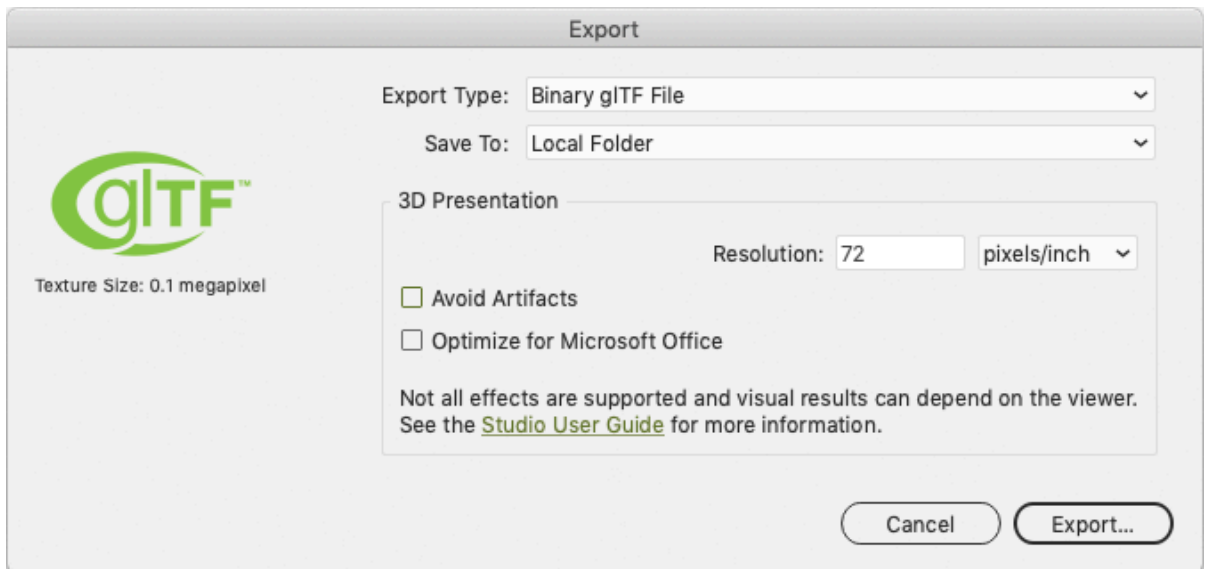

2. Specify the **Resolution** for the graphics.
  - In Visualizer quality, you can't specify the resolution. The resolution is optimized so that textures within the binary glTF file are never larger than 2K x 2K
  - In Designer quality, you can set the resolution. If the resolution is higher than the optimal resolution, you will get a warning that the model will be sliced. If the file is intended for viewing, the slicing will not cause any problems, but if you want to use the file in a 3D modeling program, you can choose to use the optimal resolution instead.
3. To avoid z-fighting problems in the exported glTF file, you can use the **Avoid Artifacts** option. This will make sure that whenever it is unclear which panel is on top (resulting in flickering graphics), a calculated choice will be made, cutting out the underlying part and giving the top part carte blanche.
4. Set the **Optimize for Microsoft Office** option.
  - When enabled, the exported glTF file will be optimized for viewing or including in Microsoft Office applications. It needs to be enabled to see transparency in Microsoft office. For printable parts with transparency, some color accuracy will be lost. Multiple Layers with transparency, die cut or invisible labels are sometimes rendered in the wrong order. A printable part is "transparent" from the moment it contains some transparency. For example, when printing an opaque ink on a transparent film, the opaque parts are also considered transparent.
  - When disabled, advanced glTF features are used that might result in more realistic looking files in some viewers.



**Note:**

In Visualizer quality, when **Optimized for Microsoft Office** is enabled, bottles where both the bottle and the label have transparency effects might show the back of the label through the front of label depending on the camera orientation.

A bottle is considered transparent when it has a see-through material, e.g.: glass, clear plastic, cloudy plastic, etc. The label is considered transparent when it has a (partially) transparent substrate (e.g. plastic film) or uses a Visualizer Finishing Operations die-cut operation.

Die cuts embedded in the Structural Design using Studio Toolkit (i.e. using the **Send Path to Toolkit** feature) can be used without problem.

5. Click **Export** to save the file.



**Note:** Non-printable materials will be exported as seen in Visualizer quality, even when exporting in Designer quality. For example when exporting a Designer quality glTF file featuring a glass bottle, the bottle will be transparent if the glTF viewer supports it.

**Limitations**

- Scene settings like Lighting Environment, Background, Floor Reflection and Floor Shadows are not stored in the binary glTF file. Also **Keep Vertical Lines Parallel** is not stored.
- The camera is stored in the file, but not all viewers honour this.
- From the Visualizer materials, Iridium and Holographic materials are not supported.
- 'Cloudy Plastic' as non-printable material is stored as Plastic in the binary glTF file.

**glTF Viewer limitations**

- All existing glTF viewers are not able to show more than one layer of transparency. So if you have a glass bottle with a liquid in it, the glTF viewer will show it as an empty glass bottle. As a workaround, try to limit the amount of transparent objects. In the example of the glass bottle filled with liquid, you can make the liquid a plastic.
- When optimizing the binary glTF for MS Office, colored transparent parts will lose their color. If the option is disabled, Studio will use an advanced glTF feature to store the color of the transparent part in the binary glTF file. Viewers that honour this advanced feature, will properly show the color filtering as intended.

**Extensions used by Esko**

Extension	Visualizer	Designer
KHR_materials_pbrSpecularGlossiness	Required	Optional for better legacy plastic
KHR_materials_transmission	Required for transparency	Optional for more realistic material
KHR_materials_specular	Required	Unused
KHR_materials_ior	Required	Unused

## 6.7. Studio Viewers

---

There are free Studio Viewers available for any device: Mac and Windows computers, iOS and Android tablets. The Studio Viewers can view any Collada file created by Esko software and can show all the print and finishing effects of the package.

### 6.7.1. Studio Viewer for Mac OS and Windows

The Studio Viewer applications for computers running Mac OS or Windows are available as free downloads from the Esko website: <https://www.esko.com/en/Support/DownloadsAndLicenses/free-software/#viewers>

The Studio Viewer is also included in the installation of Studio Essentials.

### 6.7.2. Studio Viewer for Mobile Devices

#### Studio Viewer for iOS

The Studio Viewer for Mac iOS is available from the App Store: <https://itunes.apple.com/us/app/studio-viewer/id520805739?mt=8>

The app requires iOS 6.0 or higher, and can be used on iPhone, iPad and iPod.

#### Studio Viewer for Android

The Studio Viewer for Mac iOS is available from the Google Play Store: <https://play.google.com/store/apps/details?id=com.esko.studioviewer>

The app requires Android 4.1 or higher.

#### Adding Collada files to the Studio Viewer library

To add Collada files to the Studio Viewer library, simply tap a Collada file in an email message, web page or in any other source, and select **Open in Studio Viewer**. The selected Collada file will be added to the library on your device.



**Note:** Only files exported by the Studio plugins in Adobe Illustrator are supported. Collada files exported from Studio Toolkit are not supported.

#### Removing Collada files from the Studio Viewer library

To remove Collada files from the Studio Viewer library tap the **Edit** button on the top right of the screen. To select the models to delete simply tap the model once. The selected models will be indicated with a green check mark. Next, press **Delete** in the top right corner to remove all selected models from the library.

#### Viewing Collada files in 3D

To view a Collada file in 3D simply tap the model in the library to open it.





You can interact with the model using simple gestures:

- Swipe using one finger to rotate the model
- Swipe using two fingers to pan the model
- double tap to reset the view.

### Viewing Collada files in Augmented Reality (AR)

You can view any Collada file in **Augmented Reality** mode. This allows you to view the file in a real environment, using your device's camera in combination with a specialized Esko tracker.

You can receive the tracker by email or print it directly from the app. The tracker is also available to download from the Esko website: <https://www.esko.com/en/Support/DownloadsAndLicenses/mobile-apps/>

To activate Augmented Reality, open a file from the library and tap the **AR** button. Now aim your camera at the tracker to see the file in Augmented Reality.

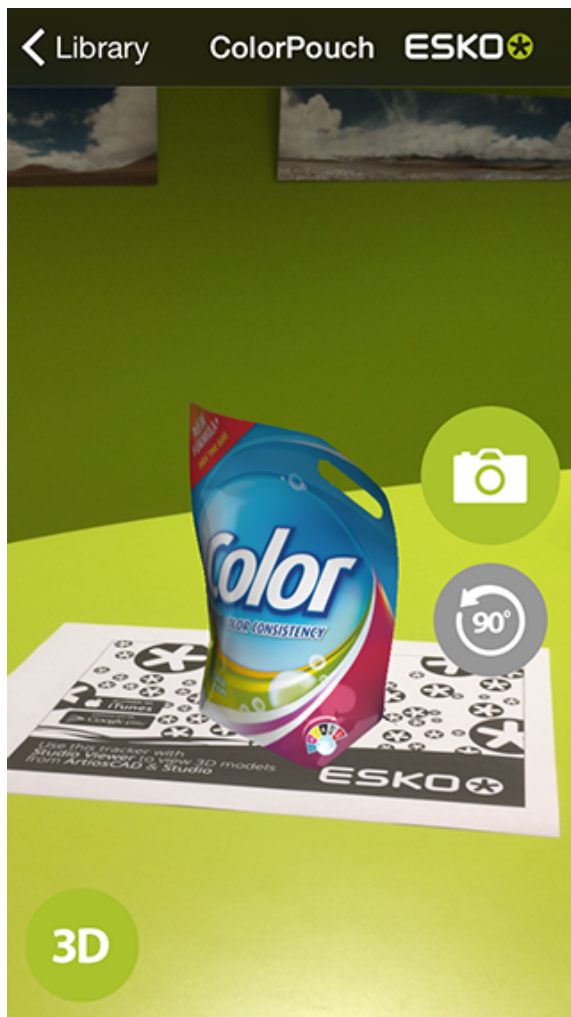

In Augmented Reality mode you can rotate the model using one finger gestures or manipulate the tracker to interact with the model. It is also possible to quickly take a photo from your design in AR by tapping the camera button.

## 7. FAQ

---

This section contains the answers to a number of Frequently Asked Questions.

### 7.1. Using Studio Designer and WebCenter Connector

---

If you have the WebCenter Connector plug-in installed, you can make a connection between WebCenter and Studio Designer.



**Note:** The WebCenter Connector plug-in needs to be installed separately. You can find it on <https://mysoftware.esko.com>

#### Load a Scene from WebCenter

If you have the WebCenter Connector plug-in installed, you can load a Scene from WebCenter

1. In the **Scene** dropdown box, select **Load Scene from WebCenter**. See also [Load Scene](#) on page 151)
2. Choose a WebCenter Server and log in using your username and password
3. Navigate to the Project containing the desired ArtiosCAD single design document or Collada file. Make sure you set the **Files of Type** selector correctly.
4. Select the file and click **Open**

WebCenter Connector will download the file, and the Scene is loaded in the Studio Designer window.



**Note:** If the loaded scene is changed in WebCenter, WebCenter Connector will inform you that a new version is available. Click **Update** to download and use the new version, or **Cancel** to continue working with the current version.

#### Export a TIFF, 3D PDF, U3D or Collada file to WebCenter

When exporting to a TIFF, 3D PDF, U3D or Collada file while having the WebCenter Connector plug-in installed, you can set the **Destination** to WebCenter.

This allows you to choose the file name, and upload the file directly to WebCenter.

See also:

- [Export Image](#) on page 175
- [Export a 3D PDF or U3D File](#) on page 183
- [Export Collada File](#) on page 181

### 7.2. Using Studio Designer and Esko Cloud Connector

---

Using the Esko Cloud Connector plug-in, you can make a connection between Esko Cloud and Studio Designer, and export Images or Collada files directly to Esko Cloud



**Note:** The Esko Cloud Connector is included in the Studio Installer. Installing Studio will automatically install Esko Cloud Connector as well.

### Export a TIFF or Collada file to Esko Cloud Connector

When exporting to a TIFF or Collada file while having the Esko Cloud Connector plug-in installed, you can set **Save To** to Share & Approve (Esko Cloud).

After clicking the **Export** button, you can enter your credentials for Esko Cloud, define the file name and location, and **Export** the file directly to Esko Cloud.

If you need to change the Esko Cloud Connector Settings, e.g. because your administrator has given you a different Base URL or you want to choose a different path for downloaded files, you can click the **Esko Cloud Settings** button in the Esko Cloud Login dialog box.

After exporting, you can click the **See in Esko Cloud** button to see your document in **Share & Approve**, where you can start sharing the document and start its approval process.

See also:

- [Export Image](#) on page 175
- [Export Collada File](#) on page 181

For more information on the Esko Cloud Connector plugin, we refer to the Esko Cloud Connector documentation: <http://www.esko.com/en/Support/Product?id=Esko%20Cloud%20Connector>

More information on Esko Cloud and Share & Approve we refer to this knowledgebase article: <https://wiki.esko.com/pages/viewpage.action?pageId=240072361>

## 7.2.1. Render Packshots on Esko Cloud

In Ray Tracing quality, rendering a Packshot can take a long time. Therefore it is possible to offload the rendering to the Esko Cloud. This allows you to continue using your computer while the Ray Tracing packshot (which is computationally intensive) is rendered on Esko Cloud.

You will be charged per Packshot. See <https://www.esko.com/en/downloads/trials/studio-cloud-rendering> to learn how to set up this service.

1. Set up the **Export Image** settings. See [Export Image](#) on page 175
2. Set the **Render On** option to **Packshots (Esko Cloud)**
3. Click **Export**
4. In the information dialog, click **Learn More** to get more information on subscriptions for offloading Packshots to Esko Cloud, or click **Continue**
5. Sign in with your **Esko ID**
6. Define the folder where the Packshot should be downloaded to after it is rendered.

The **Packshot** palette will open. You can open this palette at any time by choosing **Window > Esko > Packshots**

When a Packshot is downloaded, a thumbnail of the packshot is shown in the palette. Double-click it to open the folder where the downloaded packshot can be found.

## 7.3. I don't have Studio Essentials - where is my documentation ?

---

Studio Essentials is the combination of:

- Studio Designer
- Studio Toolkit for Boxes
- Studio Toolkit for Labels
- Studio Visualizer for Adobe Illustrator

This documentation combines the information on the individual components. If you have e.g. only Studio Toolkit for Boxes, you can still find all relevant information in this documentation. Underneath an overview of the components and a link to the most relevant chapters.

### **Studio Designer**

- [The Studio Window](#) on page 111
- [Step 2: Applying and adjusting artwork](#) on page 111
- [Step 3: Presenting](#) on page 143
- [Step 4: Share](#) on page 175

### **Studio Toolkit for Boxes**

- [Create a box](#) on page 71
- [Working with Parts and Panels](#) on page 121
- [Scenes and Multiple Documents](#) on page 151

### **Studio Toolkit for Labels**

- [Creating a revolved shape with labels](#) on page 95
- [Add a label to an existing shape](#)
- [Conical Warp](#) on page 141
- [Collada files or ACD files with Multiple Printable Parts](#) on page 154

### **Studio Toolkit for Flexibles**

- [Create a flexible bag](#)
- [Collada files or ACD files with Multiple Printable Parts](#) on page 154

### **Studio Toolkit for Shrink Sleeves**

- [Working with Shrink Sleeves](#)
- [Artwork Predistortion for Shrink Sleeves](#)

- [Scenes and Multiple Documents](#) on page 151

#### **Studio Visualizer for Adobe Illustrator**

- [Visualizer Quality](#) on page 143
- [Finishing Operations](#) on page 162

## 7.4. Scripting

---

Using the Adobe Illustrator Scripting interface, you can automate a number of Studio features using a script.

- Placing the front or back side of Structural Design files in the current Illustrator document
- Changing the alignment and rotation of a placed Structural Design
- Loading scenes
- Changing camera angles
- Applying scene presets
- Applying view presets
- Exporting to Collada
- Exporting to JPEG, PNG or TIFF Image
- Exporting to a Binary glTF file

A full reference and a sample script is available for download here: <http://docs.esko.com/docs/en-us/studioessentials/23.03/otherdocs/StudioScripting.zip>